

VARIABLE TORQUE INVERTER WITH ENERGY SAVING CONTROL

# INVERTER

# SPEECON

# 7300PA

220V Class 3 $\Phi$  5~125HP

440V Class 3 $\Phi$  5~500HP

Please hand this manual to the end-users. It will be of great help for their daily operation, maintenance, inspection and troubleshooting.

---

## BEFORE INSTALLATION & USE

1. Ensure nameplate data corresponds with your requirements.
2. Ensure the apparatus is undamaged.

## WARNING

The following safety precautions must be observed:

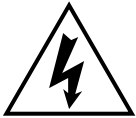

1. Electric apparatus and electricity can cause serious or fatal injury if the apparatus is improperly installed, operated or maintained. Responsible personnel must be fully trained to understand the hazards to themselves and others before being involved in installing, operating, maintaining and decommissioning electrical apparatus. European Union Safety information can be obtained from such as:

BS4999; EN60204-1    EN292-1    EN294  
IEE Wiring Regulations

Particular industries and countries have further safety requirements. Refer to their trade safety bodies, British Standards Institution, Dept. of Trade & Industry, etc., for further information. For instance, in the USA, refer to NEMA MG2, the National Electrical Code, local safety requirements, etc.

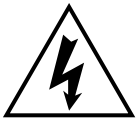

2. When servicing, all power sources to the apparatus and to the accessory devices should be de-energized and disconnected and all moving parts at standstill.
3. Safety guards and other protective devices must neither be bypassed nor rendered inoperative.



4. The apparatus must be earthed. Refer to relevant standards such as EN60204-1, IEE Wiring Regulation etc.
5. A suitable enclosure must be provided to prevent access to live parts. Extra caution should be observed around apparatus that is automatically started or has automatic resetting relays or is remotely started in case such starting means has not been properly disabled and the apparatus starts unexpectedly.

---

**CAUTION AND WARNING:**

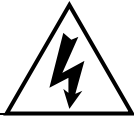

**WARNING**

- Do not change the wiring while power is applied to the circuit.
- After turning OFF the main circuit supply, do not touch circuit components until CHARGE LED is extinguished.
- Never connect power circuit output U (T1), V (T2), W (T3) to AC power supply.
- When the retry function (Cn-36) is selected, motor may restart suddenly after being stopped by momentary power loss.



**CAUTION**

- When mounting units in a separate enclosure, install a fan or other cooling device to keep the intake air temperature below 45 °C.
- Do not perform a withstand voltage test to the inverter.
- All the constants of the inverter have been factory preset. Do not change the settings unnecessarily.

---

## CONTENTS

<b>PART I INSTALLATION MANUAL</b>	<b>Pages</b>
<b>1. GENERAL</b> .....	<b>1-1</b>
1.1 SAFE OPERATION NOTES .....	1-1
1.2 PRODUCT CHANGES .....	1-1
<b>2. RECEIVING</b> .....	<b>2-1</b>
<b>3. INSTALLATION</b> .....	<b>3-1</b>
3.1 MOUNTING SPACE.....	3-1
3.2 LOCATION .....	3-2
<b>4. WIRING</b> .....	<b>4-1</b>
4.1 NOTES ON WIRING TO PERIPHERAL UNITS .....	4-1
4.2 CONNECTION DIAGRAM.....	4-2
4.3 TERMINAL FUNCTION .....	4-3
4.3.1 MAIN CIRCUIT TERMINALS .....	4-3
4.3.2 CONTROL CIRCUIT TERMINALS .....	4-3
4.3.3 MAIN CIRCUIT SCHEMATIC .....	4-4
4.4 WIRING PARTS .....	4-5
4.4.1 RECOMMENDED WIRING PARTS .....	4-5
4.4.2 CAUTIONS FOR WIRING .....	4-7
4.4.3 FUSE TYPE .....	4-9
<b>5. TEST OPERATION</b> .....	<b>5-1</b>
5.1 CHECK BEFORE TEST OPERATION.....	5-1
5.2 SETTING THE LINE VOLTAGE SELECTING CONNECTOR .....	5-1
<b>6. MAINTENANCE</b> .....	<b>6-1</b>
6.1 PERIODIC INSPECTION .....	6-1
6.2 SPARE PARTS .....	6-2
<b>7. SPECIFICATIONS</b> .....	<b>7-1</b>
<b>8. DIMENSIONS</b> .....	<b>8-1</b>
<b>9. PERIPHERAL AND OPTIONS</b> .....	<b>9-1</b>
9.1 AC REACTOR.....	9-1
9.2 NOISE FILTER .....	9-2
9.2.1 INPUT NOISE FILTER.....	9-2
9.2.2 EMI SUPPRESSION ZERO CORE .....	9-3
9.3 BRAKING RESISTOR AND BRAKING UNIT .....	9-4
9.4 OTHERS .....	9-5
9.4.1 DIGITAL OPERATOR WITH EXTENSION WIRE .....	9-5
9.4.2 ANALOG OPERATOR.....	9-6
9.4.3 LED DIGITAL OPERATOR.....	9-6
9.4.4 1 TO 8 PID RELAY CARD.....	9-6
9.4.5 RS-485 COMMUNICATION OPTION CARD .....	9-7

---

## **PART II OPERATION MANUAL**

**Pages**

<b>1. DESCRIPTION OF USING 7300PA .....</b>	<b>1-1</b>
1.1 Using LCD (OR LED) digital operator.....	1-1
1.2 DRIVE mode and PRGM mode displayed contents .....	1-3
1.3 Parameter description.....	1-4
1.4 Sample example of using LCD digital operator.....	1-5
<b>2. SETTING USER CONSTANT .....</b>	<b>2-1</b>
2.1 Frequency Command An- .....	2-1
2.2 Parameters Can Be Changed during Running Bn- .....	2-2
2.3 Control Parameters Cn- .....	2-10
2.4 System Parameters Sn- .....	2-25
2.5 Monitoring Parameters Un- .....	2-66
2.6 Monitoring Parameters Hn- .....	2-68
2.7 Order Parameters On- .....	2-70
<b>3. FAULT DISPLAY AND TROUBLE SHOOTING.....</b>	<b>3-1</b>

### **APPENDIX:**

A. ENERGY-SAVING CONTROL .....	App-1
B. PID CONTROL.....	App-3
C. RS-485 COMMUNICATION CONNECTION DIAGRAM.....	App-8
D. SINK/SOURCE TYPICAL CONNECTION DIAGRAM.....	App-10
E. RS-232C SERIAL COMMUNICATIONS CONNECTION DIAGRAM .....	App-12
F. NOTES ON APPLICATION OF MOTORS .....	App-13
G. PERIPHERAL UNIT NOTES .....	App-14
H. CIRCUIT PROTECTION AND ENVIRONMENTAL RATING NOTES.....	App-15
I. INVERTER HEAT LOSS.....	App-17
J. DRIVE INPUT FUSES.....	App-18
K.CERTIFICATION FOR THE INVERTER.....	App-19

---

## FIGURE CONTENTS

<b>FIGURE NO.</b>	<b>Pages</b>
<b>PART Installation Manual</b>	
Fig.1 Mounting Spaces.....	3-1
Fig.2 Standard Connection Diagram.....	4-2
Fig.3 Grounding of Three 7300PA Units.....	4-8
Fig.4 Shielded Wire Termination.....	4-8
Fig.5 Voltage Selecting Connector .....	5-1
Fig.6 LCD Digital Operator Dimension.....	9-5
Fig.7 Analog Operator .....	9-6
Fig.8 Option card Installation .....	9-7
<b>PART Operation Manual</b>	
Fig.9 LCD/LED Digital Operator Component names and functions.....	1-1
Fig.10 Diagram of Multi-function Analog Output.....	2-5
Fig.11 Block Diagram of PID Control Section.....	2-6
Fig.12 3-wire Sequence.....	2-48
Fig.13 Pump Operation Mode.....	2-64
Fig.14 PID Control Operations .....	App-5
Fig.15 Wiring for PA-M Modbus Protocol Communication.....	App-8
Fig.16 Wiring for Profibus Protocol Communication.....	App-9

## TABLE CONTENTS

<b>TABLE NO.</b>	<b>Pages</b>
<b>PART Installation Manual</b>	
Table1 Main Circuit Terminals.....	4-3
Table2 Control Circuit Terminals .....	4-3
Table3 220V and 440V Class Applicable Wire Size and Contactor .....	4-5
Table4 Periodic Inspection.....	6-1
Table5 Spare Parts for 220V Class .....	6-2
Table6 Spare Parts for 440V Class .....	6-3
Table7 Dimension and Weight.....	8-1
Table8 AC Reactor.....	9-1
Table9 Input Noise Filter .....	9-2
Table10 Braking Resistor and Braking Unit.....	9-4
<b>PART Operation Manual</b>	
Table11 Key's Functions .....	1-2

---

# **PART I**

# **INSTALLATION MANUAL**

# 1. GENERAL

## 1.1 SAFE OPERATION NOTES

Read this installation manual thoroughly before installation, operation, maintenance or inspection of the inverter. Only authorized personnel should be permitted to perform maintenance, inspections or parts replacement.

In this manual, notes for safe operation are classified as:

"WARNING" or "CAUTION".



: Indicates a potentially hazardous situation which, if not avoided, could result in death or serious injury to personnel.



: Indicates a potentially hazardous situation which, if not avoided, may result in minor or moderate injury to personnel and damage to equipment. It may also be used to alert against unsafe practices.

This inverter has been placed through demanding tests at the factory before shipment. After unpacking, check for the following:

1. Verify that part numbers on shipping carton and unit match the purchase order sheet and/or packing list.
2. Do not install or operate any inverter which is damaged or missing parts.
3. Do not install or operate any inverter which has no QC marking.

Contact your local distributor or TECO representative if any of the above have been found.



## 1.2 PRODUCT CHANGES

TECO reserves the right to discontinue or make modifications to the design of its products without prior notice, and holds no obligation to make modifications to products sold previously. TECO also holds no liability for losses of any kind which may result from this action.

## 2. RECEIVING

	<h3>CAUTION</h3>
<p>This 7300PA has been put through demanding tests at the factory before shipment. After unpacking, check the followings.</p> <ul style="list-style-type: none"> <li>● Verify the received product with the purchase order sheet (invoice) and/or packing list.</li> <li>● Transit damage.</li> </ul> <p>If any part of 7300PA is damaged or lost, immediately notify the shipper.</p>	

### NAMEPLATE DATA ( 220V CLASS 75HP example )

MODEL	JNTFBGBA0075JK- - -	← Inverter Model
	220V CLASS INVERTER	← Input Spec.
INPUT	AC 3PH 200-240V 50/60Hz	← Output Spec.
OUTPUT	AC 3PH 0-240V 81KVA 212A	← Series No.
SER. NO.		
  		← CE Mark & CSA Mark

### MODEL DESIGNATION

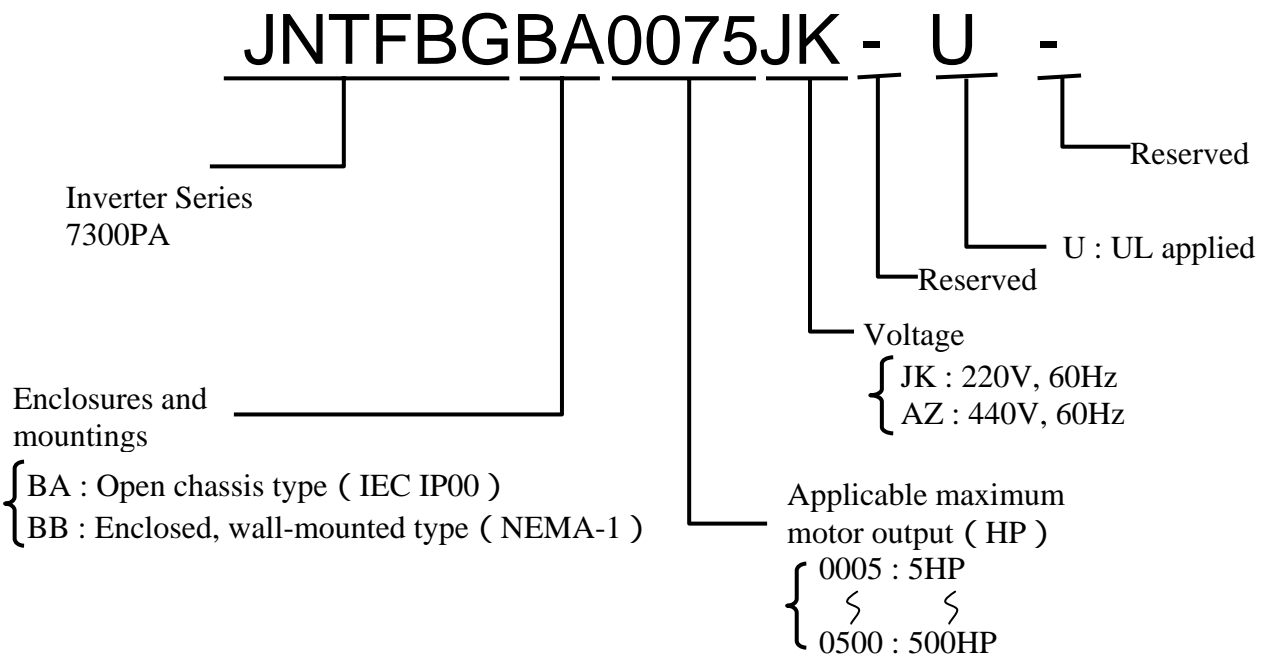

### 3. INSTALLATION



#### CAUTION

- Never move, lift or handle the 7300PA cabinet by the front cover.
- Lift the cabinet from the bottom.
- Do not drop the inverter.

#### 3.1 MOUNTING SPACE

Install 7300PA vertically and allow sufficient space for effective cooling as shown in Fig. 1.

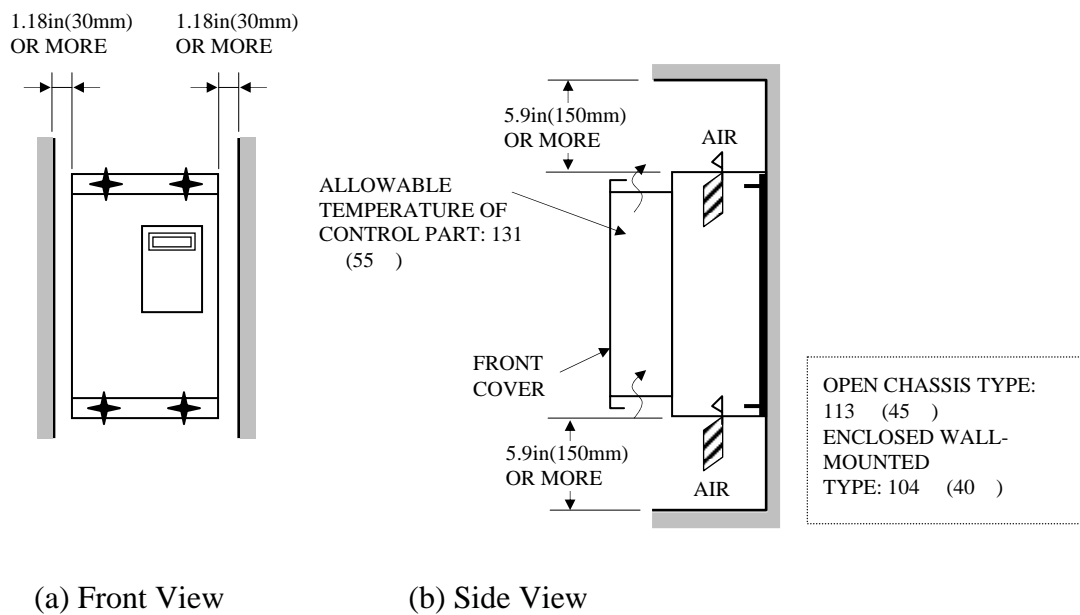

Note: For product external dimensions and mounting dimensions, refer to "DIMENSIONS" on page 8-1.

**Fig. 1 Mounting Spaces**

## 3.2 LOCATION

Location of the equipment is important to achieve proper performance and normal operating life. The 7300PA should be installed in areas where the following conditions exist:

- Protected from rain or moisture.
- Protected from direct sunlight.
- Protected from corrosive gases or liquids.
- Free from airborne dust or metallic particles.
- Free from vibration.
- Free from magnetic noise (e.g. welding machines, power units)
- Ambient temperature:
  - +14 to 104 °C, -10 to +40 °C (For enclosed type),
  - +14 to 113 °C, -10 to +45 °C (For open chassis type)
- Free from combustible materials, gases, etc.



### CAUTION

When mounting multiple units in a common enclosure, install a cooling fan or some other means to cool the air entering the inverter to at least 113 °C (45 °F) or below.

## 4. WIRING

### 4.1 NOTES ON WIRING TO PERIPHERAL UNITS

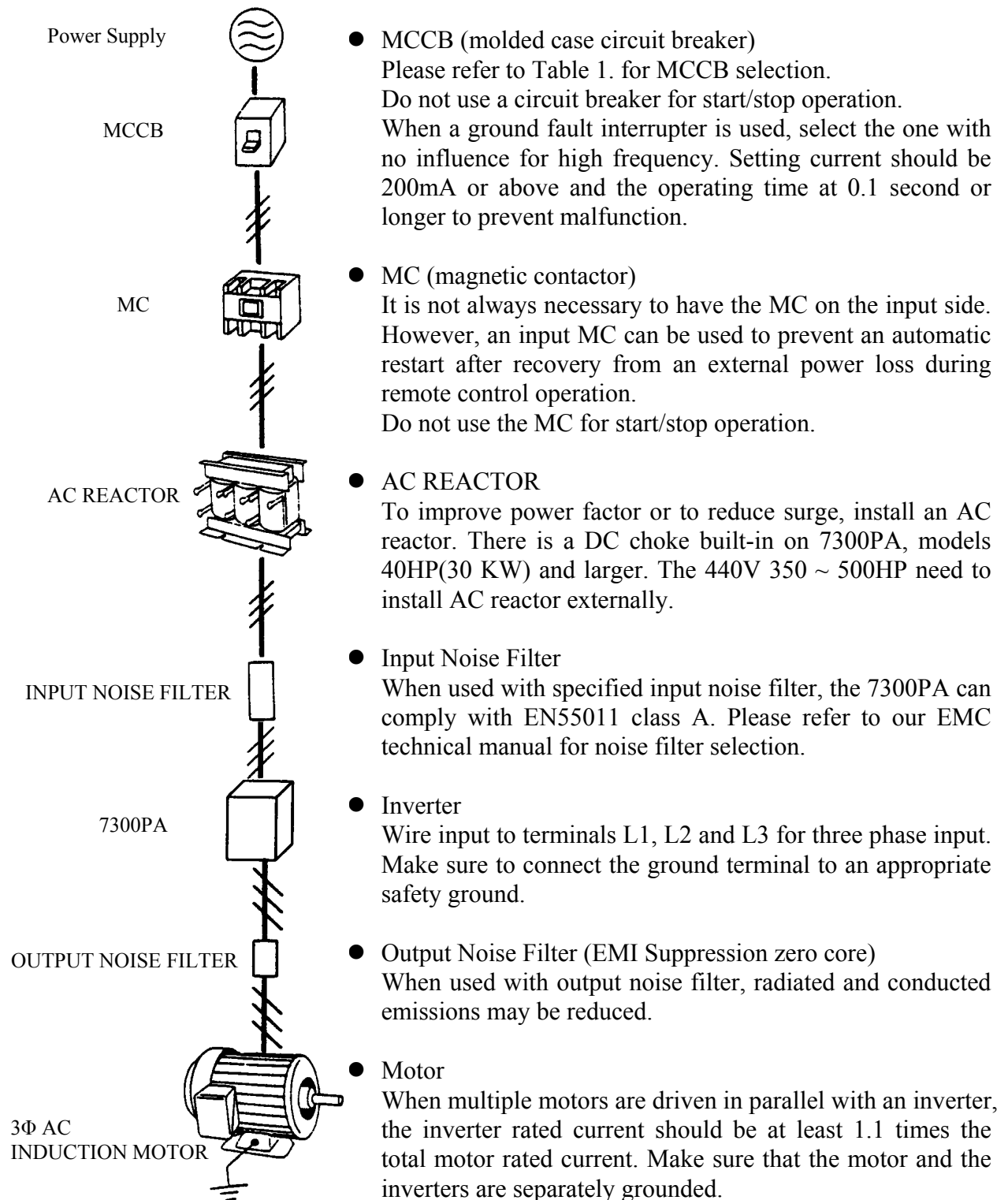

## 4.2 CONNECTION DIAGRAM

The following diagram shows interconnection of the main circuit and control circuit. With the digital operator, the motor can be operated by wiring the main circuit only. (Terminal Symbols:  $\textcircled{\ominus}$  indicates main circuit;  $\textcircled{\oplus}$  indicates control circuit).

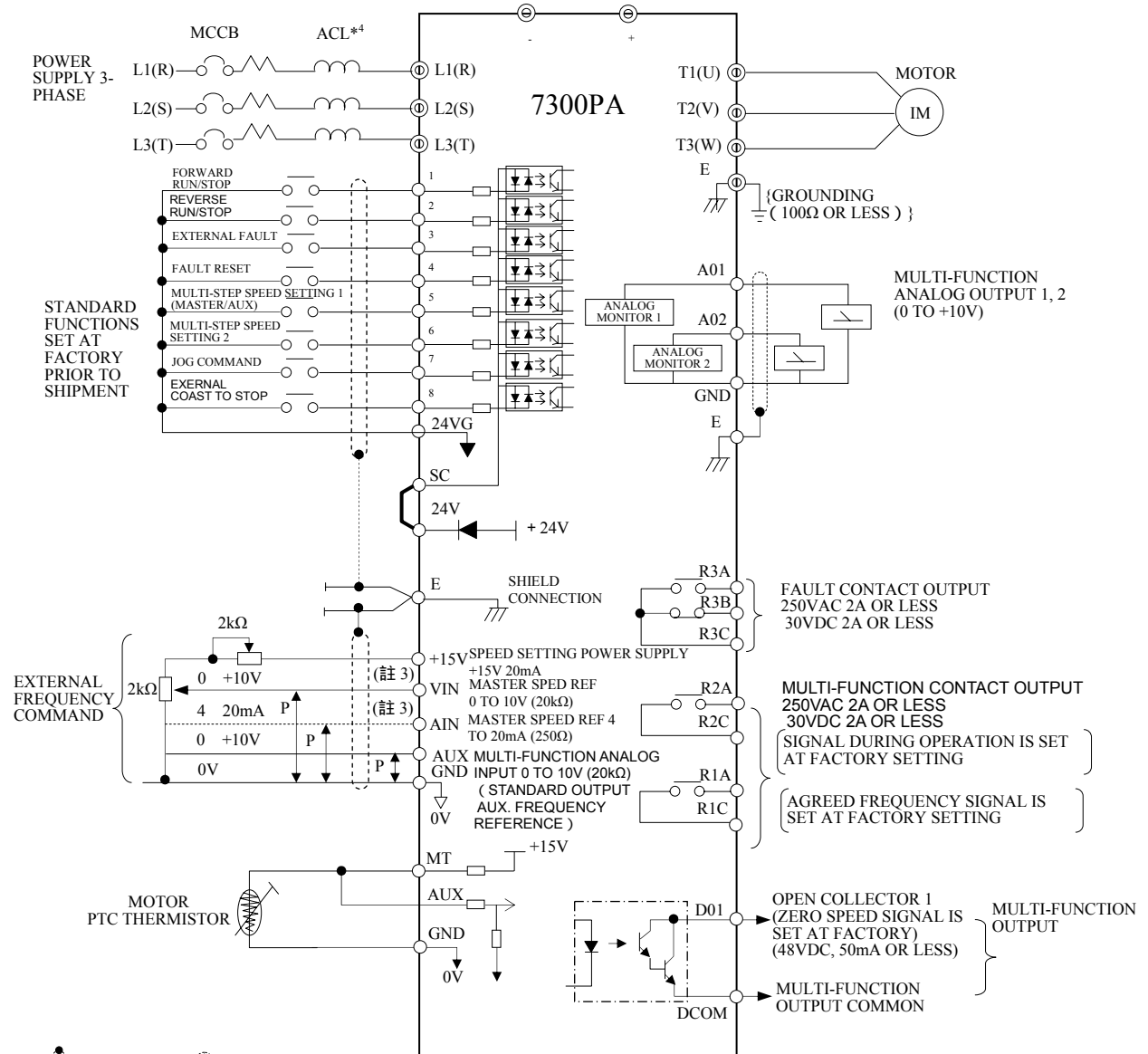

\* 1  $\textcircled{\ominus}$  shield wire  $\textcircled{\oplus}$  shield twisted wire

\* 2. The terminal 1 ~ 8 can be connected as SINK or SOURCE type input interface.  
(Ref. to Appendix D)

\* 3. The terminal arrangement.

1	2	3	4	5	6	7	8	9	10	11	12	13	14	15	16	17	18	19	20	21	22	23	24	1	2	3	4	5	6	7
24VG	24VG	1	2	3	4	5	6	7	8	SC	24V	E	15V	VIN	AIN	AUX	MT	GND	A01	A02	GND	D01	DCOM	R1A	R1C	R2A	R2C	R3A	R3B	R3C

\* Shorted at factory

\* For 440V 350HP ~ 500HP need to install ACL externally.

**Fig. 2 Standard connection diagram.**

## 4.3 TERMINAL FUNCTION

### 4.3.1 MAIN CIRCUIT TERMINALS

**Table 1. Main Circuit Terminals**

Terminals	Terminal Function
R / L1	Main Circuit Input Power Supply
S / L2	
T / L3	
U / T1	Inverter Output
V / T2	
W / T3	
+	DC Power Supply Input or Braking Unit
-	
B2	B2 - + : External Braking Resistor (Only for 220V 25HP, 440V 25HP, 30HP)
E ( PE, $\perp$ )	Grounding (3rd Type Grounding)

### 4.3.2 CONTROL CIRCUIT TERMINALS

**Table 2. Control Circuit Terminals**

I/O	Terminal	Functions	
Digital Input Terminals	1	Forward operation-stop signal.	
	2	Reverse operation-stop signal.	
	3	External fault input.	
	4	Fault reset.	
	5	Multi-function contact input: the following signals available to select. Forward/reverse select, run mode select, multi-speed select, jog frequency select, accel/decel time select, external fault, external coast to stop, hold command, inverter overheat prediction, DB command, aux. Input effective, speed search, energy-saving operation.	
	6		
	7		
	8		
		24VG	SINK Common (0V), ref to appendix D.
		24V	SOURCE Common (24V), ref to appendix D.
	SC	Sequence input Common (24V), ref to appendix D.	
Analog Input Terminals	+15V	+15V power supply for external frequency command.	
	VIN	Master speed voltage reference (0 to 10V).	
	AIN	Master speed current reference (4 to 20mA).	
	AUX	Auxiliary analog command: one of the following signals available to select. Frequency command, frequency gain, frequency bias, overtorque detection level, voltage bias, accel/decel rate, DB current.	
	MT	Motor temperature PTC thermistor. (active: 1330Ω, Return: 550Ω)	
	GND	Analog signal common.	
	E	Connection to shield signal lead. (frame ground)	
Digital Output Terminals	R3A	Fault contact output A (Closed at fault).	
	R3B	Fault contact output B (Open at fault).	
	R3C	Fault contact output common.	
	R2A-R2C	Multi-function contact output: one of the following signals available to output. Output during running, zero speed, synchronized speed, arbitrary speed agreed, frequency detection, overtorque, undervoltage, run mode, coast to stop, braking resistor overheat, alarm, fault.	
	R1A-R1C		
	D01	Multi-function PHC (photo-coupler) output 1 (open collector, 48VDC, 50mA)	The same functions as terminals R1A-R1C and R2A-R2C
DCOM	Multi-function PHC output common.		
Analog Output Terminals	A01	Analog multifunction output port: Frequency command, Output frequency, Output current, Output voltage, DC voltage, Output power.	0~11V max. 2mA or less
	A02		
	GND	Common lead for analog port.	

### 4.3.3 MAIN CIRCUIT SCHEMATIC

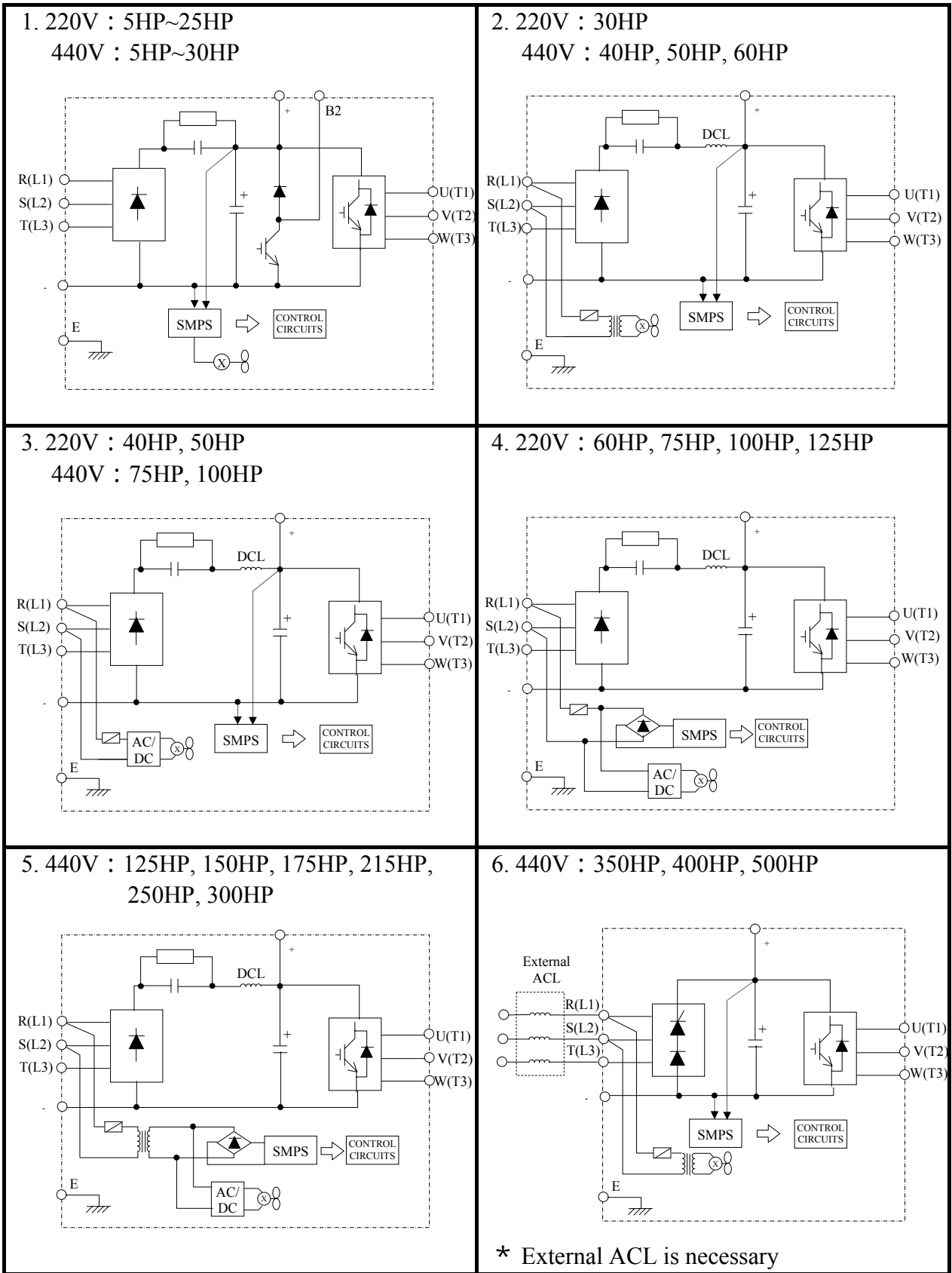

## 4.4 WIRING PARTS

### 4.4.1 RECOMMENDED WIRING PARTS

Be sure to connect MCCBs between power supply and 7300PA input terminals L1 (R), L2 (S), L3 (T). Recommended MCCBs are listed in Table 3.

When a ground fault interrupter is used, select the one with no influence for high frequency. The current setting should be 200mA or over and operating time, 0.1 second or over to prevent malfunction.

**Table 3. 220V and 440V class applicable wire size and contactor**

(a) 220V SERIES

Max. Applicable Motor Output HP (KW) [Note 1]	Cable Size - mm <sup>2</sup> (AWG)			Molded-Case Circuit Breaker [Note 4]	Magnetic Contactor [Note 4]
	Power Cable [Note 2]	Ground Cable E [G]	Control Cable [Note 3]		
5(3.7)	5.5	5.5	0.5 2	TO-50EC (30A)	CN-16
7.5(5)	8	5.5~8	0.5 2	TO-100S (50A)	CN-18
10(7.5)	8	5.5~8	0.5 2	TO-100S (60A)	CN-25
15(11)	22	8	0.5 2	TO-100S (100A)	CN-50
20(15)	22	8	0.5 2	TO-100S (100A)	CN-65
25(18.5)	22 (4)	14 (6)	0.5 2 (20-14)	TO-225S (150A)	CN-80
30(22)	22 (4)	14 (6)	0.5 2 (20-14)	TO-225S (175A)	CN-100
40(30)	60 (2/0)	22 (4)	0.5 2 (20-14)	TO-225S (175A)	CN-125
50(37)	60 (2/0)	22 (4)	0.5 2 (20-14)	TO-225S (200A)	CN-150
60(45)	60×2P (2/0×2P)	22 (4)	0.5 2 (20-14)	TO-225S (225A)	CN-180
75(55)	60×2P (2/0×2P)	30 (2)	0.5 2 (20-14)	TO-400S (300A)	CN-300
100(75)	100×2P (4/0×2P)	50 (1/0)	0.5 2 (20-14)	TO-400S (400A)	CN-300
125(90)	100×2P (4/0×2P)	50 (1/0)	0.5 2 (20-14)	TO-400S (400A)	S-K400 【Note 5】

【Note】 1. For Constant Torque Load.

- Power Cable Include Cables to the Terminals R (L1), S (L2), T (L3), + , - , B2, U (T1), V (T2), W (T3).
- Control Cable Include Cables to the Control Terminals.
- The Molded-Case Circuit Breaker and Magnetic Contactors Shown in Table3 are Teco Products and are for reference only. Other manufactures' equivalent products may be selected.
- The Magnetic contactors S-K400 and S-K600 are Mitsubishi Products and are for reference only. Other manufactures' equivalent products may be selected.

## (b) 440V SERIES

Max. Applicable Motor Output HP (KW) [Note 1]	Cable Size - mm <sup>2</sup> (AWG)			Molded-Case Circuit Breaker [Note 4]	Magnetic Contactor [Note 4]
	Power Cable [Note 2]	Ground Cable E [G]	Control Cable [Note 3]		
5(3.7)	2~5.5	3.5~5.5	0.5 2	TO-50EC (15A)	CN-18
7.5(5)	3~5.5	3.5~5.5	0.5 2	TO-50EC (20A)	CN-18
10(7.5)	5.5	5.5	0.5 2	TO-50EC (30A)	CN-25
15(11)	8	8	0.5 2	TO-50EC (30A)	CN-25
20(15)	8	8	0.5 2	TO-100S (50A)	CN-35
25(18.5)	8 (8)	8 (8)	0.5 2 (20-14)	TO-100S (75A)	C-50L
30(22)	8 (8)	8 (8)	0.5 2 (20-14)	TO-100S (100A)	C-50L
40(30)	14 (6)	8 (8)	0.5 2 (20-14)	TO-100S (100A)	C-65L
50(37)	22 (4)	14 (6)	0.5 2 (20-14)	TO-125S (125A)	C-80L
60(45)	22 (4)	14 (6)	0.5 2 (20-14)	TO-225S (175A)	C-100L (170A)
75(55)	38 (1)	22 (4)	0.5 2 (20-14)	TO-225S (175A)	C-125G (170A)
100(75)	60 (2/0)	22 (4)	0.5 2 (20-14)	TO-225S (225A)	C-150G (200A)
125(90)	60×2P (2/0×2P)	30 (2)	0.5 2 (20-14)	TO-400S (300A)	C-300L (400A)
150(110)	60×2P (2/0×2P)	30 (2)	0.5 2 (20-14)	TO-400S (300A)	C-300L (400A)
175(125)	60×2P (2/0×2P)	50 (1/0)	0.5 2 (20-14)	TO-400S (400A)	C-300L (400A)
215(160)	100×2P (4/0×2P)	50 (1/0)	0.5 2 (20-14)	TO-400S (400A)	C-300L (400A)
250(185)	100×2P (4/0×2P)	50 (1/0)	0.5 2 (20-14)	TO-600S (600A)	S-K400 [Note 5] (450A)
300(220)	100×2P (4/0×2P)	60 (2/0)	0.5 2 (20-14)	TO-800S (800A)	S-K600 (800A)
350(270)	325×2P (650×2P)	60 (2/0)	0.5 2 (20-14)	TE-1000 (1000A)	S-K600 (800A)
400(300)	325×2P (650×2P)	60 (2/0)	0.5 2 (20-14)	TE-1000 (1000A)	S-K600 (800A)
500(375)	325×2P (650×2P)	60 (2/0)	0.5 2 (20-14)	TE-1000 (1000A)	S-K800 (1000A)

#### 4.4.2 CAUTIONS FOR WIRING



### CAUTION

The external interconnection wiring must be performed with the following procedures.

After completing 7300PA interconnections, be sure to check that connections are correct.  
Never use control circuit buzzer check.

#### (A) MAIN CIRCUIT INPUT/OUTPUT

- (1) Phase rotation of input terminals L1 (R), L2 (S), L3 (T) is available in either direction. (Clockwise and counterclockwise).
- (2) When inverter output terminals T1 (U), T2 (V), and T3 (W) are connected to motor terminals T1 (U), T2 (V), and T3 (W), respectively, motor rotates counterclockwise. (Viewed from opposite side of drive end, upon forward operation command). To reverse the rotation interchange any two of the motor leads.
- (3) Never connect AC main circuit power supply to output terminals T1 (U), T2 (V), and T3 (W). This may cause damage to the inverter.
- (4) Care should be taken to prevent contact of wiring leads with 7300PA cabinet. If this occurs, a short-circuit may result.
- (5) Never connect power factor correction capacitors or noise filters to 7300PA output.
- (6) Never open or close contactors in the output circuit unless inverter is properly sized.
- (7) The main circuit wiring need use suitable O-type terminal, and the width of terminal must be less than terminal block to insure the safety distance is enough.



### CAUTION

- Lead size should be determined taking into account voltage drop of leads. Voltage drop can be obtained by the following equation: select such lead size that voltage drop will be within 2% of normal rated voltage.

phase-to-phase voltage drop (V)

$$= \sqrt{3} \times \text{lead resistance } (\Omega / \text{km}) \times \text{wiring distance(m)} \times \text{current(A)} \times 10^{-3} .$$

- Wiring length between inverter and motor.

If total wiring distance between inverter and motor is excessively long and inverter carrier frequency (main transistor switching frequency) is high, harmonic leakage current from the cable will increase to effect the inverter unit or peripheral devices. If the wiring distance between inverter and motor is long, reduce the inverter carrier frequency.

## (B) GROUNDING (PE: Protective Earth)

Ground the 7300PA through ground terminal E (PE).

- (1) Ground resistance should be 100 ohms or less.
- (2) Never ground 7300PA in common with welding machines, motors, and other large-current electrical equipment, or ground pole. Run the ground lead in separate conduit from leads for large-current electrical equipment.
- (3) Use the ground leads which comply with AWG standards and make the sure the length is as short as possible.
- (4) Where several 7300PA units are used side by side, it is preferable to ground each unit separately to ground poles. However, connecting all the ground terminals of 7300PA in parallel while grounding only one of the 7300PA's to the ground pole is also permissible (Fig. 3). Be sure not to form a loop with the ground leads.

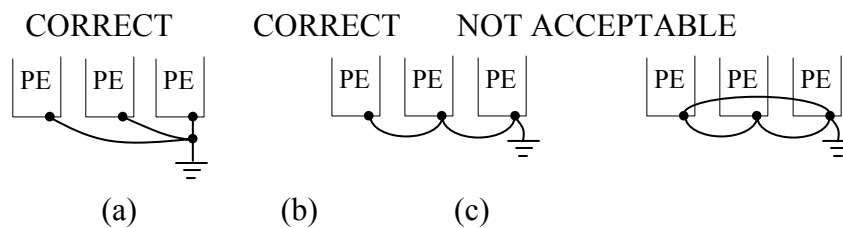

**Fig. 3 Grounding of Three 7300PA Units**

## (C) CONTROL CIRCUIT

- (1) Separation of control circuit leads and main circuit leads: All signal leads must be separated from main circuit leads L1 (R), L2 (S), L3 (T), +, -, B2, T1 (U), T2 (V), T3 (W) and other power cables to prevent erroneous operation caused by noise interference.
- (2) Control circuit leads R1A-R1B-R1C, R2A-R2C, R3A-R3C (contact output) must be separated from leads 1 to 8, A01, A02, D01-DCOM and 24V, SC, 24VG, VIN, AIN, AUX, MT, GND.
- (3) Use twisted shielded or twisted pair shielded wire for the control circuit line and connect the shield sheath to the inverter terminal E to prevent malfunction caused by noise. See Fig.4. Wiring distance should be less than 164ft (50m).

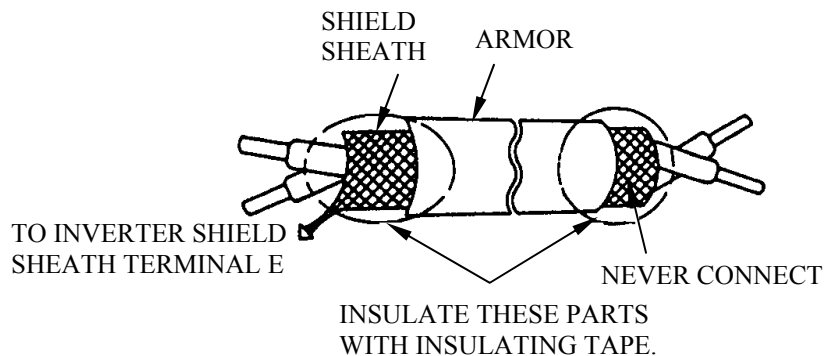

**Fig. 4 Shielded Wire Termination**

### 4.4.3 Fuse types

#### 220V class

MODEL	HP	KVA	100% CONT. Output AMPS	Rated Input AMPS	FUSE Rating
JNTFBG 0025JK	25	27.4	72	86	125
JNTFBG 0030JK	30	33	88	97	125
JNTFBG 0040JK	40	44	117	129	175
JNTFBG 0050JK	50	55	144	158	200
JNTFBG 0060JK	60	63	167	184	250
JNTFBG 0075JK	75	81	212	233	300
JNTFBG 0100JK	100	110	288	317	400
JNTFBG 0125JK	125	125	327	360	500

#### 440V class

MODEL	HP	KVA	100% CONT. Output AMPS	Rated Input AMPS	FUSE Rating
JNTFBG 0025AZ	25	29	38	46	70
JNTFBG 0030AZ	30	34	44	48	70
JNTFBG 0040AZ	40	45	59	65	100
JNTFBG 0050AZ	50	57	75	83	125
JNTFBG 0060AZ	60	66	86	95	150
JNTFBG 0075AZ	75	85	111	122	200
JNTFBG 0100AZ	100	115	151	166	250
JNTFBG 0125AZ	125	144	189	208	300
JNTFBG 0150AZ	150	176	231	254	350
JNTFBG 0175AZ	175	203	267	294	400
JNTFBG 0215AZ	215	232	304	334	450
JNTFBG 0250AZ	250	259	340	374	500
JNTFBG 0300AZ	300	290	380	418	600
JNTFBG 0350AZ	350	393	516	568	700
JNTFBG 0400AZ	400	446	585	644	800
JNTFBG 0500AZ	500	558	732	805	1000

Fuse Type UL designated SEMICONDUCTOR PROTECTION FUSES

Class CC,J,T,RK1 or RK5

Voltage Range: 300V for drives with 220V class VFD

500V for drives with 440V class VFD

## 5. TEST OPERATION

To assure safety, prior to test operation, disconnect the coupling or belt which connects the motor with the machine so that motor operation is isolated. If an operation must be performed while the motor is directly connected to the machine, use great care to avoid any possible hazardous condition.

### 5.1 CHECK BEFORE TEST OPERATION

After completion of installation and wiring, check for

- (1) proper wiring
- (2) short-circuit due to wire clippings
- (3) loose screw-type terminals
- (4) proper load

### 5.2 SETTING THE LINE VOLTAGE SELECTING CONNECTOR FOR 460V CLASS 40HP (30kW) AND ABOVE

The cooling fan line voltage selecting connector shown in Fig. 5 must be set according to the type of main circuit power supply. Insert the connector at the position showing the appropriate line voltage.

The unit is preset at the factory to 440 line voltage.

(a) 440V CLASS: 40HP ~ 100HP

350HP ~ 500HP

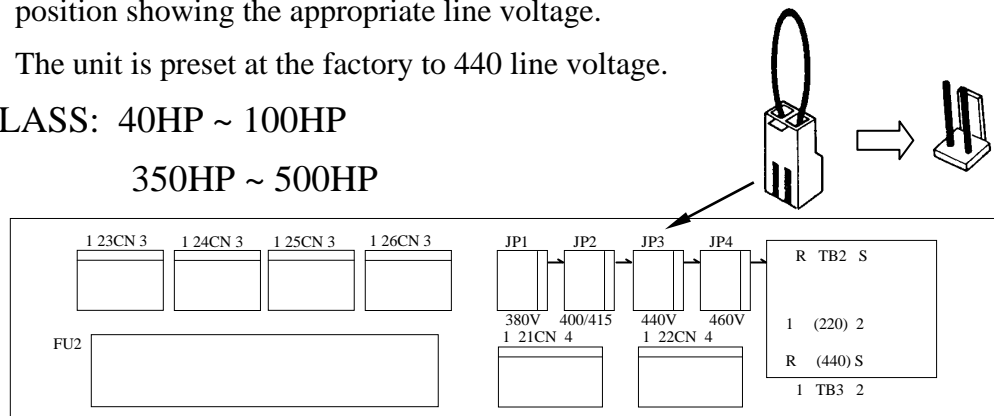

(b) 440V CLASS: 125HP ~ 300HP

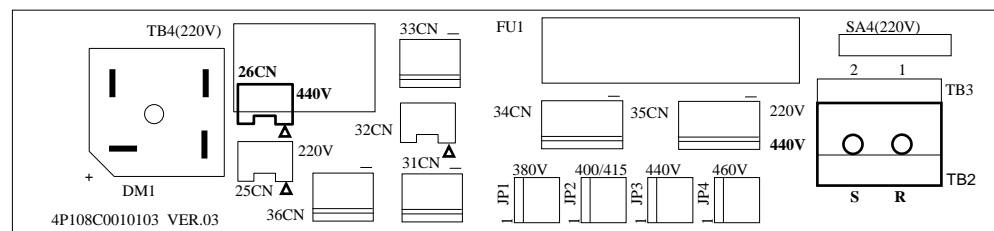

Fig. 5 Voltage Selecting Connector

## 6. MAINTENANCE

### 6.1 PERIODIC INSPECTION

The 7300PA requires very few routine checks. It will function longer if it is kept clean, cool and dry. Observe precautions listed in "Location". Check for tightness of electrical connections, discoloration or other signs of overheating. Use Table 4 as your inspection guide. Before servicing, turn OFF AC main circuit power and be sure that CHARGE lamp is OFF.

Table 4 Periodic Inspection

Component	Check	Corrective Action
External terminals, unit mounting bolts, connectors, etc.	Loose screws	Tighten
	Loose connectors	Tighten
Cooling fins	Build-up of dust and dirt	Blow with dry compressed air of $39.2 \times 10^4$ to $58.8 \times 10^4$ Pa (57 to 85psi.) pressure.
Printed circuit board	Accumulation of conductive dust or oil	Blow with dry compressed air of $39.2 \times 10^4$ to $58.8 \times 10^4$ Pa (57 to 85psi.) pressure. If dust and oil cannot be removed, replace the board.
Cooling fan	Abnormal noise and vibration. Whether the cumulative operation time exceeds 20,000 hours or not.	Replace the cooling fan.
Power elements	Accumulation of dust and dirt	Blow with dry compressed air of $39.2 \times 10^4$ to $58.8 \times 10^4$ Pa (57 to 85psi) pressure.
Smoothing capacitor	Discoloration or odor	Replace the capacitor or inverter unit.

Note: Operating conditions as follows:

- Ambient temperature: Yearly average 30 , 86
- Load factor: 80% or less
- Operating time: 12 hours or less per day

#### Standard Parts Replacement

Item Name	Replacement Cycle	Remarks
Cooling fan	2 or 3 years	Replace with a new product.
Smoothing capacitor	5 years	Replace with a new product. (Determine after examination).
Circuit Breakers and relays	-	Determine after examination.
Fuse	10 years	Replace with a new product.
Aluminum capacitor on PC board	5 years	Replace with a new product. (Determine after examination).

Note: Operating conditions as follows:

- Ambient temperature: Yearly average 30 , 86
- Load factor: 80% or less
- Operating time: 20 hours or less per day

## 6.2 SPARE PARTS

As insurance against costly downtime, it is strongly recommended that renewal parts be kept on hand in accordance with the table below. When ordering renewal parts, please specify to your local distributor or TECO representative the following information: Part Name, Part Code No. and Quantity.

Table 5 Spare Parts for 220V Class

INVERTER & PART NAME		Control PC Board*	Power Board	Main Circuit Transistor	Main Circuit Diode	Cooling Fan	
HP	SPEC						
5	MODEL	-	-	7MBR15SA140	-	AFB0824SH	
	CODE	3K3Z2079	3K3Z2113	3K3A2834	-	4H300D0200000	
	Qty	1	1	1	-	1	
7.5	MODEL	-	-	7MBR25SA140	-	AFB0824SH	
	CODE	3K3Z2079	3K3Z2114	3K3A2835	-	4H300D0200000	
	Qty	1	1	1	-	1	
10	MODEL	-	-	7MBR25SA140	-	AFB0824SH	
	CODE	3K3Z2079	3K3Z2114	3K3A2835	-	4H300D0200000	
	Qty	1	1	1	-	1	
15	MODEL	-	-	7MBR35SB140	-	AFB0824EHE	
	CODE	3K3Z2079	3K3Z2075	3K3A2836	-	4H300D5590001	
	Qty	1	1	1	-	2	
20	MODEL	-	-	7MBR50SB140	-	AFB0824EHE	
	CODE	3K3Z2079	3K3Z2116	3K3A2837	-	4H300D5590001	
	Qty	1	1	1	-	2	
25	MODEL	-	-	7MBR50SB140	-	AFB0824EHE	
	CODE	3K3Z2079	3K3Z2116	3K3A2837	-	4H300D5590001	
	Qty	1	1	1	-	2	
30	MODEL	-	-	2MBI100PC_140	DF75LA160	A2123-HBT	
	CODE	3K3Z2079	3K3Z2076	3K3A2839	277192195	4M903D1890001	
	Qty	1	1	3	1	2	
40	MODEL	-	-	2MBI100PC_140	DF75LA160	A2123-HBT	
	CODE	3K3Z2079	3K3Z2076	3K3A2839	277192195	4M903D1890001	
	Qty	1	1	3	1	2	
50	MODEL	-	-	2MBI150PC_140	DF100LA160	A2123-HBT	
	CODE	3K3Z2079	3K3Z2117	3K3A2840	277192217	4M903D1890001	
	Qty	1	1	3	1	2	
60	MODEL	-	-	2MBI150PC_140	DF100LA160	A2123-HBT	
	CODE	3K3Z2079	3K3Z2117	3K3A2840	277192217	4M903D1890001	
	Qty	1	1	3	1	2	
75	MODEL	-	-	2MBI200PB_140	2U/DDB6U145N16L	A2123-HBT	
	CODE	3K3Z2079	3K3Z2117	3K3A2841	277190222	4M903D1890001	
	Qty	1	1	3	1	2	
100	MODEL	-	-	2MBI300P_140	2U/DDB6U145N16L	A2123-HBT	
	CODE	3K3Z2079	3K3Z2118	3K3A2842	277190222	4M903D1890001	
	Qty	1	1	3	1	2	

Table 6 Spare Parts for 440V Class

INVERTER & PART NAME		Control PC Board*	Power Board	Main Circuit Transistor	Main Circuit Diode	Cooling Fan	
HP	SPEC						
5	MODEL	-	-	7MBP25RA120	7MBP25RA120	-	
	CODE	4P101C0070008	4P106C03800A1	277831716	277831716	-	
	Qty	1	1	1	1	-	
7.5	MODEL	-	-	7MBP25RA120	6RI30G-160	AFB0824SH	
	CODE	4P101C0070008	4P106C03800B0	277831716	277191067	4H300D0200000	
	Qty	1	1	1	1	1	
10	MODEL	-	-	7MBP50RA120	6RI30G-160	AFB0824SH	
	CODE	4P101C0070008	4P106C03800C8	277831686	277191067	4H300D0200000	
	Qty	1	1	1	1	1	
15	MODEL	-	-	7MBP50RA120	DF50AA160	AFB0824SH	
	CODE	4P101C0070008	4P106C03700C2	277831686	277192225	4H300D1440004	
	Qty	1	1	1	1	2	
20	MODEL	-	-	7MBP75RA120	DF50AA160	AFB0824SH	
	CODE	4P101C0070008	4P106C03700D1	277831538	277192225	4H300D1440004	
	Qty	1	1	1	1	2	
25	MODEL	-	-	7MBP075RA120	DF75LA160	AFB0824SH-B	
	CODE	4P101C0070008	4P106C03700D1	277831538	277192195	4H300D1440004	
	Qty	1	1	1	1	2	
30	MODEL	-	-	7MBP075RA120	DF75LA160	AFB0824SH-B	
	CODE	4P101C0070008	4P106C03700D1	277831538	277192195	4H300D1440004	
	Qty	1	1	1	1	2	
40	MODEL	-	-	CM100DU-24F	DF75LA160	A2123-HBT	ASB0624H
	CODE	4P101C0070008	4P106C02900A2	277810280	277192195	4M903D1890001	4H300D3330001
	Qty	1	1	3	1	2	1
50	MODEL	-	-	CM150DU-24F	DF100LA160	A2123-HBT	ASB0624H
	CODE	4P101C0070008	4P106C02900A2	277810298	277192217	4M903D1890001	4H300D3330001
	Qty	1	1	3	1	2	1
60	MODEL	-	-	CM150DU-24F	2U/DDB6U145N16L	A2123-HBT	ASB0624H
	CODE	4P101C0070008	4P106C02900A2	277810298	277190222	4M903D1890001	4H300D3330001
	Qty	1	1	3	1	2	1
75	MODEL	-	-	CM200DU-24F	2U/DDB6U145N16L	AFB1224SHE	AFB0824SH
	CODE	4P101C0070008	4P106C02900A2	277810301	277190222	4M300D3670007	4H300D3340007
	Qty	1	1	3	1	2	1
100	MODEL	-	-	CM300DU-24F	2U/DDB6U205N16L	AFB1224SHE	AFB0824SH
	CODE	4P101C0070008	4P106C02900A2	277810310	277190249	4M300D3670007	4H300D3340007
	Qty	1	1	3	1	2	1
125	MODEL	-	-	CM400HU-24F	2RI60G-160	AFB1224SHE	A2123-HBT
	CODE	4P101C0070008	4P106C02700A1	277800217	277051541	4M300D3670007	4M903D1890001
	Qty	1	1	6	6	3	1
150	MODEL	-	-	CM400HU-24F	2RI100G-160	AFB1224SHE	A2123-HBT
	CODE	4P101C0070008	4P106C02700A1	277800217	277051524	4M300D3670007	4M903D1890001
	Qty	1	1	6	6	3	1
175	MODEL	-	-	CM600HU-24F	2RI100G-160	AFB1224SHE	A2123-HBT
	CODE	4P101C0070008	4P106C02700A1	277800225	277051524	4M300D3670007	4M903D1890001
	Qty	1	1	6	6	3	1
215	MODEL	-	-	CM600HU-24F	2RI100G-160	EFB1524HHG	A2123-HBT
	CODE	4P101C0070008	4P106C02700A1	277800225	277051524	4M300D3680002	4M903D1890001
	Qty	1	1	6	6	3	1
250	MODEL	-	-	CM600HU-24F	2RI100G-160	EFB1524HHG	A2123-HBT
	CODE	4P101C0070008	4P106C02700A1	277800225	277051524	4M300D3680002	4M903D1890001
	Qty	1	1	6	6	3	1
300	MODEL	-	-	CM400HU-24F	2RI100G-160	EFB1524HHG	A2123-HBT
	CODE	4P101C0070008	4P106C02700B0	277800217	277051524	4M300D3680002	4M903D1890001
	Qty	1	1	12	6	3	1
350	MODEL	-	-	Skiip1013GB122-2DL	SKKH330/E16	2RRE45250 * 56R	
	CODE	4P101C0070008	3P106C0060009	4M903D2020001	4M903D1990006	4M903D1940009	
	Qty	1	1	3	3	1	
400	MODEL	-	-	Skiip1203GB122-2DL	SKKH500/E16	2RRE45250 * 56R	
	CODE	4P101C00700A6	3P106C0060009	4M903D2030006	4M903D2000000	4M903D1940009	
	Qty	1	1	3	3	2	
500	MODEL	-	-	Skiip1513GB122-3DL	SKKH500/E16	2RRE45250 * 56R	
	CODE	4P101C0070008	3P106C0060009	4M903D2040001	4M903D2000000	4M903D1940009	
	Qty	1	1	3	3	2	

## 7. SPECIFICATIONS

### ● Basic Specifications

#### 230V CLASS

INVERTER (HP)		5	7.5	10	15	20	25	30	40	50	60	75	100	125
MAX. APPLICABLE MOTOR OUTPUT HP (KW)*1		5 (3.7)	7.5 (5)	10 (7.5)	15 (11)	20 (15)	25 (18.5)	30 (22)	40 (30)	50 (37)	60 (45)	75 (55)	100 (75)	125 (90)
Output Characteristics	Inverter Capacity (KVA)	6.2	9.3	12.4	18.6	24.8	27.4	33	44	55	63	81	110	125
	Rated Output Current (A)	16	24	32	48	64	72	88	117	144	167	212	288	327
	Max. Output Frequency	3-Phase, 200~240V (Proportional to input voltage)												
	Rated Output Frequency	Up to 180Hz available												
Power Supply	Rated Input Voltage And Frequency	3-Phase, 200~240V, 50Hz 200/208/220/230V, 60Hz												
	Allowable Voltage Fluctuation	+10% ~ -15%												
	Allowable Frequency Fluctuation	±5%												

#### 460V CLASS

INVERTER (HP)		5	7.5	10	15	20	25	30	40	50	60	75	100	125	150	175	215	250	300	350	400	500
MAX. APPLICABLE MOTOR OUTPUT HP (KW)*1		5 (3.7)	7.5 (5)	10 (7.5)	15 (11)	20 (15)	25 (18.5)	30 (22)	40 (30)	50 (37)	60 (45)	75 (55)	100 (75)	125 (90)	150 (110)	175 (132)	215 (160)	250 (185)	300 (220)	350 (260)	400 (300)	500 (375)
Output Characteristics	Inverter Capacity (KVA)	6.2	9.3	12.4	18.6	24.8	29	34	45	57	66	85	115	144	176	203	232	259	290	393	446	558
	Rated Output Current (A)	8	12	16	24	32	38	44	59	75	86	111	151	189	231	267	304	340	380	516	585	732
	Max. Output Frequency	3-Phase, 380~480V (Proportional to input voltage)																				
	Rated Output Frequency	Up to 180Hz available																				
Power Supply	Rated Input Voltage And Frequency	3-Phase, 380~480V, 50/60Hz																				
	Allowable Voltage Fluctuation	+10% ~ -15%																				
	Allowable Frequency Fluctuation	±5%																				

- Based on 4 pole motor

## ● CHARACTERISTICS

Control Characteristics	Control Method	Sine wave PWM
	Frequency Control Range	0.1 to 180Hz
	Frequency Accuracy	+14 to 104      77 ± 18 Digital command: 0.01% -10 to 40      Analog command: 0.1% 25 ± 10
	Frequency Setting Resolution	Digital operator reference: 0.01Hz Analog reference: 0.06Hz/60Hz
	Output Frequency Resolution	0.01Hz (1/30000)
	Overload Capacity	110%      rated output current for one minute.
	Frequency Setting Signal	0 to 10VDC (20KΩ), 4~20mA (250Ω), 0 ~ ± 10 (option)
	Accel/Decel time	0.1 to 6000 sec (independent Accel/Decel time settings)
	Braking Torque	Approximately 20%
	No. of V/f patterns (Total of 5)	1: For adjustable pattern. 4: For fans and pumps.
Protective Functions	Motor Overload Protection	Electric thermal overload relay
	Instantaneous Overcurrent	Motor coasts to stop at approx. 200% rated current.
	Overload	Motor coasts to stop after 1 minute at 110% rated output current.
	Overvoltage (460V class)	Motor coasts to stop if inverter output voltage exceeds 820VDC.
	Overvoltage (230V class)	Motor coasts to stop if inverter output voltage exceeds 410VDC.
	Undervoltage (460V class)	Motor coasts to stop if inverter output voltage drops to 380VDC or below.
	Undervoltage (230V class)	Motor coasts to stop if inverter output voltage drops to 190VDC or below.
	Momentary Power Loss*1	Motor coasts to stop after momentary power loss lasting over 15ms. (time-setting made before shipment).
	Motor Overheat Protection	Motor PTC thermistor (Active: 1330Ω, Return: 550Ω)
	Input phase Loss	Single phase protection.
	Output phase Loss	Provided by electronic circuit.
	Fin Overheat	Thermostat
	Stall Prevention	Stall prevention at acceleration/deceleration and constant speed operation.
	Ground Fault	Provided by electronic circuit.
Power Charge Indication	Charge lamp stays ON until bus voltage drops below 50V.	
Environmental Conditions	Location	Indoor (Protected from corrosive gases and dust)
	Ambient Temperature	Wall-mounted type: +14 to 104      (-10 to +40      ),(not frozen) Open chassis type: +14 to 113      (-10 to +45      ), (not frozen)
	Storage Temperature	-4 to 140      (-20 to +60      )
	Humidity	95% RH (non-condensing)
	Vibration	1G at 10 to 20Hz, up to 0.2G at 20 to 50Hz.
Communication Function	RS-485 MODBUS, PROFIBUS (option)	
Noise Interference Suppression	EN 61800-3 (2000) with specified noise filter	
Noise Immunity	EN61800-3 (2000)	

## 8. DIMENSIONS

Table 7 Dimension and Weight

Voltage (V)	Inverter Capacity (HP)	Open Chassis Type (IP00) mm						Weight (Kg)	Enclosed Type (NEMA1) mm						Weight (Kg)	ACL/DCL	Reference Figure	
		W	H	D	W1	H1	d		W	H	D	W1	H1	d				
220V	5	211.2	300	215	192	286	M6	5.6	211.2	300	215	192	286	M6	5.6	External ACL (option)	(a)	
	7.5																	
	10																	
	15	265	360	225	245	340	M6	12	265	360	225	245	340	M6	12	External ACL (option)	(a)	
	20																	
	25																	
	30	283.5	525	307	220	505	M8	36	291.5	685	307	220	505	M8	38	DCL Built-in (Standard)	(b)	
	40																	
	50																	
	60	344	630	324.5	250	610	M8	47	352	790	324.5	250	610	M8	50	DCL Built-in (Standard)		
	75																	
	100	459	790	324.6	320	760	M10	82	462	1105	324.6	320	760	M10	87	DCL Built-in (Standard)		
125																		
440V	5	211.2	300	215	192	286	M6	5.6	211.2	300	215	192	286	M6	5.6	External ACL (option)		(a)
	7.5																	
	10																	
	15	265	360	225	245	340	M6	12	265	360	225	245	340	M6	12	External ACL (option)		(a)
	20																	
	25																	
	30	283.5	525	307	220	505	M8	36	291.5	685	307	220	505	M8	38	DCL Built-in (Standard)	(b)	
	40																	
	50																	
	60	344	630	324.5	250	610	M8	47	352	790	324.5	250	610	M8	50	DCL Built-in (Standard)		
	75																	
	100	459	790	324.6	320	760	M10	80	462	1105	324.6	320	760	M10	85	DCL Built-in (Standard)		
	125																	
	150	599	1000	381.6	460	960	M12	128	602	1305	381.6	460	960	M12	135	DCL Built-in (Standard)		
	175																	
	215	730	1230	382	690	930	M12	132	730	1330	382	690	930	M12	166	External ACL (option)		(c)
	250																	
300	170	196	196	196	196	196	196	196	196	196	196	196	196	196	196	196		
350																		
400																		
500	730	1230	382	690	930	M12	170	730	1330	382	690	930	M12	176	External ACL (option)	(d)		
500																		

(a) 220V : 5HP~25HP  
440V : 5HP~30HP

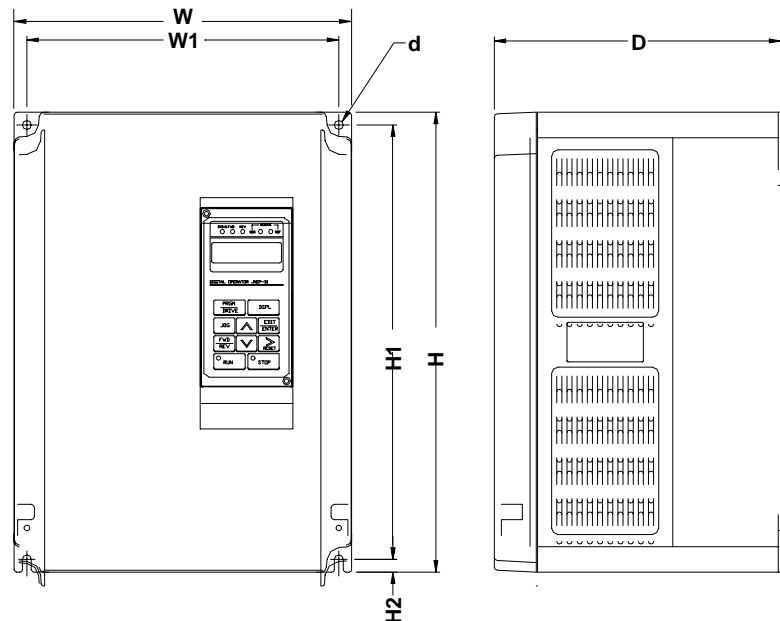

(b) 220V : 30HP 125HP  
 440V : 40HP 300HP

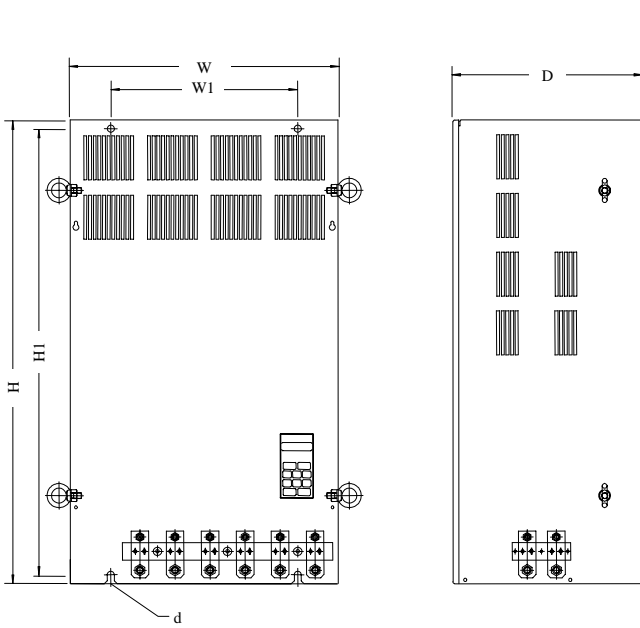

( Open Chassis Type - IP00 )

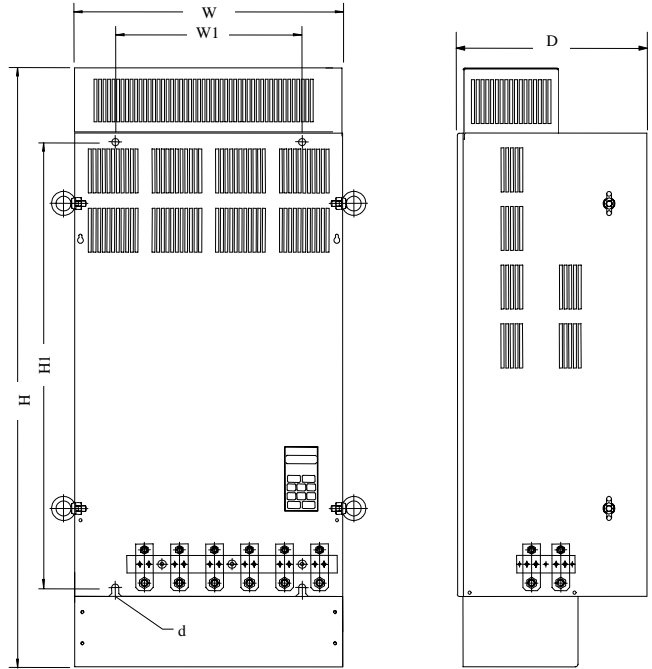

( Wall-mounted Type - NEMA1 )

(c) 440V : 350HP

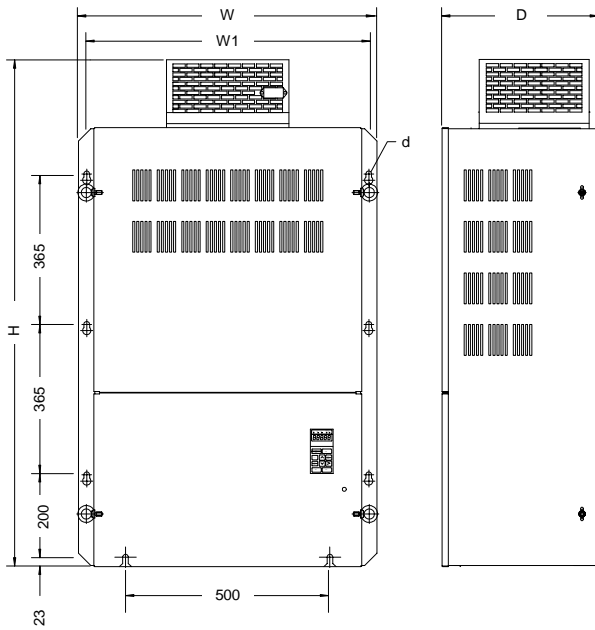

( Open Chassis Type - IP00 )

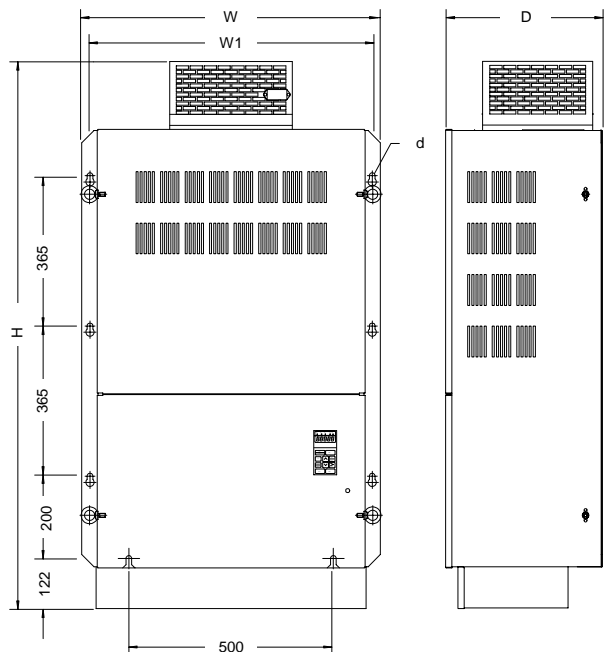

( Wall-mounted Type - NEMA1 )

(d) 440V : 400HP, 500HP

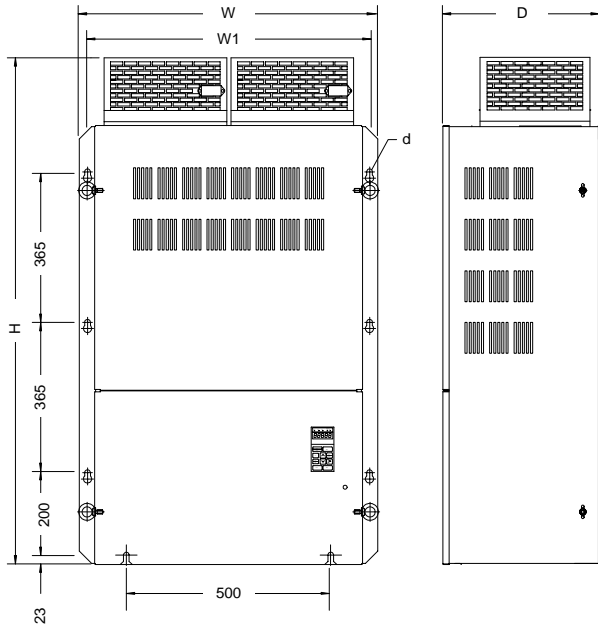

( Open Chassis Type - IP00 )

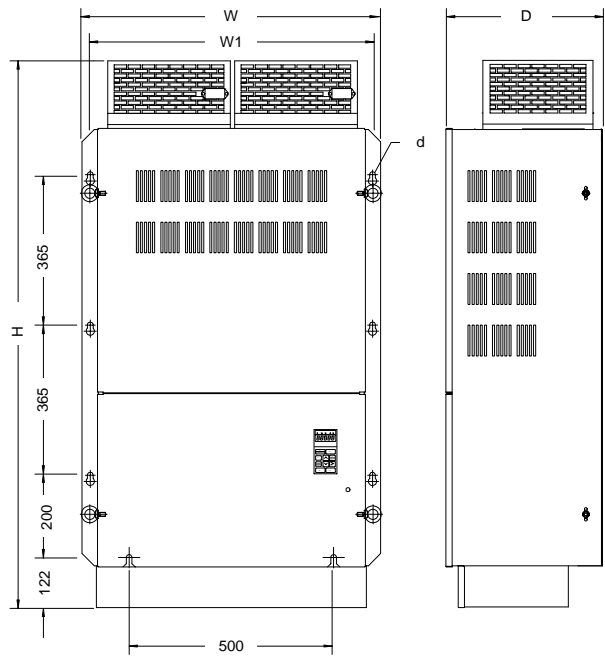

( Wall-mounted Type - NEMA1 )

## 9. PERIPHERAL AND OPTIONS

### 9.1 AC REACTOR

- When power capacity is significantly large compared to inverter capacity, or when the power factor needs to be improved, externally connect an AC reactor.
- 7300PA 220V 30 ~ 125HP and 440V 40 ~300HP have built-in DC reactor as standard. (When the power factor needs to be improved, externally connect an AC reactor).
- 220V 25HP and 440V 25HP, 30HP connect an optional AC reactor When the power factor needs to be improved.
- 440V 350 ~500HP need to connect an AC reactor externally.

Table 8 AC REACTOR

Voltage	Inverter		AC Reactor	
	HP	Rated current (A)	Current (A)	Inductance (mH)
220V	5	16	20	0.53
	7.5	24	30	0.35
	10	32	40	0.265
	15	48	60	0.18
	20	64	80	0.13
	25	72	90	0.12
	30	88	90	0.12
	40	117	120	0.09
	50	144	160	0.07
	60	167	160	0.07
	75	212	240	0.044
	100	288	360	0.026
	125	327	360	0.026
440V	5	8	10	2.2
	7.5	12	15	1.42
	10	16	20	1.06
	15	24	30	0.7
	20	32	40	0.53
	25	38	50	0.42
	30	44	50	0.42
	40	59	60	0.36
	50	75	80	0.26
	60	86	90	0.24
	75	111	120	0.18
	100	151	200	0.11
	125	189	200	0.11
	150	231	250	0.09
	175	267	330	0.06
	215	304	330	0.06
	250	340	400	0.05
300	380	500	0.04	
350	516	670	0.032	
400	585	670	0.032	
500	732	800	0.025	

## 9.2 NOISE FILTER

### 9.2.1 INPUT NOISE FILTER

- When input noise filter is installed as indicated, the 440V series of 7300PA will comply with the EN61800-3 (2000) noise interference suppression directive.

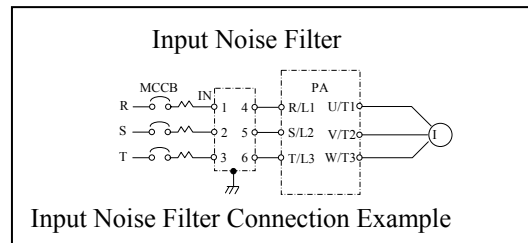
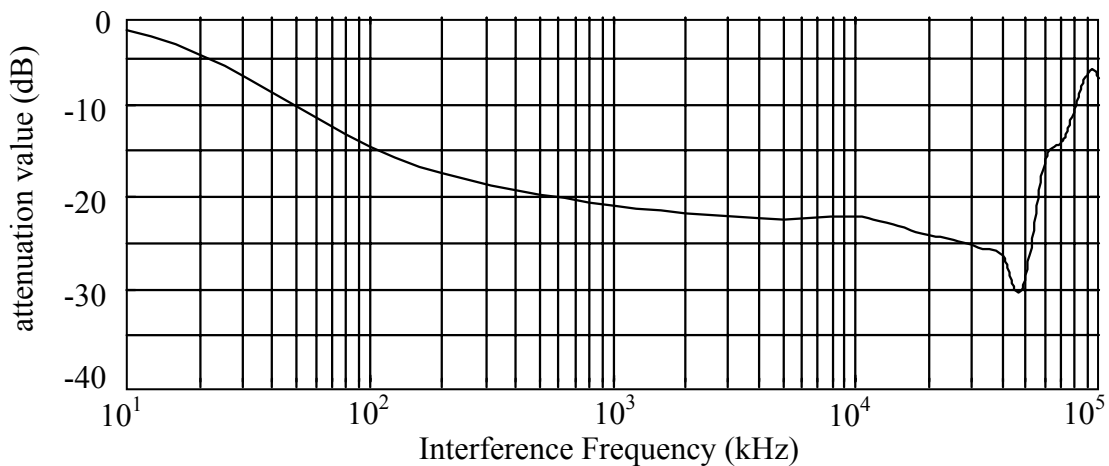

Table 9 Input Noise Filter

Voltage (V)	Inverter		Input Noise Filter		
	HP	Rated current (A)	Code NO.	Model NO.	Rated current (A)
220V	25	72A	4H000D1690004	FS6100-90-34	90A
	30	88A	4H000D1690004	FS6100-90-34	90A
	40	117A	4H000D1710005	FS6100-150-40	150A
	50	144A	4H000D1710005	FS6100-150-40	150A
	60	167A	4H000D1720001	FS6100-250-99	250A
	75	212A	4H000D1720001	FS6100-250-99	250A
	100	288A	4H000D1750007	FS6100-400-99	400A
	125	327A	4H000D1750007	FS6100-400-99	400A
440V	5	8A	JNKMF325A	KMF325A	25A
	7.5	12A	JNKMF325A	KMF325A	25A
	10	16A	JNKMF325A	KMF325A	25A
	15	24A	JNKMF350A	KMF350A	50A
	20	32A	JNKMF350A	KMF350A	50A
	25	38A	4H000D1770008	FS6101-50-52	50A
	30	44A	4H000D1770008	FS6101-50-52	50A
	40	59A	4H000D1790009	FS6101-80-52	80A
	50	75A	4H000D1790009	FS6101-80-52	80A
	60	86A	4H000D1800004	FS6101-120-35	120A
	75	111A	4H000D1800004	FS6101-120-35	120A
	100	151A	4H000D1820005	FS6101-200-40	200A
	125	189A	4H000D1820005	FS6101-200-40	200A
	150	231A	4H000D1850001	FS6101-320-99	320A
	175	267A	4H000D1850001	FS6101-320-99	320A
	215	304A	4H000D1850001	FS6101-320-99	320A
	250	340A	4H000D1880008	FS6101-400-99	400A
	300	380A	4H000D1880008	FS6101-400-99	400A
350	516A	4H000D1900009	FS6101-600-99	600A	
400	585A	4H000D1900009	FS6101-600-99	600A	
500	732A	4H000D1910004	FS6101-800-99	800A	

## 9.2.2 EMI SUPPRESSION ZERO CORE

- Model: JUNFOC046S - - - - -
- Code No.: 4H000D0250001
- According to the required power rating and wire size, select the matched ferrite core to suppress the zero sequence EMI filter.
- The ferrite core can attenuate the frequency response at high frequency range (from 100KHz to 50MHz, as shown below). It should be able to attenuate the RFI from inverter to outside.
- The zero-sequence noise filter ferrite core can be installed either on the input side or on the output side. The wire around the core for each phase should be wound by following the same convention and one direction. The more winding turns the better attenuation effect. (Without saturation). If the wire size is too big to be wound, all the wire can be grouped and go through these several cores together in one direction.
- Frequency attenuation characteristics (10 windings case)



Example: EMI suppression zero core application example

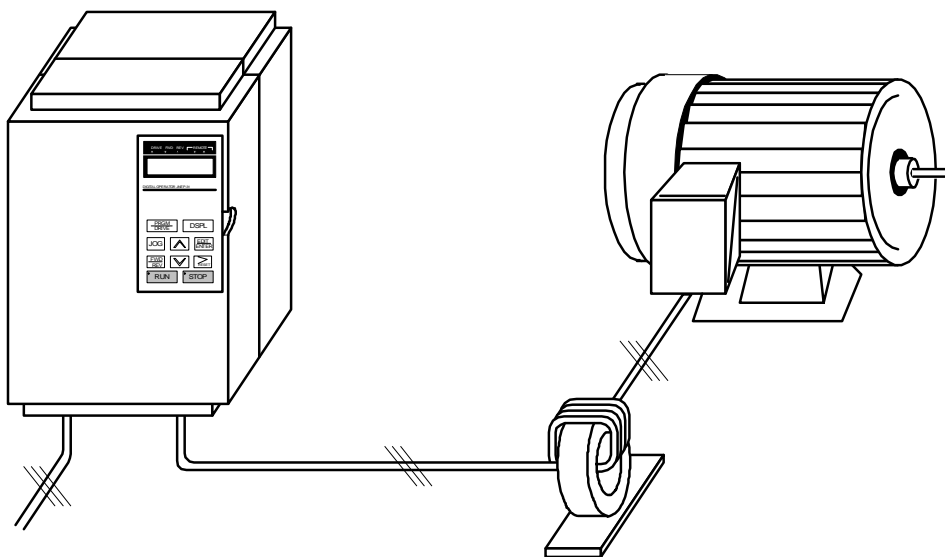

Note: All the line wire of U/T1, V/T2, W/T3 phase must pass through the same zero-phase core in the same winding sense.

### 9.3 BRAKING RESISTOR AND BRAKING UNIT

- The braking transistor of 220V 5~25HP and 440V 5~30HP was built-in as standard, the braking resistor can be connected to main circuit terminals B2 and + directly. The others without built-in braking transistor need to connect braking unit with braking resistor externally.
- When connecting braking resistor or braking unit with braking resistor, set system parameter Sn-10=XX10 (i.e. stall prevention during deceleration not enabled).
- Braking resistor and braking unit selection table is shown below.

Table 10 Braking Resistor and Braking Unit

Inverter			Braking Unit		Braking Resistor			Braking Torque (%)
Voltage	HP	Rated current (A)	Model	Number used	Code NO.	Specs.	Number used	
220V	5	16	-	-	JNBR-390W40	390W/40Ω	1	119%(10%ED)
	7.5	24	-	-	JNBR-520W30	520W/30Ω	1	108%(10%ED)
	10	32	-	-	JNBR-780W20	780W/20Ω	1	119%(10%ED)
	15	48	-	-	JNBR-2R4KW13R6	2400W/13.6Ω	1	117%(10%ED)
	20	64	-	-	JNBR-3KW10	3000W/10Ω	1	119%(10%ED)
	25	72	-	-	JNBR-3KW10	3000W/10Ω	1	99%(10%ED)
	30	88	JNTBU-230	1	JNBR-4R8KW6R8	4800W/6.8Ω	1	117%(10%ED)
	40	117	JNTBU-230	2	JNBR-3KW10	3000W/10Ω	2	119%(10%ED)
	50	144	JNTBU-230	2	JNBR-3KW10	3000W/10Ω	2	99%(10%ED)
	60	167	JNTBU-230	2	JNBR-4R8KW6R8	4800W/6.8Ω	2	117%(10%ED)
	75	212	JNTBU-230	2	JNBR-4R8KW6R8	4800W/6.8Ω	2	98%(10%ED)
	100	288	JNTBU-230	3	JNBR-4R8KW6R8	4800W/6.8Ω	3	108%(10%ED)
125	327	JNTBU-230	3	JNBR-4R8KW6R8	4800W/6.8Ω	3	90%(10%ED)	
440V	5	8	-	-	JNBR-400W150	400W/150Ω	1	126%(10%ED)
	7.5	12	-	-	JNBR-600W130	600W/130Ω	1	102%(10%ED)
	10	16	-	-	JNBR-800W100	800W/100Ω	1	99%(10%ED)
	15	24	-	-	JNBR-1R6KW50	1600W/50Ω	1	126%(10%ED)
	20	32	-	-	JNBR-1R6KW50	1600W/50Ω	1	99%(10%ED)
	25	38	-	-	JNBR-1R6KW50	1600W/50Ω	1	84%(10%ED)
	30	44	-	-	JNBR-1R6KW50	1600W/50Ω	1	73%(10%ED)
	40	59	JNTBU-430	1	JNBR-6KW20	6000W/20Ω	1	119%(10%ED)
	50	75	JNTBU-430	2	JNBR-4R8KW32	4800W/32Ω	2	119%(10%ED)
	60	86	JNTBU-430	2	JNBR-4R8KW27R2	4800W/27.2Ω	2	117%(10%ED)
	75	111	JNTBU-430	2	JNBR-6KW20	6000W/20Ω	2	126%(10%ED)
	100	151	JNTBU-430	3	JNBR-6KW20	6000W/20Ω	3	139%(10%ED)
	125	189	JNTBU-430	3	JNBR-6KW20	6000W/20Ω	3	115%(10%ED)
	150	231	JNTBU-430	3	JNBR-6KW20	6000W/20Ω	3	99%(10%ED)
	175	267	JNTBU-430	5	JNBR-6KW20	6000W/20Ω	5	134%(10%ED)
	215	304	JNTBU-430	6	JNBR6KW20	6000W/20Ω	6	131%(10%ED)
	250	340	JNTBU-430	6	JNBR-6KW20	6000W/20Ω	6	115%(10%ED)
	300	380	JNTBU-430	6	JNBR-6KW20	6000W/20Ω	6	99%(10%ED)
350	516	JNTBU-430	7	JNBR-6KW20	6000W/20Ω	7	99%(10%ED)	
400	585	JNTBU-430	9	JNBR-6KW20	6000W/20Ω	9	109%(10%ED)	
500	732	JNTBU-430	11	JNBR6KW20	6000W/20Ω	11	107%(10%ED)	

\*Note: Another choices are listed as below. (JUVPHV-0060 no UL certification)

440V 50HP: (JUVPHV-0060+JNBR-9R6KW16)x1

440V 100HP: (JUVPHV-0060+JNBR-9R6KW13R6)x2

440V 175HP: (JUVPHV-0060+JNBR-9R6KW13R6)x3

440V 250HP: (JUVPHV-0060+JNBR-9R6KW13R6)x4

440V 350HP: (JUVPHV-0060+JNBR-9R6KW13R6)x6

440V 500HP: (JUVPHV-0060+JNBR-9R6KW13R6)x8

440V 60HP: (JUVPHV-0060+JNBR-9R6KW13R6)x1

440V 125HP: (JUVPHV-0060+JNBR-9R6KW13R6)x2

440V 215HP: (JUVPHV-0060+JNBR-9R6KW13R6)x4

440V 300HP: (JUVPHV-0060+JNBR-9R6KW13R6)x5

440V 400HP: (JUVPHV-0060+JNBR-9R6KW13R6)x6

\*Note: When set up braking unit and resistor, please make sure there is adequately ventilated environment and appropriate distance for setting

## 9.4 OTHERS

### 9.4.1 DIGITAL OPERATOR WITH EXTENSION WIRE

- Used for the operation of LCD (or LED) digital operator or monitor when removed from the front of inverter unit.

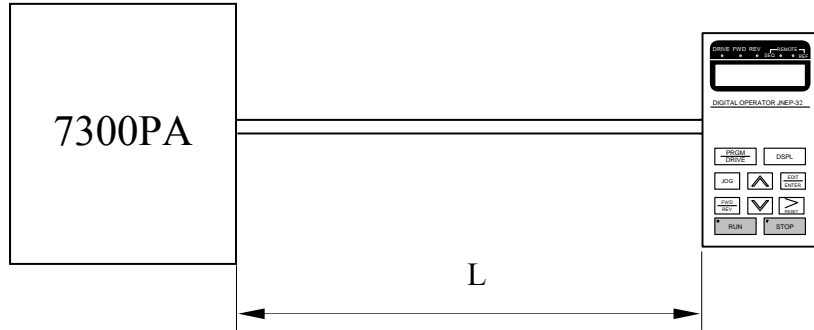

Cable Length	Extension Cable Set*1	Extension Cable Set*2	Blank Cover*3
1m	4H332D0010000	4H314C0010003	4H300D1120000
2m	4H332D0030001	4H314C0030004	
3m	4H332D0020005	4H314C0020009	
5m	4H332D0040006	4H314C0040000	

\*1 : Including special cable for LCD (or LED) operator, blank cover, fixed use screws and installation manual.

\*2 : One special cable for digital operator.

\*3 : A blank cover to protect against external dusts, metallic powder, etc.

- The physical dimension of LCD (or LED) digital operator is drawn below.

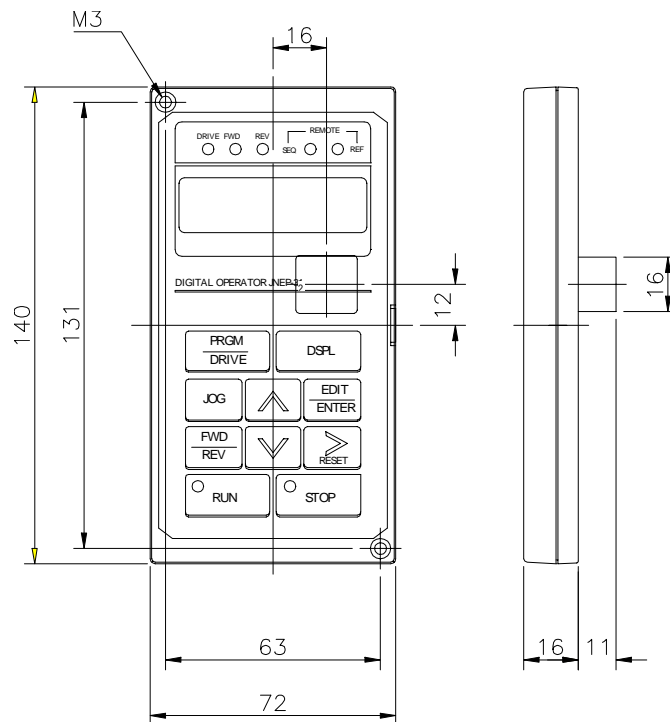

**Fig. 6 LCD Digital Operator Dimension**

## 9.4.2 ANALOG OPERATOR

All 7300PA have the LCD (or LED) digital operator. Moreover, an analog operator as JNEP-17 (shown in fig. 7) is also available and can be connected through wire as a portable operator. The wiring diagram is shown below.

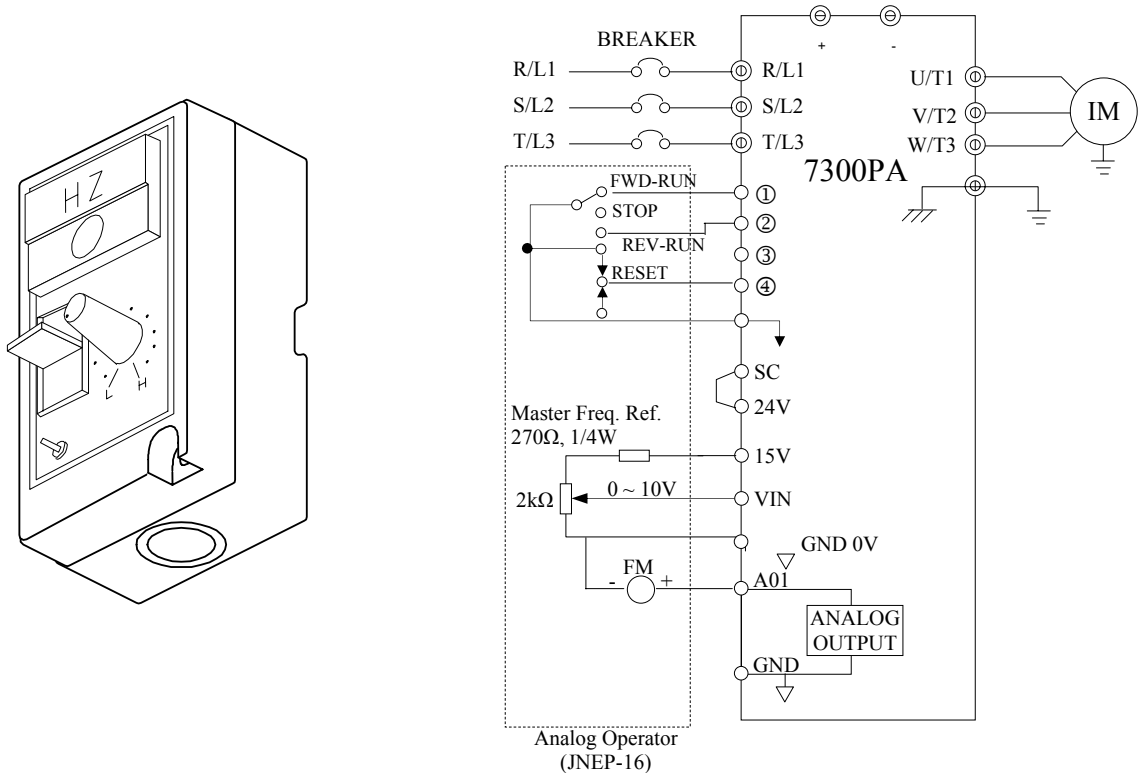

**Fig. 7 Analog Operator**

## 9.4.3 LED DIGITAL OPERATOR

- All 7300PA have standard with LCD digital operator (JNEP-32). Moreover, an LED digital operator JNEP-33 (shown in Fig. 9-b) is also available and can be connected through the same cable and connector.
- The LED digital operator has the same installation and dimension with the LCD digital operator.

## 9.4.4 1-TO-8 PID RELAY CARD

- Used in the constant pressure water supply system.
- The PA-PID option card has the same installation with the RS-485 communication option card (PA-M or PA-P).

### 9.4.5 COMMUNICATION OPTION CARD

Name	Code NO.	Function
PA-M	4H300D2950006	MODBUS protocol communication optional card ● Communication method: Asynchronous ● Communication speed: 19.2Kbps (max.) ● Interface: RS-485, RS-422
PA-P	JNPA-P	PROFIBUS protocol communication optional card ● Communication method: Asynchronous ● Communication speed: depend ● Interface: RS-485
PA-L	JNPA-L	LONWORKS protocol communication optional card ● Communication method: Asynchronous ● Communication speed: 78 Kbps ● Interface: Manchester
PA-C	JNPA-C	MODBUS ASCII, METASYS N2 protocol communication optional card ● Communication method: Asynchronous ● Communication speed: MODBUS ASCII: 19.2KBPS ( max. ) METASYS N2: 9.6KBPS ● Interface: RS-485

- PA-P and PA-PID only for the inverter software Ver.0403.
- The Communication option card can be mounted on the upper side of control board CN2 connector.
- Use the following procedure to install three option card.
  1. Turn off the main-circuit power supply.
  2. Leave it off for at least one minute before removing the front cover of the inverter. Check to be sure that the CHARGE indicator is OFF.
  3. Insert the spacer (Which is provided with the option card) into the spacer hole at the control board.
  4. Pass the spacer through the spacer hole at the option card. Check to be sure that it is precisely aligned with the CN2 position, and snap it into the proper position.

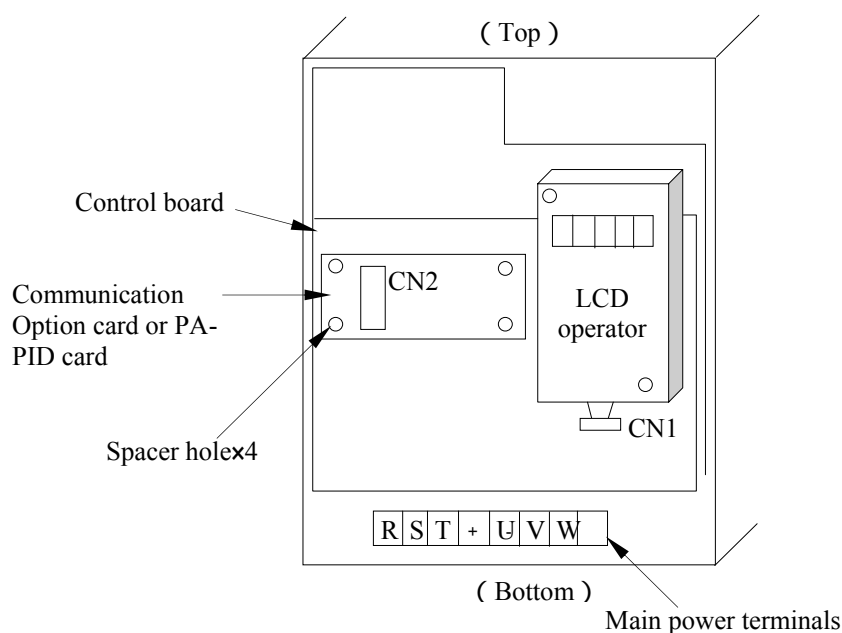

**Fig. 8 Option card Installation**

# **PART II**

# **OPERATION MANUAL**

# 1. DESCRIPTION OF USING 7300PA

## 1.1 Using LCD (or LED) digital operator

- 7300PA are standard with LCD digital operator JNEP-32. Moreover, an LED digital operator JNEP-33 is also available. Three two digital operator have the same operation functions except the LCD and 7-segments LED display difference.
- The LCD and LED digital operator has 2 modes: DRIVE mode and PRGM mode. When the inverter is stopped, DRIVE mode or PRGM mode can be selected by pressing the key . In DRIVE mode, the operation is enabled. Instead, in the PRGM mode, the parameter settings for operation can be changed but the operation is not enabled.

a. The LCD digital operator component names and functions shown as below:

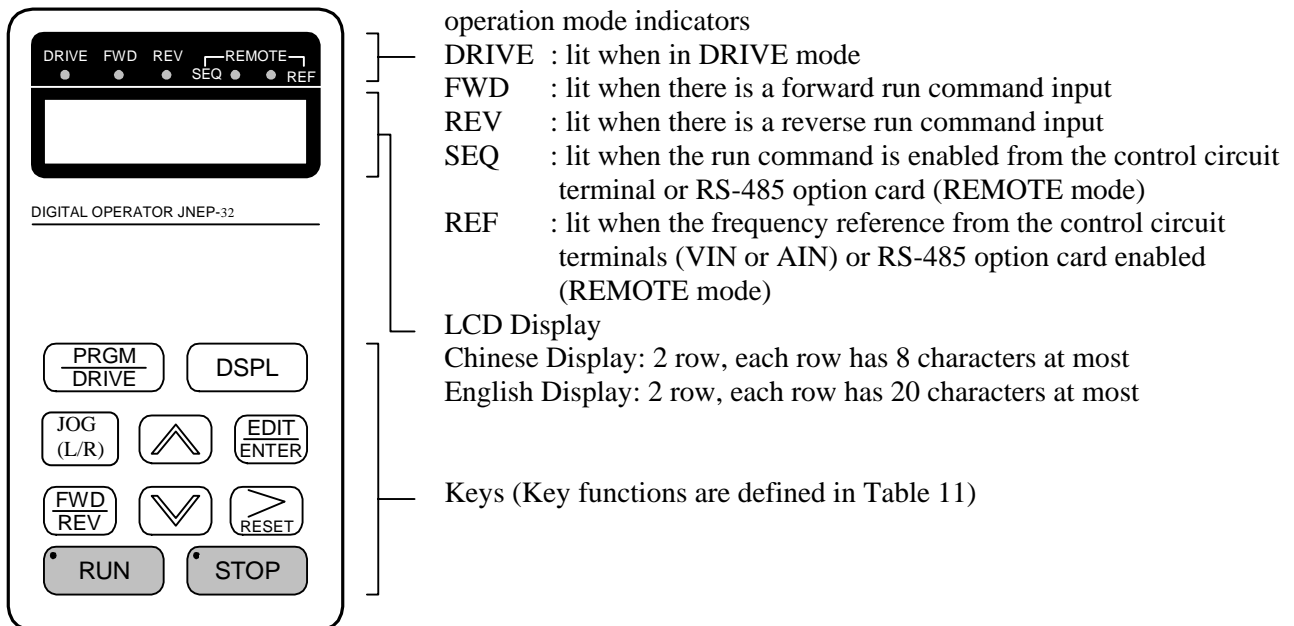





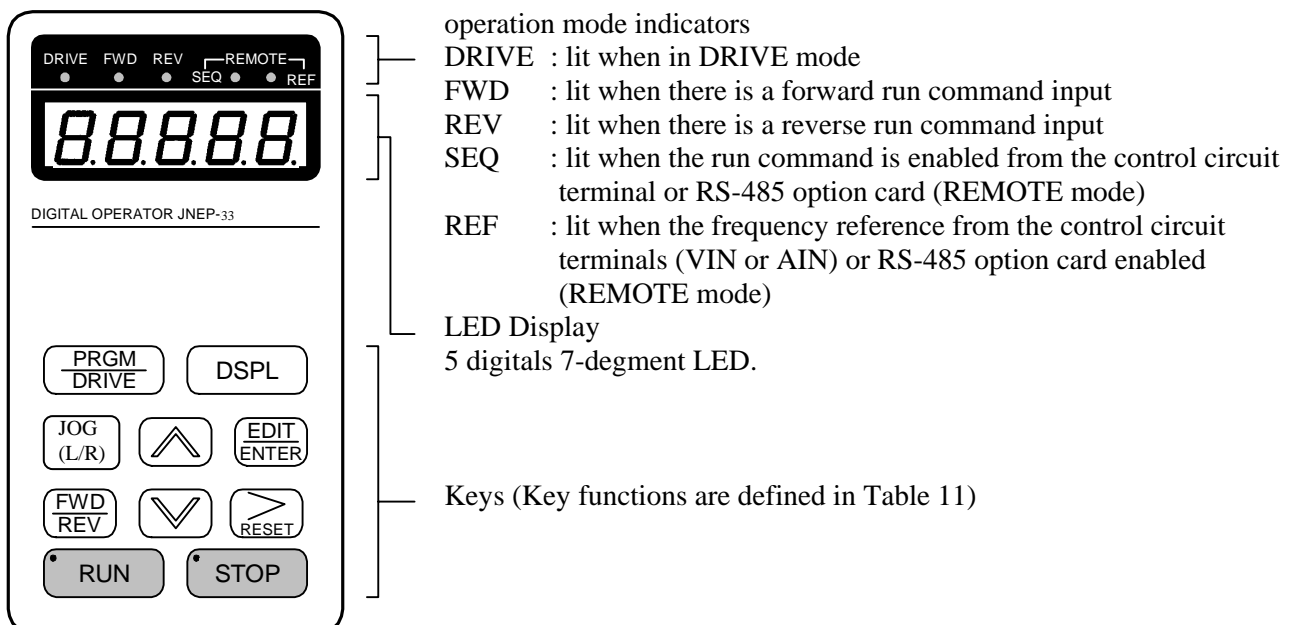





**Fig 9-a LCD Digital operator component names and functions**

b. The LED digital operator component names and functions shown as below:

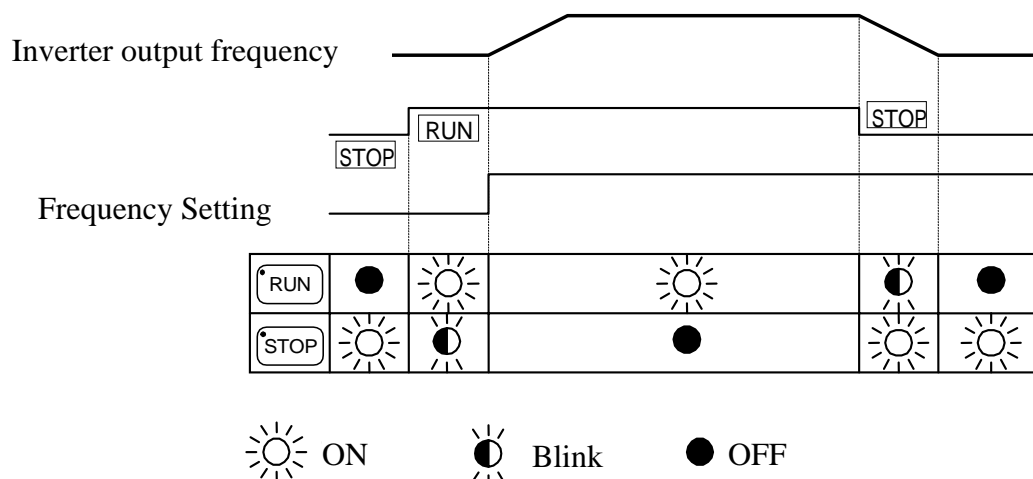

**Fig 9-b LED Digital operator component names and functions**

Table 11 Key's functions

Key	Name	Function
	PRGM/DRIVE key	Switches between operation (PRGM) and operation (DRIVE).
	DSPL key	Display operation status
	JOG or L/R key	Enable jog operation from digital operator in operation (DRIVE).L/R (Local/Remote)key function set by Sn-05.
	FWD/REV key	Select the rotation direction from digital operator.
	RESET key	Set the number of digital for user constant settings. Also it acts as the reset key when a fault has occurred.
	INCREMNT key	Select the menu items, groups, functions, and user constant name, and increment set values.
	DECREMENT key	Select the menu items, groups, functions, and user constant name, and decrement set values.
	EDIT/ENTER key	Select the menu items, groups, functions, and user constants name, and set values (EDIT). After finishing the above action, press the key (ENTER).
	RUN key	Start inverter operation in (DRIVE) mode when operator is used. The led will light.
	STOP key	Stop 7300PA operation from LCD digital operator. The key can be enable or disabled by setting a constant Sn-05 when operating from the control circuit terminal (in this case, the LED will light).

RUN, STOP indicator lights or blinks to indicate the 3 operating status:



## 1.2 DRIVE mode and PRGM mode displayed contents

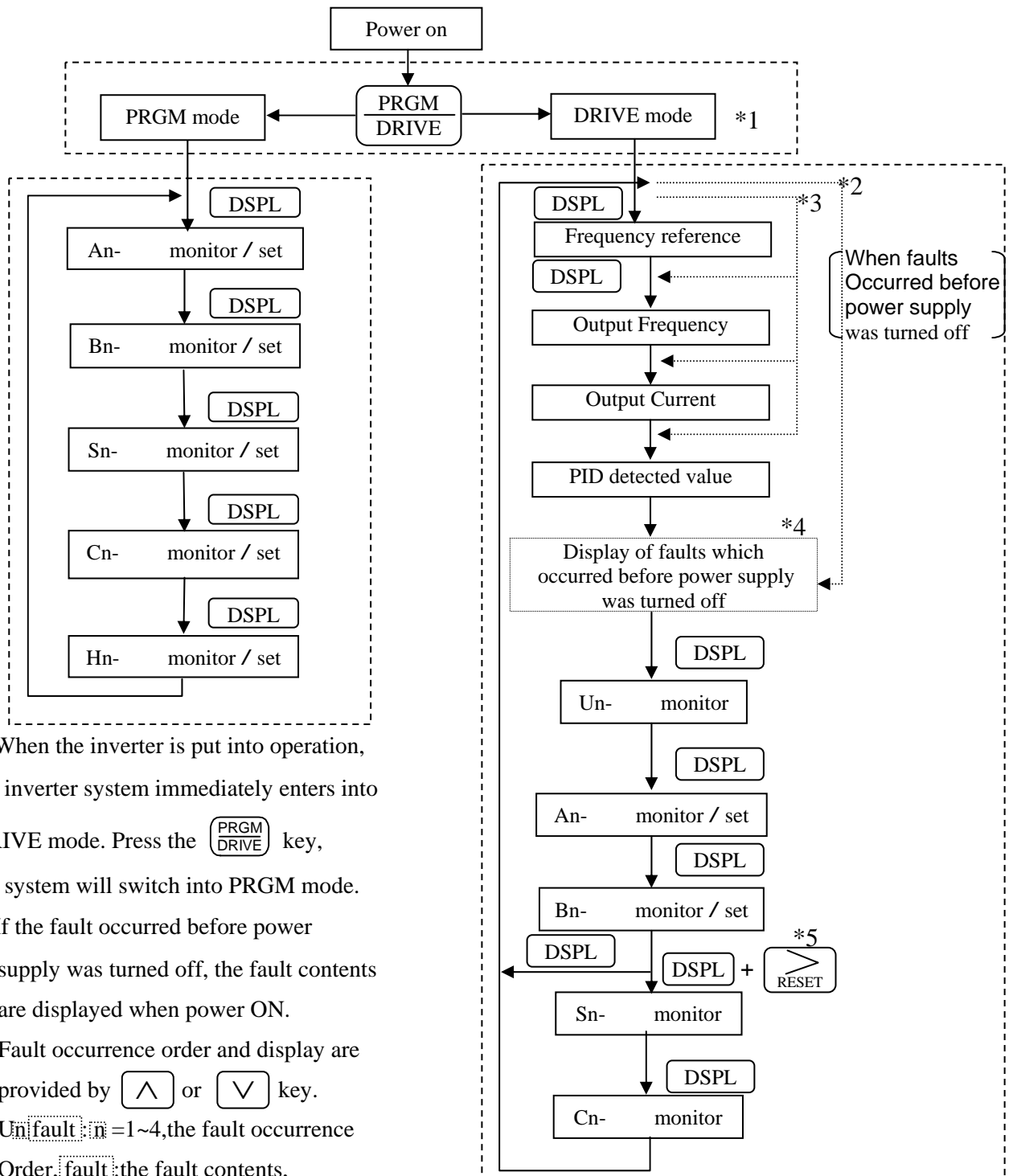

\*1 : When the inverter is put into operation, the inverter system immediately enters into DRIVE mode. Press the key, the system will switch into PRGM mode.

\*2 : If the fault occurred before power supply was turned off, the fault contents are displayed when power ON. Fault occurrence order and display are provided by or key.  $Un$  fault :  $n=1\sim 4$ , the fault occurrence Order,  $fault$  : the fault contents, please refer to Chapter3 fault display and trouble shooting.

\*3 : If no fault occurred before power supply was turned off , display the monitored data according to the Bn-10 setting

\*4 : This block will be by passed if no fault occurred before power supply was turned off or a fault occurs and was reset by

\*5 : When in the DRIVE mode, press the key and key, the setting values of Sn- and Cn- will only be displayed for monitoring but not for changing or setting.

### 1.3 Parameter description



The 7300PA has 4 groups of user parameters:

Parameters <sup>*4</sup>	Description
An-	Frequency command
Bn-	Parameter settings can be changed during running
Sn-	System parameter settings (can be changes only after stop)
Cn-	Control parameter settings (can be changed only after stop)

The parameter setting of Sn-03 (operation status) will determine if the setting value of different parameter groups are allowed to be changed or only to be monitored, as shown below:

Sn-03	DRIVE mode		PRGM mode	
	To be set	To be monitored	To be set	To be monitored
0000 <sup>*1</sup>	An, Bn	Sn, Cn	An, Bn, Sn, Cn	-
0101 <sup>*2</sup>	An	Bn, Sn, Cn	An	Bn, Sn, Cn

\*1 : Factory setting

\*2 : When in DRIVE mode, the parameter group Sn-, Cn- can only be monitored if the  key and the  key are to be pressed at the same time,

\*3 : After a few trial operation and adjustment, the setting value Sn-03 is set to be "0101" so as not be modified again.

\*4 : The 7300PA has 2 groups of monitoring parameters and one group of order parameters in addition to the above 4 groups of user parameters.

Un- : Can be monitored by the users under the DRIVE mode.

Hn- : Can be monitored by the users under the PRGM mode.

\*5 : On- : Order parameters can be monitored and changed by setting Sn-03=1010.

## 1.4 Example of using LCD digital operator

Note :

Before operation: Control parameter Cn-01 value must be set as the input AC voltage value. For example, Cn-01=380 if AC input voltage is 380.

This sample example will explain the operating of 7300PA according to the following time chart.

### OPERATION MODE

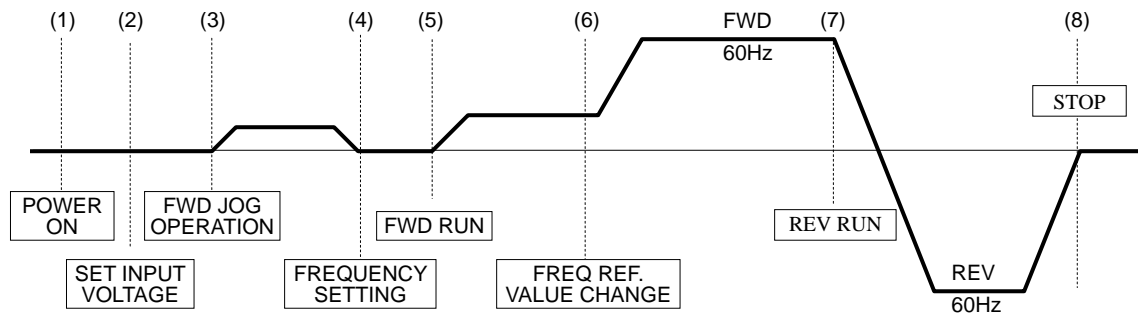

### Sample operation

Description	Key Sequence	Digital Operator Display	Remarks
<p>(1) When POWER ON</p> <ul style="list-style-type: none"> <li>● Sect frequency reference value displayed</li> <li>● Select PRGM mode</li> </ul> <p>(2) Input voltage setting (e.g. AC input voltage is 380V)</p> <ul style="list-style-type: none"> <li>● Select CONTROL PARAMETER</li> <li>● Display Cn-01 setting</li> <li>● Input Voltage 380V</li> </ul> <p>(continued)</p>	<p>PRGM DRIVE</p> <p>DSPL Press 3 times</p> <p>EDIT ENTER</p> <p>RESET ↑ ↓</p> <p>EDIT ENTER</p>	<p>Freq. Cmd. 00.00<sup>Hz</sup> TECO</p> <p>An-01 Freq. Cmd. 1</p> <p>Cn-01- Input Voltage</p> <p>Cn-01=440.0<sup>V</sup> Input Voltage</p> <p>Cn-01=380.0<sup>V</sup> Input Voltage</p> <p>Entry Accepted</p>	<p>LED <b>DRIVE</b> OFF</p> <p>Display for 0.5 sec</p>

Description	Key Sequence	Digital Operator Display	Remarks
(continued)			
<p>(3) FWD JOG</p> <ul style="list-style-type: none"> <li>Select DRIVE mode</li> <li>Select output frequency displayed</li> <li>Select direction of rotation (When power on, initially defaulted FWD)</li> <li>Jog operation</li> </ul>	<p></p> <p></p> <p></p>	<p>Freq. Cmd. 00.00<sup>Hz</sup><sub>TECO</sub></p> <p>Freq. Cmd. .0 Hz TECO</p> <p>O/P Freq. 6.00 Hz TECO</p>	<p>LED  ON</p> <p>LED  ON</p>
<p>(4) Frequency setting</p> <p>15Hz</p> <ul style="list-style-type: none"> <li>Select frequency cmd displayed</li> <li>Change frequency cmd</li> <li>Set new frequency cmd</li> <li>Select O/P frequency displayed</li> </ul>	<p> Press 4 times</p> <p> </p> <p></p> <p></p>	<p>Freq. Cmd. 00.00<sup>Hz</sup><sub>TECO</sub></p> <p>Freq. Cmd. 15.00<sup>Hz</sup><sub>TECO</sub></p> <p>Freq. Cmd. 15.00<sup>Hz</sup><sub>TECO</sub></p> <p>Entry Accepted</p> <p>O/P Freq. .0 Hz TECO</p>	<p>Display for 0.5 sec Confirm the display.</p>
<p>(5) FWD run</p> <ul style="list-style-type: none"> <li>Running operation</li> </ul>	<p></p>	<p>O/P Freq. 15.00 Hz TECO</p>	<p>LED  ON</p>
<p>(6) Frequency command change</p> <p>60Hz</p> <ul style="list-style-type: none"> <li>Select frequency cmd displayed</li> <li>Change reference value</li> <li>Enter new frequency cmd setting</li> <li>Select frequency cmd displayed</li> </ul>	<p> Press 4 times</p> <p> </p> <p></p> <p></p>	<p>Freq. Cmd. 15.00<sup>Hz</sup><sub>TECO</sub></p> <p>Freq. Cmd. 60.00<sup>Hz</sup><sub>TECO</sub></p> <p>Freq. Cmd. 60.00 Hz TECO</p> <p>Entry Accepted</p> <p>O/P Freq. 60.00 Hz TECO</p>	<p>Display for 0.5 sec Confirm the display.</p>
<p>(7) REV RUN</p> <ul style="list-style-type: none"> <li>Change to REV</li> </ul>	<p></p>	<p>O/P Freq. -60.00 Hz TECO</p>	<p>LED  ON</p>
<p>(8) STOP</p> <ul style="list-style-type: none"> <li>Decrement to STOP</li> </ul>	<p></p>	<p>O/P Freq. .0 Hz TECO</p>	<p>LED  ON</p> <p>(Blinking while decel.) </p>

## 2. SETTING USER CONSTANT

### 2.1 Frequency command (in Multi-speed operation) An -

Under the DRIVE mode, the user can monitor the parameters and set their values.

Parameter No.	Name	LCD Display (English)	Setting Range	Setting Unit	Factory Setting	Ref. Page
An-01	Frequency Command 1	An-01=000.00Hz Frequency Command 1	0.00 180.00 Hz	0.01Hz	00.00Hz	2-48 2-49 App-3
An-02	Frequency Command 2	An-02=000.00Hz Frequency Command 2	0.00 180.00 Hz	0.01Hz	0.00Hz	
An-03	Frequency Command 3	An-03=000.00Hz Frequency Command 3	0.00 180.00 Hz	0.01Hz	0.00Hz	
An-04	Frequency Command 4	An-04=000.00Hz Frequency Command 4	0.00 180.00 Hz	0.01Hz	0.00Hz	
An-05	Frequency Command 5	An-05=000.00Hz Frequency Command 5	0.00 180.00 Hz	0.01Hz	0.00Hz	
An-06	Frequency Command 6	An-06=000.00Hz Frequency Command 6	0.00 180.00 Hz	0.01Hz	0.00Hz	
An-07	Frequency Command 7	An-07=000.00Hz Frequency Command 7	0.00 180.00 Hz	0.01Hz	0.00Hz	
An-08	Frequency Command 8	An-08=000.00Hz Frequency Command 8	0.00 180.00 Hz	0.01Hz	0.00Hz	
An-09	Jog Frequency Command	An-09=006.00Hz Jog Command	0.00 180.00 Hz	0.01Hz	6.00Hz	

\*1. The displayed "Setting Unit" can be changed through the parameter Cn-20.

\*2. At factory setting, the value of "Setting Unit" is 0.01Hz.

\*3. The setting of An-01~16 should be with the multi-function analog terminals 5 ~ 8 .

## 2.2 Parameters Can Be Changed during Running Bn-

Under the DRIVE mode, the Parameter group can be monitored and set by the users.

Function	Parameter No.	Name	LCD Display (English)	Setting Range	Setting Unit	Factory Setting	Ref. Page
Acc/Dec time	Bn-01	Acceleration Time 1	Bn-01=0010.0s Acc. Time 1	0.0 6000.0s	0.1s	10.0s	2-4
	Bn-02	Deceleration Time 1	Bn-02=0010.0s Dec. Time 1	0.0 6000.0s	0.1s	10.0s	
	Bn-03	Acceleration Time 2	Bn-03=0010.0s Acc. Time 2	0.0 6000.0s	0.1s	10.0s	
	Bn-04	Deceleration Time 2	Bn-04=0010.0s Dec. Time 2	0.0 6000.0s	0.1s	10.0s	
Analog Frequency Command	Bn-05	Analog Frequency Cmd. Gain (Voltage)	Bn-05=0100.0% Freq. Cmd. Gain	0.0 1000.0%	0.1%	100.0%	2-4
	Bn-06	Analog Frequency Cmd. Bias (Voltage)	Bn-06=0000.0% Freq. Cmd. Bias	-100.0% 100.0%	0.1%	0.0%	
Torque Boost	Bn-07	Auto torque Boost Gain (Ineffective in energy-saving mode)	Bn-07=1.0 Auto_Boost Gain	0.0 2.0	0.1	1.0	2-4
A01 bias	Bn-08	Multi-Function Analog Output A01 Bias	Bn-08 =00.0% ~Output A01 Bias	-25.0%~+25.0%	0.1%	0.0%	2-4
A02 bias	Bn-09	Multi-Function Analog Output A02 Bias	Bn-09 =00.0% ~Output A02 Bias	-25.0%~+25.0%	0.1%	0.0%	2-5
	Bn-10	Monitor No. After power ON	Bn-10=1 Power On Contents	1 4	1	1	2-5
A01 Gain	Bn-11	Multi-Function Analog Output A01 Gain	Bn-11=1.00 Output A01 Gain	0.01 2.55	0.01	1.00	2-5
A02 Gain	Bn-12	Multi-Function Analog Output A02 Gain	Bn-12=1.00 Output A02 Gain	0.01 2.55	0.01	1.00	2-5
PID Control	Bn-13	PID Detection Gain	Bn-13=01.00 PID Det. Gain	0.01 10.00	0.01	1.00	2-5 2-6
	Bn-14	PID Proportional Gain	Bn-14=01.0 PID P-Gain	0.0 10.0	0.1	1.0	
	Bn-15	PID Integral Gain	Bn-15=010.0s PID I-Time	0.0 100.0s	0.1s	10.0s	
	Bn-16	PID Differential Time	Bn-16=0.00s PID D-Time	0.00 1.00s	0.01s	0.00s	
	Bn-17	PID Bias	Bn-17=000% PID Bias	0 109%* <sup>1</sup>	1%	0%	
PID Sleep Mode	Bn-18	PID sleep Frequency	Bn-18=000.00Hz PID Sleep Frequency	0.00 180.00Hz	0.01Hz	00.00Hz	2-6 2-7
	Bn-19	PID sleep/Wake-up Delay Time	Bn-19=000.0s PID Sleep Time	0.0 255.5Sec	0.1s	00.0s	
	Bn-20	PID Wake Up Frequency	Bn-20=60.00 Hz Wake_Up Frequency	0.00 180.00Hz	0.01Hz	60.00Hz	

\*1. Cn-04 is to be the 100% level.

Function	Parameter No.	Name	LCD Display (English)	Setting Range	Setting Unit	Factory Setting	Ref. Page
PID Display unit	Bn-21	PID Detected Value Display Bias	Bn-21=0.000 PID Det. DSPL Bias	-9.999~+9.999	0.001	0.000	2-8
	Bn-22	PID Detected Value Display Gain	Bn-22=0.000 PID Det. DSPL Gain	0.000~9.999	0.001	0.000	2-8
PA-PID Relay Card Control Function	Bn-23	Freq. Command Upper-Bound Delay Time	Bn-23=300s Up-Bound Delay Time	1~600sec	1s	300s	2-9
	Bn-24	Freq. Command Lower-Bound Delay Time	Bn-24=300s Low-Bound Delay Time	1~600sec	1s	300s	2-9
	Bn-25	MC ON/OFF Delay Time	Bn-25=1.00s MC ON/OFF Delay Time	0.10~2.00sec	0.01s	1.00s	2-9
	Bn-26	Pump ON/OFF Detection Level	Bn-26=00.0% PUMP ONOFF Det. Level	0.0~20.0%	0.1%	0.0%	2-9

**(1) Acceleration Time 1 (Bn-01)**

- Acceleration time 1 is enabled when the accel/decel time change command of multi-function terminal is "open", or the accel/decel time change function is not provided for the multifunction terminals. The acceleration time in which frequency reference goes from 0% to 100% is set in the units of 0.1 second.

**(2) Deceleration Time 1 (Bn-02)**

- Deceleration time 1 is enabled when the accel/decel time change command of multi-function terminals is "open", or the accel/decel time change function is not provided for the multifunction terminals. The deceleration time in which frequency reference goes from 100% to 0% is set in the units of 0.1 second.

**(3) Acceleration Time 2 (Bn-03)**

- Acceleration time 2 is enabled when the accel/decel time change command of multi-function terminals is "closed". The acceleration time in which frequency reference goes from 0% to 100% is set in the units of 0.1 second.

**(4) Deceleration Time 2 (Bn-04)**

- Deceleration time 2 is enabled when the accel/decel time change command of multi-function terminals is "closed". The deceleration time in which frequency reference goes from 100% to 0% is set in the units of 0.1 second.

**(5) Frequency Reference Gain (Bn-05)**

- The input level when frequency reference voltage is 10V is set in the units of 0.1%. Examples are shown in the below.

**(6) Frequency Reference Bias (Bn-06)**

- The input level when frequency reference voltage is 0V is set in the units of 0.1%.

< Example >

- ① Bn-05 = 50.0
- ② a: Bn-06 = 10.0  
b: Bn-06 = -10.0

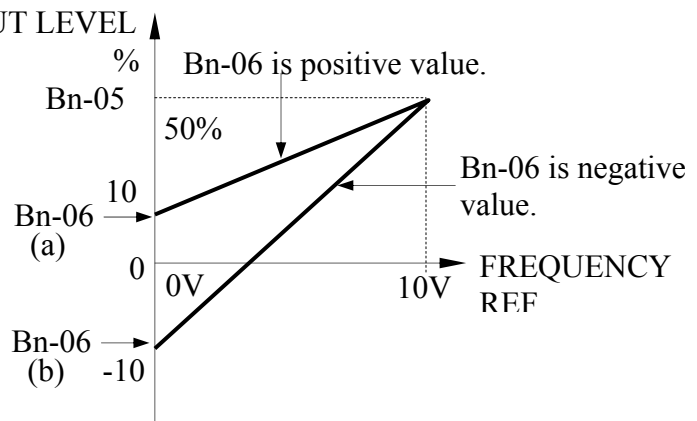
**(7) Torque Compensation Gain (Bn-07)**

- Torque compensation gain is set in the units of 0.1.

**(8) Multi-Function Analog Output A01 Bias(Bn-08)****(9) Multi-Function Analog Output A02 Bias(Bn-09)**

- The output voltage of Multi-function analog output A01 and A02 can be shifted up or down by Bn-08 and Bn-09 in the units of % individually.

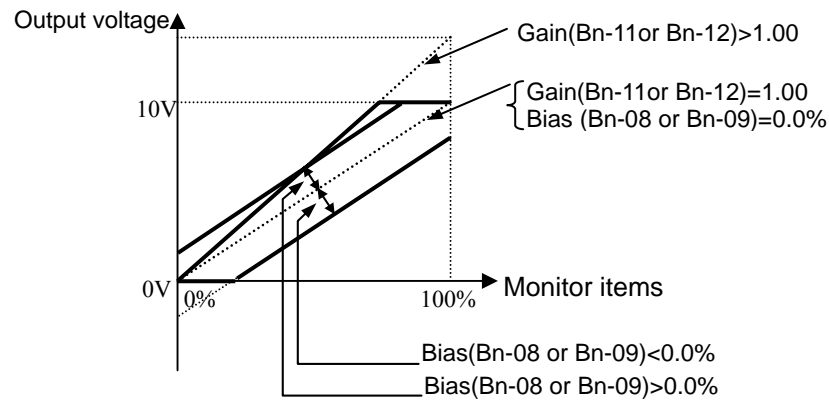

#### (10) Monitor No. after Turning On Power Supply (Bn-10)

- Data to be monitored after turning ON power supply is selected with constant No. in the form of Un-

- 1 Frequency reference (Bn-10=01 — Display: Freq. Cmd)
- 2 Output frequency (Bn-10=02 — Display: O/P Freq.)
- 3 Output current (Bn-10=03 — Display: O/P I)
- 4 PID detected value after display unit changing (Bn-10=04 — Display: PID Det. Value). ref to page 2-8.

#### (11) Multi-function Analog Output A01 Gain (Bn-11)

#### (12) Multi-function Analog Output A02 Gain (Bn-12)

- Multi-function Analog Output A01 and A02 can be set for their individual voltage level respectively.

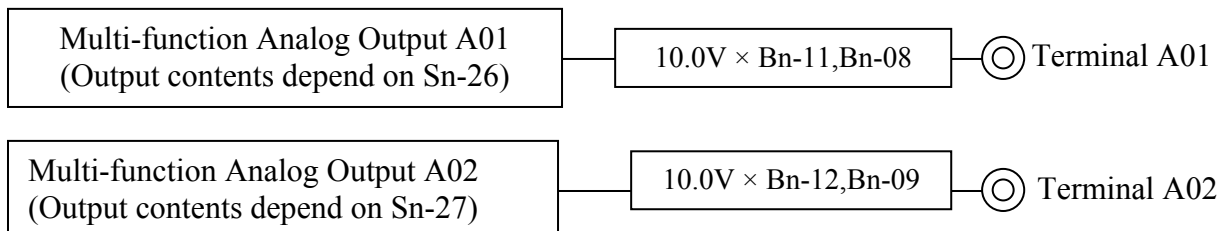

Fig.10 Diagram of Multi-function Analog Output

#### (13) Detected Value Adjusting Gain (Bn-13)

- The detected feedback value can be adjusted by multiplying adjusting gain Bn-13.

#### (14) Proportional Gain P (Bn-14)

- Output P is obtained by multiplying deviation value by proportional gain Bn-14. No P operation when Bn-14=0.0. Refer to page 2-6, the block diagram of PID control section.

#### (15) Integral Time I (Bn-15)

- Output I is an integral value of deviation. The additional value obtained at every 7 msec can be calculated by the following equation:

$$\left( \text{Deviation} \times \frac{7 \text{ msec}}{\text{Bn-15 set value}} \right)$$

No I operation when Bn-15 = 0.0 sec. Refer to page 2-6, the block diagram of PID control section.

**(16) Differential Time D (Bn-16)**

- Output D is obtained by multiplying variation by gain. That is, the output is obtained by multiplying the difference between the value before 7 msec of deviation and the current value by gain of (Bn-16 set value/7msec). No D operation when Bn-16= 0.00 sec. Refer to page 2-6, the block diagram of PID control section.

**(17) PID offset Adjustment (Bn-17)**

- Constant Bn-17 adjusts the PID control offset. If both the target value and the feedback value are set to zero, adjust the inverter's output frequency to zero.

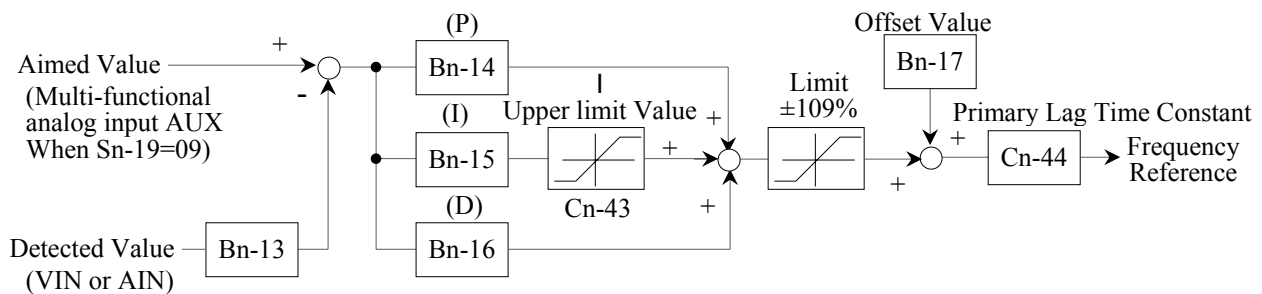
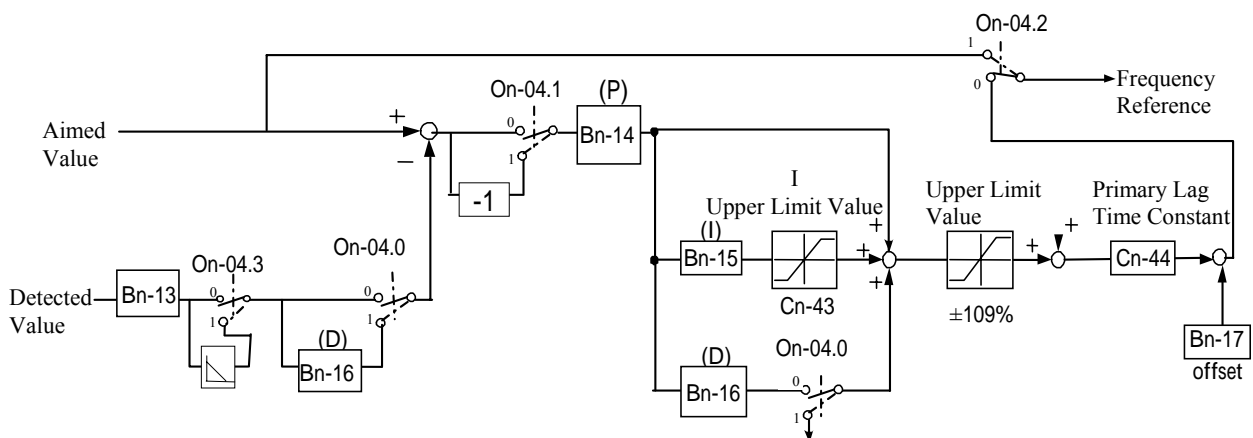
**Fig 11-(a) Block Diagram of PID Control Section****Fig 11-(b) Block Diagram of PID Control Section (After Ver. 04xx)**

Note 1) All PID calculations are executed every 7 msec.

2) The PID final outputs are all added.

**(18) PID Sleep Frequency (Bn-18)**

- Frequency level for activation of sleep function, When the PA output frequency drops below the PID sleep frequency set in parameter Bn-18, the PID sleep mode timer is started, The present output frequency ( $f_{out}$ ) will follow the frequency command ( $f_{CMD}$ ) until  $f_{min}$  is reached.

**(19) PID Sleep/Wake-up Delay Time (Bn-19)**

- This parameter enables the inverter to stop and start running the motor if the load on the motor is minimal.
- The time in Bn-19 starts when the output frequency ( $f_{out}$ ) drops below the frequency set in Bn-18 or when the frequency command ( $f_{CMD}$ ) exceeds the wake up frequency (Bn-20).
- At the sleep mode (i.e. when the output frequency  $f_{out}$  is below Sleep Frequency (Bn-18)), when the time set in the timer has expired, the inverter will ramp down the motor to stop. At the wake-up mode (i.e. when the frequency command  $f_{CMD}$  exceeds the wake up frequency (Bn-20)), when the time set in the timer has expired, the inverter will accelerate to frequency command. If the output frequency rises above the frequency set in Bn-18, or the frequency command drops below the set value in Bn-20, the timer is reset.

**(20) PID Wake Up Frequency (Bn-20)**

- Frequency level for deactivation of sleep function. When the frequency command ( $f_{CMD}$ ) exceeds the wake up frequency and after the time delay (set in Bn-19), the inverter restarts the motor.
- While the inverter has stopped the motor in sleep mode, the PID control function is still working. When the frequency command rises above the wake up frequency in Bn-20 and after the time delay (set in Bn-19), the inverter will restart the motor and the output frequency will ramp up to the frequency command.

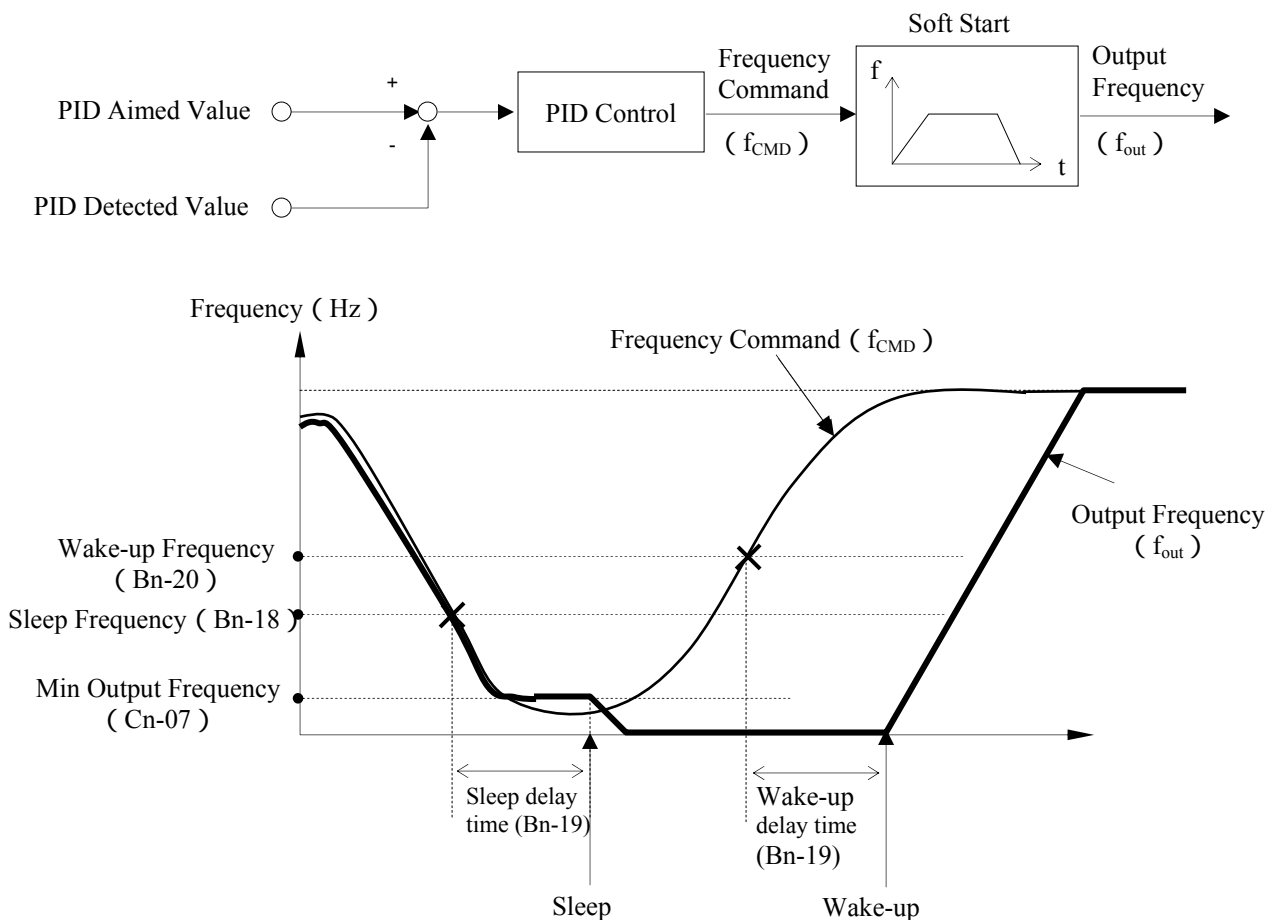

- \* 1. The PID sleep function is deactivation when PID control function disable (Sn-19 = 09)
- \* 2. When the timer runs out, the inverter will stop the motor depend on the stopping method set in Sn-04.
- \* 3. The sleep function is not active in JOG mode.
- \* 4. Sleep mode makes it possible to stop the motor when it is running at low speed and this has almost no load. If consumption in the system goes back up, the inverter will start the motor and supply the power supply. Energy saving can be saved with this function, since the motor is only in operative when the system needs it.

### (21) PID Detected Value Display Bias (Bn-21)

### (22) PID Detected Value Display Gain (Bn-22)

- The PID detected value can be input from control terminal VIN (0~10V) or AIN (4-20mA), the detected value is the addition of VIN and AIN, when the detected feedback signal is input from VIN and AIN terminal simultaneously.
- The multi-function analog output can be set to monitor the PID detected value (When Sn-26=09 or Sn-27=09)
- The PID detected value can be monitored by the monitoring parameter Un-21, and the display unit can be set by Bn-21 and Bn-22 (eg. 0~10V or 4-20mA detected value can be set as pressure signal unit, using Bn-21 to set the equivalent pressure value for 0V or 4mA PID detected value and Bn-22 to set the equivalent pressure value for 10V or 20mA PID detected value).
- The PID detected value also can be monitored by digital operator after turning on power supply. (When Bn-10=04).

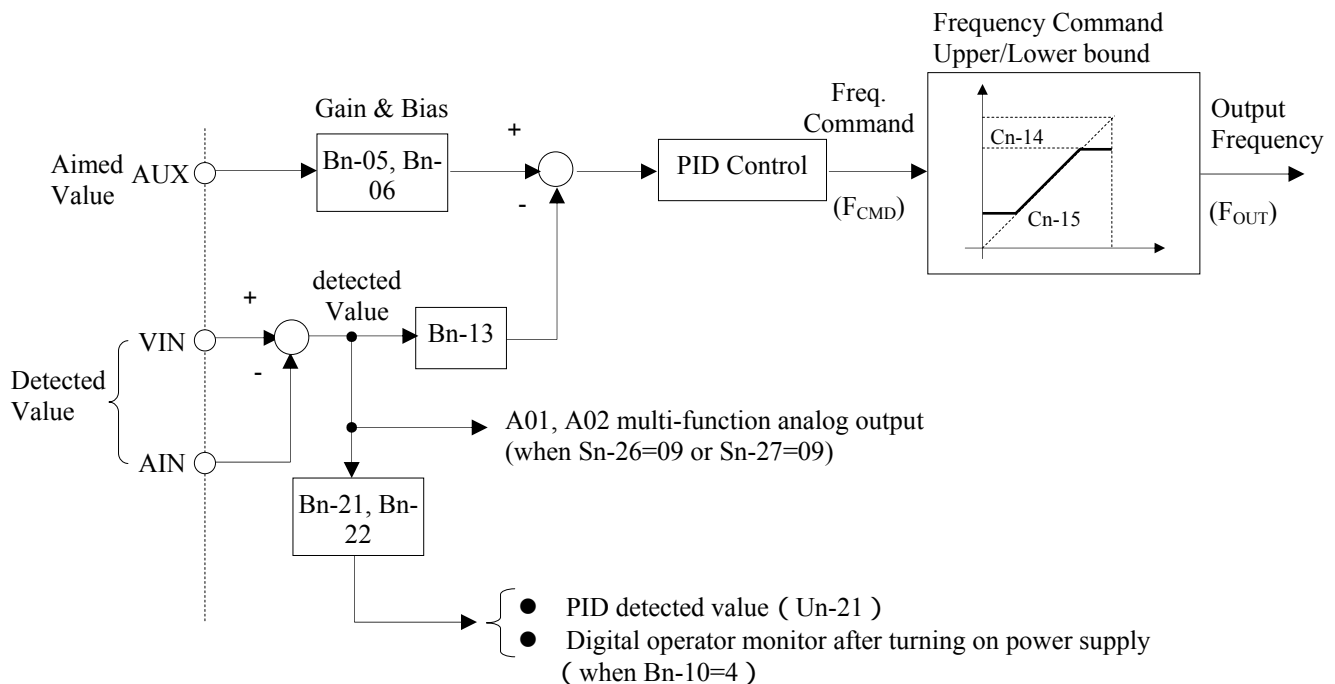

**(23) Frequency Command Upper-Bound Delay Time (Bn-23)**

- The PA-PID option card application parameter. If the inverter output frequency after PID controlling exceeds the frequency command upper bound (the Cn-14 set value), the relay output on PA-PID card will active to increase the pump numbers when the delay time set by Bn-23 has expired.
- The set value of Bn-23 depends on the pressure response of water supply system, the set value is the smaller the better as long as the system pressure cannot vibrate.

**(24) Frequency Command Lower-Bound Delay Time (Bn-24)**

- The PA-PID option card application parameter. If the inverter output frequency after PID controlling drops below the frequency command lower bound (the Cn-15 set value), the relay output on PA-PID card will active to decrease the pump numbers when the delay time set by Bn-24 has expired.
- The set value of Bn-24 depends on the pressure response of water supply system, the set value is as small as better if the system pressure cannot vibrate.

Please refer to “PA-PID instruction manual”.

**(25) MC ON/OFF Delay Time (Bn-25)**

- The PA-PID option card application parameter. Please refer to “PA-PID instruction manual”.
- When switching one motor (or pump) driving by inverter to ac power source or vice versa set the MC ON/OFF delay time (set value of Bn-25) to avoid the inverter output and ac power source being short-circuited due to the different operation delay time of MC1 and MC2.
- The delay time (Bn-25 set value) must be longer than the time from the MC ON/OFF controlled signal output from inverter until the external MC operation.
- Generally, the MC operation time from OFF to ON is longer than ON to OFF, set the delay time according to the longer one.

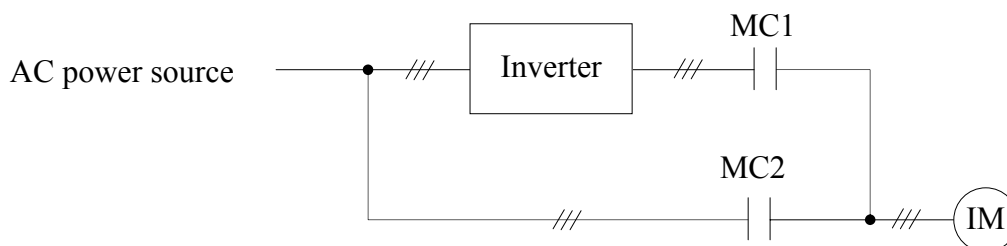
**(26) Pump ON/OFF Detection Level (Bn-26)**

- The PA-PID option card application parameter. Please refer to “PA-PID instruction manual”.
- The set value of Bn-26 is the deviation level of PID aimed value and PID detected value when using PA-PID option card to increase or reduce the pump numbers.
- Set the pump ON/OFF detection level in units of 0.1%. If the value is set to 0.0%, when output frequency reaches the frequency upper bound (the set value of Cn-14) increases the pump numbers immediately, and when output frequency drops to the frequency lower bound (the set value of Cn-15) decreases the pump numbers immediately.

## 2.3 Control Parameters Cn-

Function	Parameter No.	Name	LCD Display (English)	Setting Range	Setting Unit	Factory Setting	Ref. Page
V/F Pattern Setting	Cn-01	Input Voltage	Cn-01=220.0V Input Voltage	150 255.0V* <sup>1</sup>	0.1V	220.0V* <sup>2</sup>	2-13 2-32
	Cn-02	Max. Output Frequency	Cn-02=060.0Hz Max. O/P Freq.	50.0 180.0Hz	0.1Hz	60.0Hz* <sup>7</sup>	
	Cn-03	Max. Output Voltage	Cn-03=220.0V Max. Voltage	0.1 255.0V* <sup>1</sup>	0.1V	220.0V* <sup>2,*7</sup>	
	Cn-04	Max. Voltage Frequency	Cn-04=060.0Hz Max. Volt. Frequency	0.1 180.0Hz	0.1Hz	60.0Hz* <sup>7</sup>	
	Cn-05	Middle Output Frequency	Cn-05=030.0Hz Middle O/P Freq.	0.1 180.0Hz	0.1Hz	30.0Hz* <sup>7</sup>	
	Cn-06	Voltage At Middle Output Frequency	Cn-06=055.0V Middle Voltage	0.1 255.0V* <sup>2</sup>	0.1V	55.0V* <sup>1,*7</sup>	
	Cn-07	Min Output Frequency	Cn-07=001.5Hz Min O/P Freq.	0.1 180.0Hz	0.1Hz	1.5Hz* <sup>7</sup>	
	Cn-08	Voltage At Min. Output Frequency	Cn-08=008.0V Min. Voltage	0.1 255.0V* <sup>2</sup>	0.1V	8.0V* <sup>1,*7</sup>	
Current Base	Cn-09	Motor Rated Current	Cn-09=031.0A Motor Rated I	* 3	0.1A	31A* <sup>4</sup>	2-13
DC Braking Function	Cn-10	DC Injection Braking Starting Frequency	Cn-10=01.5Hz DC Braking Start F	0.1 10.0Hz	0.1Hz	1.5Hz* <sup>7</sup>	2-13 2-14
	Cn-11	DC Braking Current	Cn-11=050% DC Braking Current	0 100%	1%	50%	
	Cn-12	DC Injection Braking Time At Stop	Cn-12=00.0s DC Braking Stop Time	0.0 25.5s	0.1s	0.0s	
	Cn-13	DC Injection Braking Time At Start	Cn-13=00.0s DC Braking Start T	0.0 25.5s	0.1s	0.0s	
Frequency Limit	Cn-14	Frequency Command Upper Bound	Cn-14=100% Freq. Cmd. Up Bound	0 109%	1%	100%	2-14
	Cn-15	Frequency Command Lower Bound	Cn-15=000% Freq. Cmd. Low Bound	0 109%	1%	0%	
Frequency Jump	Cn-16	Frequency Jump Point 1	Cn-16=000.0Hz Frequency Jump 1	0.0 180.0Hz	0.1Hz	0.0Hz	2-15
	Cn-17	Frequency Jump Point 2	Cn-17=0.0Hz Frequency Jump 2	0.0 180.0Hz	0.1Hz	0.0Hz	
	Cn-18	Frequency Jump Point 3	Cn-18=0.0Hz Frequency Jump 3	0.0 180.0Hz	0.1Hz	0.0Hz	
	Cn-19	Jump Frequency Width	Cn-19=01.0Hz Freq. Jump Width	0.0 25.5Hz	0.1Hz	1.0Hz	
Display Unit	Cn-20	Digital Operator Display Unit	Cn-20=00000 Operator Disp. Unit	0 39999	1	0	2-15
Agreed Speed Detection	Cn-21	Frequency Agree Detection Level	Cn-21=000.0Hz F Agree Det. Level	0.0 180.0Hz	0.1Hz	0.0Hz	2-16
	Cn-22	Frequency Agree Detection Width	Cn-22=02.0Hz F Agree Det. Width	0.1 25.5Hz	0.1Hz	2.0Hz	
Carrier Frequency	Cn-23	Carrier Frequency Upper Limit	Cn-23=6.0KHz Carry-Freq Up Bound	0.4 6.0KHz* <sup>5</sup>	0.1KHz	6.0KHz* <sup>5</sup>	2-17
	Cn-24	Carrier Frequency Lower Limit	Cn-24=6.0KHz Carry-Freq Low Bound	0.4 6.0KHz* <sup>5</sup>	0.1KHz	6.0KHz* <sup>5</sup>	
	Cn-25	Carrier Frequency proportion Gain	Cn-25=00 Carry-Freq P_ Gain	0 99	1	0* <sup>5</sup>	

Function	Parameter No.	Name	LCD Display (English)	Setting Range	Setting Unit	Factory Setting	Ref. Page
OVER-Torque Detection	Cn-26	Overtorque Detection Level	Cn-26=160% Over Tq. Det. Level	30 200%	1%	160%	2-17
	Cn-27	Overtorque Detection Time	Cn-27=00.1s Over Tq. Det. Time	0.0 25.5s	0.1s	0.1s	
Stall Prevention	Cn-28	Stall Prevention Level During Acceleration	Cn-28=150% ACC. Stall	30 200%	1%	150%	2-17
	Cn-29	Not used	Cn-29=000 Reserved	00 000	-	-	-
	Cn-30	Stall Prevention Level During Running	Cn-30=130% Running Stall	30 200%	1%	130%	2-17
Communication Fault	Cn-31	Communication Fault Detection Time	Cn-31=01.0s Comm. Flt. Det. Time	0.1 25.5s	0.1s	1s	2-18
Frequency Detection	Cn-32	Frequency Detection 1 Level	Cn-32=000.0Hz Freq.Det. 1 Level	0.0~180.0Hz	0.1Hz	0.0Hz	2-18
	Cn-33	Frequency Detection 2 Level	Cn-33=000.0Hz Freq.Det. 2 Level	0.0~180.0Hz	0.1Hz	0.0Hz	2-18
-	Cn-34	Not used	Cn-34=0 Reserved	0 0	-	-	-
	Cn-35	Not used	Cn-35=0.0 Reserved	0.0 0.0	-	-	-
Fault Retry	Cn-36	Number of Auto Reatart Attempt	Cn-36=00 Retry Times	0 10	1	0	2-19 2-24
Ride-thru Time	Cn-37	Power Loss Ride-thru Time	Cn-37=2.0s Ride-Thru Time	0 2.0s	0.1s	2.0s*4	2-19
Speed Search Control	Cn-38	Speed Search Detection Level	Cn-38=150% SP_Search Level	0 200%	1%	150%	2-20
	Cn-39	Speed Search Time	Cn-39=02.0s SP_Search Time	0.1 25.5s	0.1s	2.0s	
	Cn-40	Min. Baseblock Time	Cn-40=1.0s Min. B.B. Time	0.5 5.0s	0.1s	1.0s*4	
	Cn-41	V/F Curve in Speed Search	Cn-41=100% SP_Search V/F Curve	10 100%	1%	100%	
	Cn-42	Voltage Recovery Time	Cn-42=0.3s Voltage Recovery	0.1 5.0s	0.1s	0.3s	
PID Control	Cn-43	PID Integral Upper Bound	Cn-43=100% PID I-Upper	0 109%	1%	100%	2-21
	Cn-44	PID Primary Delay Time Constant	Cn-44=0.0s PID Filter	0.0 2.5s	0.1s	0.0s	
Energy-Saving Voltage Limit	Cn-45	Energy-Saving Volt. Upper Limit (60Hz)	Cn-45=120% Level 60 Hz	0 120%	1%	120%	2-21
	Cn-46	Energy-Saving Volt. Upper Limit (6Hz)	Cn-46=16% Level 6 Hz	0 25%	1%	16%	
	Cn-47	Energy-Saving Volt. Lower Limit (60Hz)	Cn-47=050% Level 60 Hz	0 100%	1%	50%	
	Cn-48	Energy-Saving Volt. Lower Limit (6Hz)	Cn-48=12% Level 6 Hz	0 25%	1%	12%	

Function	Parameter No.	Name	LCD Display (English)	Setting Range	Setting Unit	Factory Setting	Ref. Page
Energy-Saving Tuning operation	Cn-49	Tuning Operation Voltage Limit	Cn-49=00% Sav. Tuning V_Limit	0 20%	1%	0%	2-22
	Cn-50	Tuning Operation Control Cycle	Cn-50=01.0s Sav. Tuning period	0.1 10.0s	0.1s	1.0s	
	Cn-51	Tuning Operation Volt. Step (100% output Volt)	Cn-51=00.5% O/P Volt. 100%	0.1 10.0%	0.1%	0.5%	
	Cn-52	Tuning Operation Volt. Step (5% output Volt)	Cn-52=00.2% O/P Volt. 5%	0.1 10.0%	0.1%	0.2%	
-	Cn-53	Not used	Cn-53=00.000 Reserved	00.000 00.000	-	-	-
	Cn-54	Not used	Cn-54=00.000 Reserved	00.000 00.000	-	-	-
	Cn-55	Not used	Cn-55=00.000 Reserved	00.000 00.000	-	-	-
	Cn-56	Not used	Cn-56=00.000 Reserved	00.000 00.000	-	-	-
	Cn-57	Not used	Cn-57=000.00 Reserved	000.00 000.00	-	-	-
Energy-Saving Coefficient K2	Cn-58	Energy-Saving Coefficient K2 (60Hz)	Cn-58=115.74* <sup>6</sup> Eng. Saving Coeff	0.00 655.35	0.01	115.74* <sup>6</sup>	2-22
	Cn-59	Energy-Saving Coefficient Reduction ratio (6Hz)	Cn-59=100% K2 Reduce Ratio	50 100%	1%	100%	2-23
	Cn-60	Motor Code	Cn-60=29* <sup>4</sup> Reserved	00 FF	-	29* <sup>8</sup>	2-23
-	Cn-61	Not used	Cn-61=000 Reserved	000~000	-	-	-
Retry time	Cn-62	Auto Restart Time Interval	Cn-62=00s Retry time	0 20s	1s	0s	2-24
Motor Overheat time	Cn-63	Motor Overheat protection time	Cn-63=060s Motor OH time	1 300s	1s	60s	2-24

\*1 For 220V class. × 2 for 440V class.

\*2 For 220V class. × 2 for 440V class.

\*3 Setting range becomes 10 to 200% of inverter rated current. The factory setting base on TECO AEEF standard 4 poles motor, 220V/60Hz, 440V/60Hz.

\*4 Factory settings differ depending on inverter capacity (Sn-01 set value).  
This example shows combination of TECO standard motor 440V 60Hz 25HP (18.5KW).  
(Refer to the table on page 69)

At setting Sn-01, the set value changes to the factory setting. For any application other than TECO standard motors, set the value shown on the nameplate of the motor.

\*5 Factory setting and setting, range differ depending on inverter capacity (Sn-01 set value).

\*6 Differs depending on Cn-60 set value.

\*7 Factory setting differ depending on V/F curve selection (Sn-02).

\*8 The same value as Sn-01 is set.

**(1) Input voltage (Cn-01)**

- Set inverter input voltage. (in the unit of 0.1V).

**(2) V/f constant (Cn-02 to Cn-08)**

- Set inverter output frequency/voltage characteristics (V/f characteristics.)

**(a) Changing V/f characteristics**

Sn-02 = 0 to 3 : V/f characteristics determined by set value. settings of CN-02 to Cn-08 cannot be changed.

Sn-02 = 4 : Any V/f characteristic can be obtained by the set values of constants Cn-02 ~ Cn-08

(b) Voltage values (Cn-03, Cn-06, Cn-08) displayed in the operator depend on the set value of Sn-02 (V/f selection)

(c) Sn-02 = 4 : The set value is displayed.

(d) When V/F characteristics are a straight line, the same value as Cn-07 is set in Cn-05. The set value of Cn-06 is disregarded.

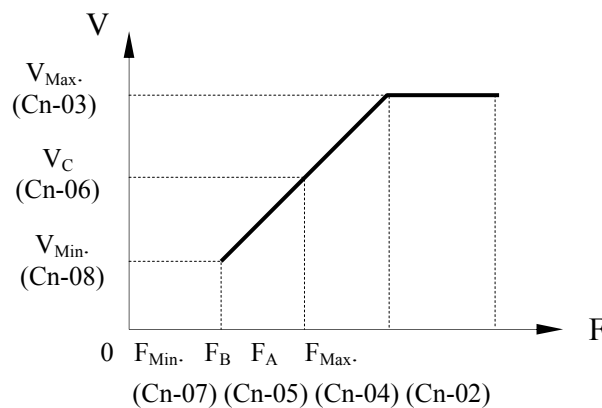

Notes:

1. The maximum output voltage is limited by input voltage.
2. When the set values of Cn-02 to Cn-08 do not satisfy the following conditions, a setting error occurs and Invalid V/F OPE10 alarm is displayed.  
The set value is checked at power ON and switching from PRG mode to DRIVE mode.  
 $F_{MAX} \cdot F_A > F_B \cdot F_{Min}$ .

**(3) Motor rated current (Cn-09)**

- Set motor rated current by the electronic thermal function in units of 0.1 A for motor overload protection. The range of setting is 10% to 200% of inverter rated current. When the 1st digit of Sn-14 is 1, the electronic thermal function is disabled and the motor is not protected from overheating due to overload.

**(4) DC injection braking starting frequency (Cn-10)**

- Set a frequency for starting DC braking at deceleration stop in units of 0.1 Hz. When a set value is not greater than Cn-07 (minimum output frequency), DC braking is started with the minimum output frequency.

**(5) DC braking current (Cn-11)**

- Set DC braking current in units of 1%. Inverter rated current is 100%.

**(6) DC injection braking time at stop (Cn-12)**

- Set the duration of DC braking at stop in units of 0.1 second.
- When a set value is 0, DC braking is not performed, and inverter output is shut off at the start of DC braking.

**(7) DC injection braking time at start (Cn-13)**

- Set the duration of DC braking at starting in units of 0.1 second.
- When a set value is 0, DC braking is not performed, and acceleration begins with the minimum output frequency.

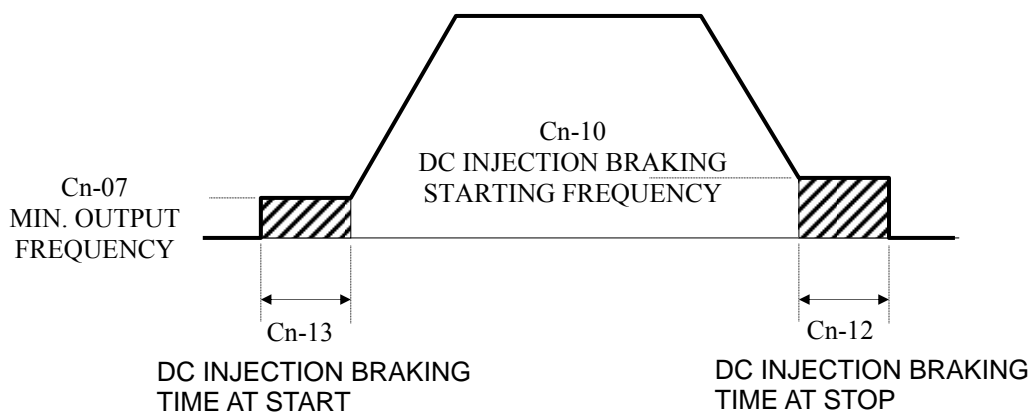
**(8) Frequency command upper bound (Cn-14)**

- Set the upper limit of frequency reference in units of 1%. Cn-02.(maximum frequency) is regarded as 100%.

**(9) Frequency command lower bound (Cn-15)**

- Set the lower limit of frequency reference in units of 1%. Cn-02 (maximum frequency) is regarded as 100%. When the run command is input with frequency reference of 0, acceleration continues from the minimum frequency to the lower frequency reference limit, and operation continues in the lower frequency reference limit.

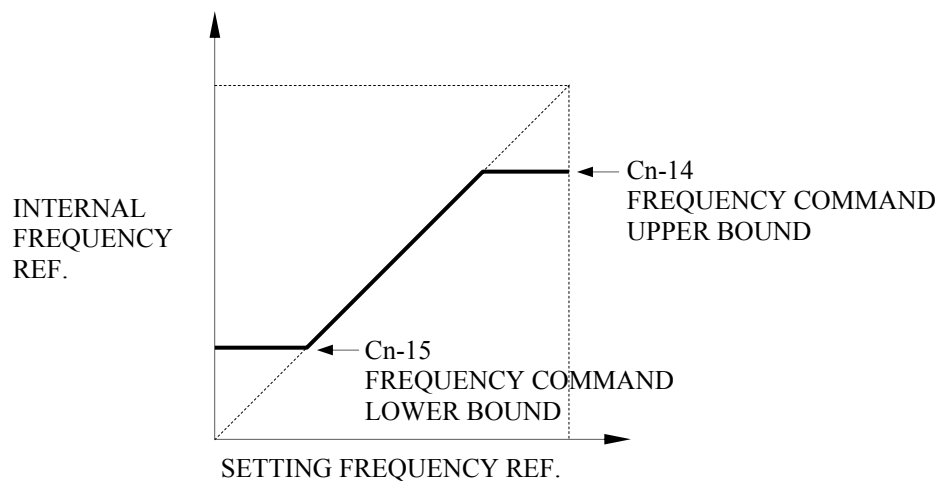

**(10) Setting prohibit frequencies 1 to 3 (Cn-16 to Cn-18)**

- Set a setting prohibit frequency in units of 0.1 Hz. A set value of 0.0 Hz disables this function.
- If the setting prohibit frequency ranges overlap, set setting prohibit frequency 1 to 3 as shown below:

Cn-18    Cn-17    Cn-16

**(11) Setting prohibit frequency range (Cn-19)**

- Set the range of setting prohibit frequency in units of 0.1 Hz. The range of the setting prohibit frequency is determined as follows, depending on combinations with Cn-16 to Cn-18.

Cn-16 to Cn-18 - Cn-19    the range of the setting prohibit frequency    Cn-16 to Cn-18 + Cn-19

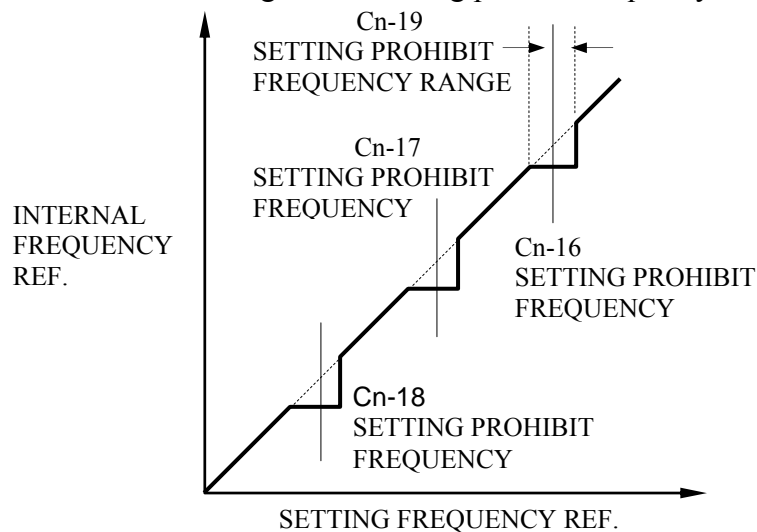

Note: Constant-speed operation is prohibited in the setting prohibit frequency range. Output frequency does not jump during acceleration or deceleration, which is performed smoothly.

**(12) Digital Operator Display Unit (Cn-20)**

- The setting unit of frequency references 1 to 8 and jog frequency reference depends on the set value of operator display mode (Cn-20) as follows:

Cn-20	Setting / Reading Unit
0	Units of 0.01 Hz
1	Units of 0.01%
2 to 39	Set in the units of r / min (0 to 39999). r / min = 120 x frequency reference (Hz) / Cn-20 (Set the number of motor poles in Cn-20)
40 to 39999	The position of decimal point is set by the value of the 5th digit of Cn-20. Value of 5th digit = 0: Displayed as XXXX Value of 5th digit = 1: Displayed as XXX.X Value of 5th digit = 2: Displayed as XX.XX Value of 5th digit = 3: displayed as X.XXX A set value of 100% frequency is determined by the 1st digit to 4th digit of Cn-20. Example 1: When the set value of 100% speed is 200.0, Cn-20 = 12000 is set. 100% speed is displayed as 200.0 at Cn-29 = 12000. 60% speed is displayed as 120.0 Example 2: When the set value of 100% speed is 65.00, Cn-20 = 26500 is set. 60% speed is displayed as 39.00 at Cn-20 = 26500.

**(13) Frequency agree detection level (Cn-21)**

- Set an agreed frequency point in units of 0.1 Hz.

**(14) Frequency agree detection width (Cn-22)**

- Set an agreed frequency detection width in units of 0.1 Hz. The relation with multi-function contact output are shown in the four figures below (a) , (b) and the frequency detection 1,2(Cn-32,Cn-33) in page 2-18 .

(a) Agreed frequency (set value of multi-function contact output Sn-20~22= 2)

- This is "closed" when output frequency is within the detection width shown in the following figure.

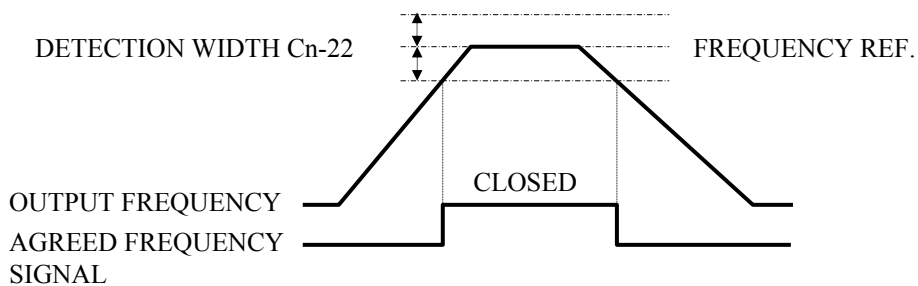

(Frequency ref. - Cn-22)    Output frequency    (Frequency ref. + Cn-22)

Cn-21: Agreed frequency point

Cn-22: Agreed frequency detection width

(b) Agreed frequency (set value of multi-function contact output Sn-20~22= 3)

- This is "closed" when acceleration or deceleration is completed and output frequency is within the detection width shown in the figure below.

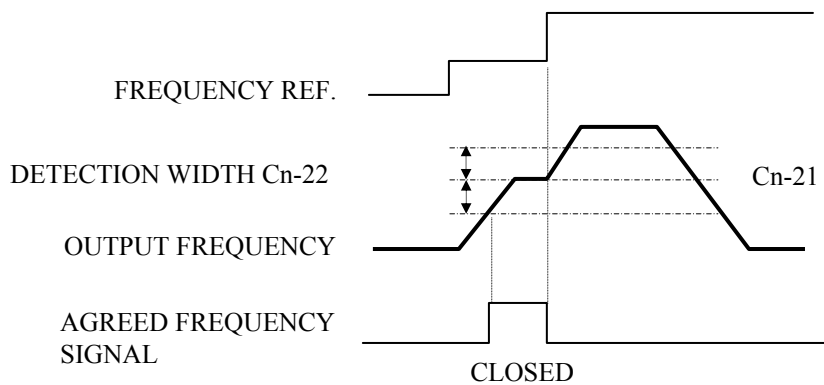

(Cn-21 - Cn-22)    Output frequency    (Cn-21 + Cn-22)

Cn-21: Agreed frequency point

Cn-22: Agreed frequency detection width

**(15) Carrier frequency upper/lower limit, proportion gain (Cn-23 to Cn-25)**

- The relationship between output frequency and carrier frequency is determined as follows from the set values of Cn-23 to Cn-25.
  - (a) For constant carrier frequency (set value of Cn-23):
    - Set 0 in Cn-25 and set the same value in Cn-23 and Cn-24.
  - (b) For carrier frequency: Carrier frequency changes according to Cn-23 to 25 set values and output frequency as shown below.

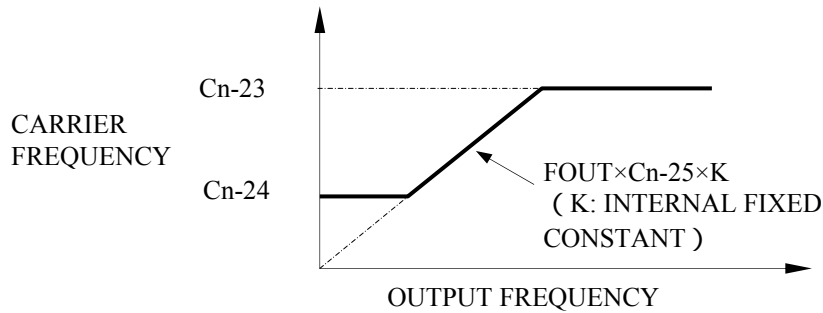

Invalid Fc (OPE11) is displayed in the following cases:

- 1 Cn-25 > 6 and Cn-24 > Cn-23
- 2 Cn-23 > 5kHz and Cn-24 > 5 kHz

**(16) Overtorque detection level (Cn-26)**

- Set overtorque level in units of 1%. Inverter rated current is regarded as 100%.

**(17) Overtorque detection time (Cn-27)**

- Set overtorque detection time in units of 0.1 second.

**(18) Stall prevention level during acceleration (Cn-28)**

- Set stall prevention level during acceleration in units of 1%. Inverter rated current is regarded as 100%.

**(19) Stall prevention level during running (Cn-30)**

- Set a proportion as a stall prevention level during running in units of 1%. Inverter rated current is regarded as 100%
- Stall prevention during running starts deceleration when the output current reaches 100 ms greater than the setting value of Cn-30 (stall prevention level during running) during agreed frequency. The inverter decelerates as long as the output current exceeds the setting value of Cn-30 (stall prevention level during-running). When the output current goes below the setting value, the inverter reaccelerates. The deceleration time selected in the 4th digit of Sn-10 is taken.
- Even during stall prevention while running, stall prevention during deceleration and stall prevention during acceleration are enabled.

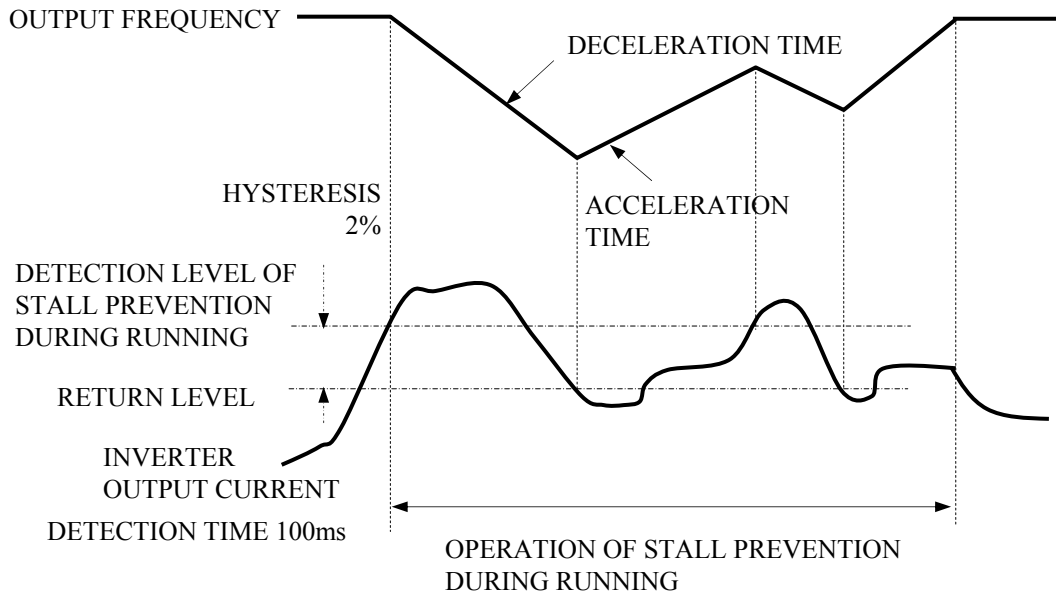

### (20) Communication fault detection time (Cn-31)

- Please refer to “7300PA MODBUS/PROFIBUS application manual”.

### (21) Frequency detection 1 level (Cn-32)

- When the setting value of multi-function contact output (Sn-20~22)=4, this contact is "closed" when output frequency is equal to or less than Cn-32, as shown in the figure below.

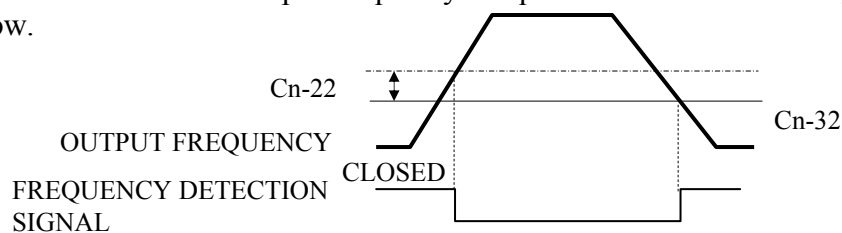

Output frequency Cn-32

Cn-32: Frequency detection 1 level

Cn-22: Agreed frequency detection width

### (22) Frequency detection 2 level (Cn-33)

- When the setting value of multi-function contact output (Sn-20~22)=5, this contact is "closed" when output frequency is equal to or more than Cn-33, as shown in the figure below.

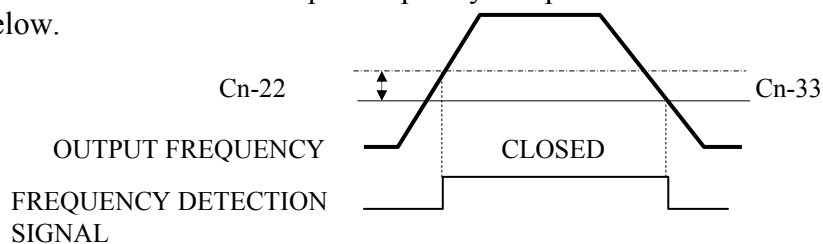

Output frequency Cn-33

Cn-33: Frequency detection 2 level

Cn-22: Agreed frequency detection width

**(23) Number of auto restart attempt (Cn-36)**

- Set the number of auto reset/restart operation. Setting of zero causes no auto reset/restart operation.
- Each time one of OC, OV, OL1, OL2, OL3, OH, UV1 (OC, GF, OV, rr or UV1) fault occurs, one is added to the number of auto reset/restart operation, and auto reset/restart operation is performed according to the following procedure.
- However, auto reset/restart operation is not performed in the following case:
  - 1 When operation not continued at momentary power loss (3rd digit of Sn-11=0) is specified, UV1 fault is not automatically reset.
  - 2 When OC or OV fault occurs due to external fault during deceleration stop or DC injection braking stop, inverter output is shut off.
- The number of auto reset/restart operation is cleared to zero when:
  - 1 No fault occurs for 10 minutes or more.
  - 2 A fault reset signal is input from control circuit terminals or digital operator.
- Auto reset/restart operation
  - 1 When a fault is detected, inverter output is shut off for the minimum baseblock time (Cn-40). During shut off of inverter output, a fault occurring in the operator is displayed.
  - 2 When the minimum baseblock time (Cn-40) elapses, the fault is automatically reset, and speed search operation is performed with the output frequency at the time of the fault.
  - 3 When the total number of fault exceeds the number of auto restart attempts (Cn-36), automatic reset is not performed and inverter output is shut off. At this time, fault contact output is output.

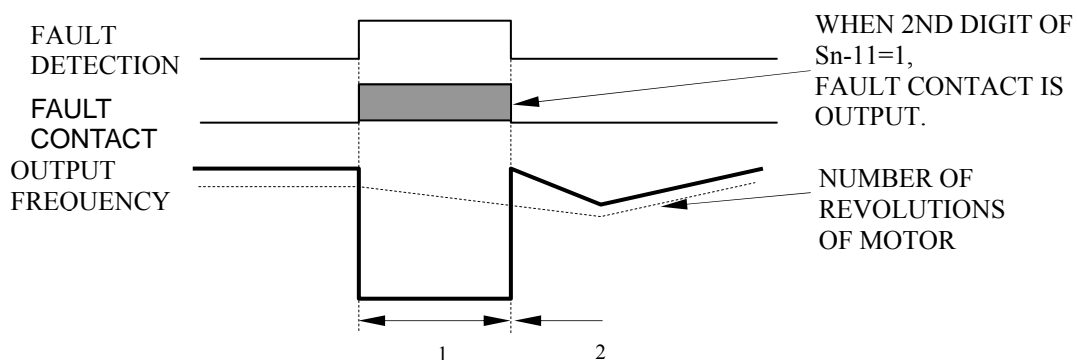
**(24) Power loss ride-thru time (Cn-37)**

- Set in units of 0.1 second. The initial value depends on the inverter capacity

**(25) Speed search detection level (Cn-38)**

- When inverter output current immediately after power recovery is larger than the set value of Cn-38, speed search operation is started. When inverter output current is smaller than the set value of Cn-38, the frequency is interpreted as a speed synchronization point and acceleration or deceleration is performed again up to a specified frequency.

**(26) Speed search time (Cn-39)**

- Set deceleration time during speed search in units of 0.1 second. Setting of 0.0 second causes no speed search.

**(27) Minimum baseblock time (Cn-40)**

- On detecting momentary power loss, the inverter shuts off output and maintains the baseblock state for a given time. Set in Cn-40 the time when residual voltage is expected to be almost zero.
- When momentary power loss time is longer than the minimum baseblock time, speed search operation is started immediately after power recovery.

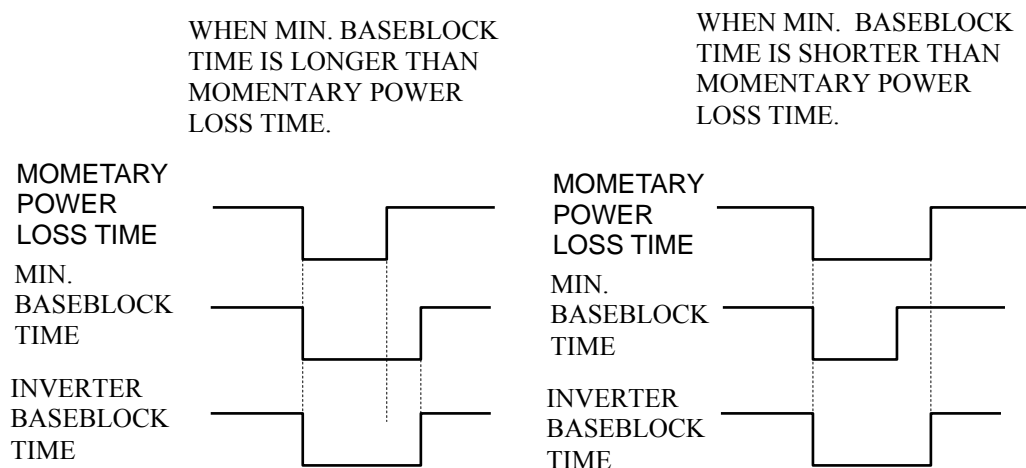
**(28) V/f speed search (Cn-41)**

- To ensure that a fault such as OC does not occur during speed search operation, V/f must be reduced during speed search operation, as compared with that during normal operation. Set V/f during speed search as follows by the set value of Cn-41:  $V/f \text{ during speed search} = V/f \text{ at normal operation} \times Cn-41$

**(29) Voltage recovery time (Cn-42)**

- Set in Cn-42 the time between completion of speed search operation and return to V/f at normal operation. The set of voltage recovery time is set as follows:  
 220V Class: Time required to raise voltage from 0 to 220V  
 440V Class: Time required to raise voltage from 0 to 440V

**(30) PID integral upper bound (Cn-43)**

- The upper limit value of value I can be set by Cn-43. To increase the control capability by integration, increase the value of Cn-43. Reduce the setting of Cn-43 if there is a risk of load damage, or of the motor going out of step, by the inverter's response when the load suddenly changes. Set this constant as a percentage of the maximum output frequency, with the maximum frequency taken as 100%. If the control system vibrates and vibration cannot be eliminated even by adjusting the integral time (bn-15) or primary lag time constant (Cn-44), decrease the value of Cn-43, but if the setting of Cn-43 is reduced too much, the target value and the feedback value will not match. Refer to page 45, the block diagram of PID control section.

**(31) PID primary delay time constant (Cn-44)**

- Constant Cn-44 is the low-pass filter setting for PID control outputs, there is normally no need to change the setting, if the viscous friction of the mechanical system is high, or if the rigidity is low, causing the mechanical system to oscillate, increase the setting so that it is higher than the oscillation frequency period. This will decrease the responsiveness, but it will prevent oscillation. Refer to page 45, the block diagram of PID control section.

**(32) Energy-saving voltage limit (Cn-45 to Cn-48)**

- The upper and lower limits of output voltage are set. If the voltage reference value calculated in the energy-saving mode exceeds the upper or lower limit value, this upper or lower limit value is output as voltage reference value.
- The upper limit value is set in order to prevent over excitation at low frequency and the lower limit value is set in order to prevent stalling at a light load. Limit voltage values obtained at 6Hz and 60Hz are set: for any limit value other than at 6Hz and 60Hz, the values calculated by linear interpolation of these values. Setting is made in the units of % of rated voltage.

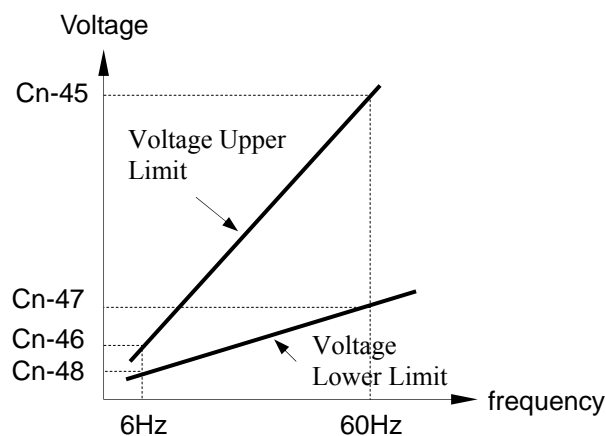

**(33) Energy-saving tuning operation (Cn-49 to Cn-52)**

- In the energy-saving mode (Sn-09 = X1XX) the optimum voltage is calculated according to load power and the voltage is supplied to the load. However, since the setting motor constants are different depending on temperature variation or use of other manufactures' -motors, the optimum voltage is not always output. At tuning operation, operation is controlled so that the optimum operating status can be obtained by fine adjustment of voltage.

**(a) Tuning Operation voltage Limit (Cn-49)**

- Limits the range where voltage is controlled by tuning operation. Setting is made in the units of % of rated voltage. By setting this value to 0, tuning operation is not performed.

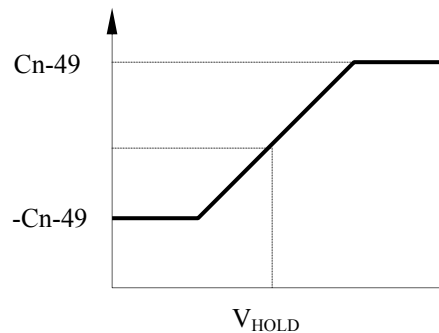
**(b) Tuning Operation Control Cycle (Cn-50)**

- Sets the control cycle of tuning operation.

**(c) Tuning Operation voltage Step (Cn-51, 52)**

- Sets voltage variation width of one tuning operation cycle. Setting is made in the units of % of rated voltage. By increasing this value, rotation speed variation becomes larger. This voltage variation width is set at tuning starting voltage 100% and 5%. With the other voltage value, voltage variation width obtained by linear interpolation is set.

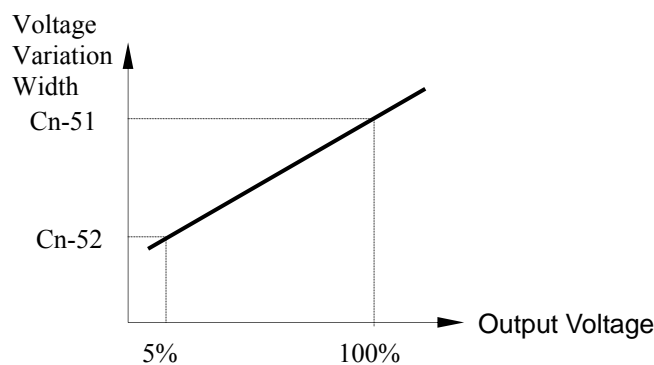
**(34) Energy-saving coefficient K2 (Cn-58)**

- Voltage at which the motor efficient will be the maximum is calculated by using this coefficient at operation in the energy-saving mode, and the calculated value is to be voltage reference. This value is already set to the value of a TECO motor as the initial value. By increasing the energy-saving coefficient, output voltage becomes larger.

**(35) Energy-saving coefficient reduction ratio (Cn-59)**

- In order to prevent over excitation in the low frequency area, this constant reduces output voltage at low frequency. Set in the reduction ratio at 6Hz. According, to this value, output voltage is reduced with the reduction ratio (Cn-59) when output voltage of 15Hz or less is 6Hz or with the reduction ratio obtained by linear interpolation of reduction ratio (100%) at 15Hz.

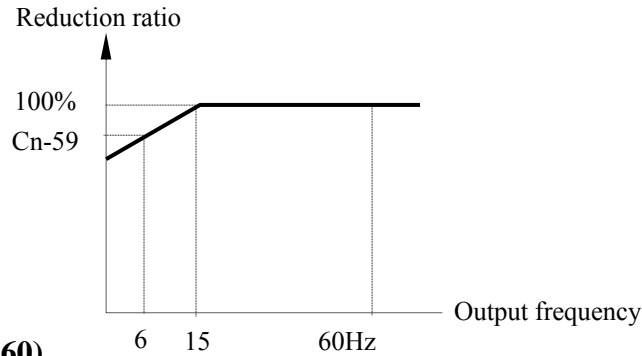
**(36) Motor code (Cn-60)**

- By setting this code, energy-saving coefficient is set to Cn-58 when a TECO motor is used. This motor code is the same as that used for motor constant setting (Sn-01) By setting the capacity and initializing by Sn-01, the same code is written to Cn-60. Therefore, when the inverter and motor has the same capacity, setting is not needed. When exclusive use motor or other manufacturer's motor is used and its motor constant is not known or when the inverter and motor has the different capacity, try to set the mother code corresponding to the motor voltage and capacity to Cn-60. The motor codes are shown in the table below.

**( 220V class )**

Cn-60	Motor Capacity	Cn-58 Initial value
04	5	122.90
05	7.5	94.75
06	10	72.69
07	15	70.44
08	20	63.13
9	25	57.87
0A	30	51.79
0B	40	46.27
0C	50	38.16
0D	60	35.78
0E	75	31.35
0F	100	23.10
10	125	14.85

**( 440V class )**

Cn-60	Motor Capacity	Cn-58 Initial value
24	5	245.80
25	7.5	189.50
26	10	145.38
27	15	140.88
28	20	126.26
29	25	115.74
2A	30	103.58
2B	40	92.54
2C	50	76.32
2D	60	71.56
2E	75	67.20
2F	100	46.20
30	125	41.22
31	150	36.23
32	175	33.88
33	215	30.13
34	250	29.20
35	300	27.13
36	350	24.45
37	400	21.76
38	500	16.38



**(37) Auto Restart Time Interval (Cn-62)**

- Set the auto reset / restart operation time interval when the number of auto reset / restart operation is more than 2.
- The setting range of Cn-62 is 0~20 sec, the auto restart time interval is minimum baseblock time (Cn-40) when the setting value of Cn-62 is 0.
- The auto restart time interval is the setting value of Cn-40 when the setting value of Cn-62 < Cn-40.
- The auto restart time interval is the setting value of Cn-62 when the setting value of Cn-62 > Cn-40.

**(38) Motor Overheat Protection Time (Cn-63)**

- Time delay for motor overheat protection when the detected temperature of PTC thermistor motor temperature sensor reached the trip level.
- Generally, it is not needed to change the set value of Cn-63, The factory setting is 150%, 1 minutes motor overheat capability.
- Refer to motor overheat protection setting of Sn-19.

## 2.4 System Parameters Sn-

Function	Parameter No.	Name	LCD Display (English)	Description	Factory Setting	Ref. Page
Capacity Setting	Sn-01	Inverter Capacity Selection	Sn-01=29 440V 25HP	Inverter Capacity Selection	*1	2-30 2-31
V/f Curve	Sn-02	V/f Curve Selection	Sn-02=2 V/f Curve	V/f pattern Selection	2	2-32
Operator Status	Sn-03	Operation Status	Sn-03=0000 Operate Setting	0000 : Setting and reading of An- , Bn- , Cn- , Sn- enabled 0101 : Setting and reading of An- , Reading of Bn- , Cn- , Sn- enabled 1110 : Contents Initialigation (2-wire)*2 1111 : Contents Initialigation (3-wire)*2 1000 : Initialize Un-11 contents 1001 : Initialize Un-12 contents	0000	2-33
Operation Mode Select	Sn-04	Operation Mode Select 1 (RUN . STOP Selection)	Sn-04=0011 Stopping Method	--0 : Frequency Command = Control circuit terminals VIN or AIN --1 : Frequency Command = Frequency Command 1 (An-01) --0- : RUN . STOP Command = Control circuit terminals --1- : RUN . STOP Command = Digital Operator 00-- : Stopping method = Ramp to stop 01-- : Stopping method =Coasting to stop 10-- : Stopping method =Full-range DC injection braking stop 11-- : Stopping method = Coasting stop (timer function provided)	0011	2-34 2-35 2-36
	Sn-05	Operation Mode Selection 2 (I/O terminal function selection)	Sn-05=0000 I/O Term. Fct.	--0 : Stop key effective during operation from control terminal --1 : Stop key effective during operation from control terminal --0- : Reverse run enabled --1- : Reverse run disabled -0-- : Control input terminals 1 ~ 8 are scanned twice. -1-- : Control input terminals 1 ~ 8 are scanned once. 0--- : Digital operator  key = JOG key function 1--- : Digital operator  key = L/R (Local/Remote) key function	0000	2-37
	Sn-06	Operation Mode Selection 3 (S-curve and frequency reference characteristics)	Sn-06=0000 S Curve & Cmd. Char.	--00 : S curve=0.2sec --01 : S curve=0.0sec (NO S curve) --10 : S curve=0.5sec --11 : S curve=1.0sec -0-- : Reference command has forward characteristics (0-10V or 4-20mA/0~100%) -1-- : Reference command has reverse characteristics (0-10V or 4-20mA/100~0%) 0--- : Stop by reference input when frequency reference is missing 1--- : Operation to continue with 80% of frequency reference when frequency reference is missing	0000	2-38 2-39 2-40

Function	Parameter No.	Name	LCD Display (English)	Description	Factory Setting	Ref. Page
Operation Mode Select	Sn-07	Operation Mode Selection 4 (overtorque detection)	Sn-07=0000 Over Tq. Detect	--0 : Overtorque detection not enabled --1 : Overtorque detection enabled -0- : Enabled only if at agreed frequency -1- : Enable during operation (except during DC injection) -0-- : Operation continued after overtorque is detected -1-- : Coasts to stop if overtorque is detected	0000	2-40 2-41
	Sn-08	Operation Mode Selection 5 (RS-485 communication status selection)	Sn-08=0111 RS485Comm. Function	--0 : Frequency reference input by RS-485 communication option card (PA-M or PA-P) --1 : Frequency reference input by digital operator or control circuit input terminals --0 : RUN/STOP command input by RS-485 Communication option card (PA-M or PA-P) --1 : RUN/STOP command input by digital operator or control circuit input terminals	0011	2-41 2-42
				00-- : RS-485 communication fault, deceleration to stop (Bn-02) 01-- : RS-485 communication fault, coast to stop 10-- : RS-485 communication fault, deceleration to stop (Bn-04) 11-- : RS-485 communication fault, continue to run		
Sn-09	Operation Mode Selection 6 (Energy saving function selection)	Sn-09=0000 Eng. Saving Function	-0-- : Energy-saving function ineffective -1-- : Energy-saving function ineffective	0000	2-42	
Protective Characteristic Select	Sn-10	Protective Characteristic Selection 1 (Stall prevention)	Sn-10=0000 Stall Select	--0 : Stall prevention during acceleration enabled --1 : Stall prevention during acceleration not enabled -0- : Stall prevention during acceleration enabled -1- : Stall prevention during acceleration not enabled -0-- : Stall prevention during running enabled -1-- : Stall prevention during running not enabled 0--- : Decel time during stall prevention=Bn=02 set value 1--- : Decel time during stall prevention=Bn=04 set value	0000	2-42 2-43
	Sn-11	Protective Characteristic Selection 2 (Retry and momentary power failure protection)	Sn-11=0000 Retry & Ride_Thru	-0- : Fault contact is not energized during Retry operation -1- : Fault contact is energized during Retry operation -0-- : Operation stopped by momentary power loss detection (UV1) -1-- : Operation continues after momentary power loss	0000	2-43 2-44

Function	Parameter No.	Name	LCD Display (English)	Description	Factory Setting	Ref. Page	
Protective Characteristic Select	Sn-12	Protective Characteristic Selection 3 (External Fault signal function)	Sn-12=0100 External Fault	--0 : External fault input (terminal 3): NO-contact input --1 : External fault input: NC-contact input --0 : External fault signal: always detected -1- : External fault signal: detected during running only 00- : External fault detected: Ramp to a stop (major fault) by Bn-02 set value 01- : External fault detected: Coasting to stop (major fault) 10- : External fault detected: Ramp to a stop (major fault) by Bn-04 set value 11- : External fault detected: operation to continue (major fault)	0100	2-44	
	Sn-13	Protective Characteristic Selection 4 (phase loss protection and cooling fan ON/OFF control)	Sn-13=0000 PhaseLoss& Fan Cont.	--0 : Input phase loss protection function ineffective --1 : Input phase loss protection function effective -0- : Output phase loss protection function ineffective -1- : Output phase loss protection function effective -0- : Cooling fan run while inverter power ON -1- : Cooling fan run while heat sink temperature higher than 50	0000	2-44 2-45	
	Sn-14	Protective Characteristic Selection 5 (Electronic thermal overload protection)	Sn-14=0000 Over Load Select	--0 : Motor overload (OL1) protection effective --1 : Motor overload (OL1) protection ineffective -0- : Motor overload protection: standard motor -1- : Motor overload protection: Inverter duty motor -0- : Motor overload protection time constants are standard time (8 minutes) -1- : Motor overload protection time constants are short-time (5 minutes)	0000	2-45	
Multi-Function Select	Sn-15	Terminal 5 Function	Sn-15=03 Term.5 Function	00~66	Terminal 5 (factory preset for multi-step speed reference 1)	03	2-46 ~ 2-55
	Sn-16	Terminal 6 Function	Sn-16=04 Term.6 Function	00~66	Terminal 6 (factory preset for multi-step speed reference 2)	04	
	Sn-17	Terminal 7 Function	Sn-17=06 Term.7 Function	00~66	Terminal 7 (factory preset for jog frequency reference)	06	
	Sn-18	Terminal 8 Function	Sn-18=08 Term.8 Function	00~66	Terminal 8 (factory preset for external baseblock by NO contact input)	08	
	Sn-19	Terminal AUX Function	Sn-19=00 Multi-Fo $\sqrt{\text{Input}}$	00~0C	Terminal AUX (factory preset for auxiliary frequency command)	00	2-56 2-57
	Sn-20	Terminal R2A-R2C Function	Sn-20=00 Term. R2A Function	00~0F	Terminal R2A-R2C (factory preset for running)	00	2-58 ~ 2-61
	Sn-21	Terminal D01 Function	Sn-21=01 Term. D01 Function	00~0F	Terminal D01 (factory preset for zero speed)	01	
	Sn-22	Terminal R1A Function	Sn-22=02 Term. R1A Function	00~0F	Terminal R1A (factory preset for Agreed frequency)	02	

Function	Parameter No.	Name	LCD Display (English)	Description	Factory Setting	Ref. Page
RS-485 communication Function	Sn-23	Inverter station address	Sn-23=01 Inverter Address	Inverter address can be set as 1~31	01	2-62
	Sn-24	RS-485 communication protocol setting	Sn-24=0011 RS-485 protocol	--00 : No parity --01 : Even parity --10 : Odd parity --11 : not used } parity setting  00-- : 2400 bps (bit/sec) 01-- : 4800 bps 10-- : 9600 bps 11-- : 19200 bps } baud rate setting	0011	
Language	Sn-25	LCD Language displayed selection	Sn-25=0 Language select	0 : English 1 : Chinese	1	2-63
Multi-Function Analog Output Selection	Sn-26	Multi-Function Analog Output A01 Function Selection	Sn-26=00 Term. A01 Function	0 : Frequency command (10V/max frequency command, Cn-02) 1 : Output Frequency (10V/max Output frequency) 2 : Output Current (10V/inverter rated current) 3 : Output Voltage (10V/input voltage, Cn-01) 4 : DC Voltage (10V/400VDC or 800VDC) 5 : Output Power (10V/max. applicable motor capacity)	0	2-63
	Sn-27	Multi-Function Analog Output A02 Function Selection	Sn-27=01 Term. A02 Function	0 : Frequency command (10V/max frequency command, Cn-02) 1 : Output Frequency (10V/max Output frequency) 2 : Output Current (10V/inverter rated current) 3 : Output Voltage (10V/input voltage, Cn-01) 4 : DC Voltage (10V/400VDC or 800VDC) 5 : Output Power (10V/max. applicable motor capacity)	1	2-63
-	Sn-28	Not used	Sn-28=0 Reserved	-	-	-
-	Sn-29	Not used	Sn-29=0 Reserved	-	-	-
PA-PID Card Function Selection	Sn-30	Pump Operation Mode Selection	Sn-30=0 Run-Mode Select	0 : PA-PID Card ineffective 1 : Fixed inverter driving mode, stop all the pumps by first-run-last-stop sequence. 2 : Fixed inverter driving mode, stop the pump driven by the inverter only. 3 : Fixed inverter driving mode, stop all the pumps by first-run-first-stop sequence. 4 : Cycled inverter driving mode, stop all the pumps by first-run-first-stop sequence. 5 : Cycled inverter driving mode, stop the pump driven by the inverter only.	0	2-64

Function	Parameter No.	Name	LCD Display (English)	Description	Factory Setting	Ref. Page
PA-PID Card Relay Control	Sn-31	PA-PID Card Relay 2 Control	Sn-31=0 Invalid	0 : Relay 2 Invalid 1 : Relay 2 Valid	0	2-65
	Sn-32	PA-PID Card Relay 3 Control	Sn-32=0 Invalid	0 : Relay 3 Invalid 1 : Relay 3 Valid	0	
	Sn-33	PA-PID Card Relay 4 Control	Sn-33=0 Invalid	0 : Relay 4 Invalid 1 : Relay 4 Valid	0	
	Sn-34	PA-PID Card Relay 5 Control	Sn-34=0 Invalid	0 : Relay 5 Invalid 1 : Relay 5 Valid	0	
	Sn-35	PA-PID Card Relay 6 Control	Sn-35=0 Invalid	0 : Relay 6 Invalid 1 : Relay 6 Valid	0	
	Sn-36	PA-PID Card Relay 7 Control	Sn-36=0 Invalid	0 : Relay 7 Invalid 1 : Relay 7 Valid	0	
	Sn-37	PA-PID Card Relay 8 Control	Sn-37=0 Invalid	0 : Relay 8 Invalid 1 : Relay 8 Valid	0	
Parameter Copy	Sn-38	Parameter copy	Sn-38=0 Not Loaded	0 : Not loaded (not copied) 1 : Upload (from digital operator to inverter) 2 : Download (from inverter to digital operator) 3 : Inspect the EEPROM of digital operator	0	2-65

\*1 Differs according to inverter capacity.

\*2 Initialization (Sn-03 = 1110, 1111)

After depressing the **ENTER** key, input the initial value of An-□□, Bn-□□, Sn-□□, Cn-□□, (except Sn-01, Sn-02) into NV-RAM, When the value is written in without an error, “Entry Accepted” is displayed. When the value is written in with an error, “\*\*Error” is displayed. The values of Sn-15 to -18 differ as follows between initializations with Sn-03 = 1110 and with Sn-03 = 1111.

Multi-function Terminal	1110 (2 Wire Sequence)	1111 (3 Wire Sequence)
Terminal 5 (Sn-15)	3* (Multi-step speed command 1)	0 (FWD/REV run select)
Terminal 6 (Sn-16)	4* (Multi-step speed command 2)	3 (Multi-step speed reference 1)
Terminal 7 (Sn-17)	6* (Jog frequency reference)	4 (Multi-step speed reference 2)
Terminal 8 (Sn-18)	8* (External baseblock command)	6 (Jog frequency reference)

\*Values have been factory-set.

\*\* Contents depend on the parameter setting items.

- Sn-XX =

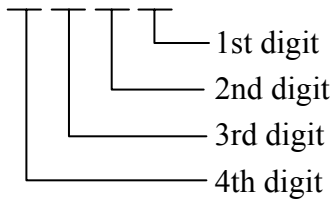

### (1) Inverter Capacity Selection (Sn-01)

- Inverter capacity has been preset at the factory. However, if a spare board is used, reset the inverter capacity referring to the table below. Control constant Cn-□□□□ factory setting values (initial values) differ according to Sn-01 setting.

### Inverter Capacity Selection

#### 220V Class

Name		Data of Sn-01													
		04	05	06	07	08	09	0A	0B	0C	0D	0E	0F	10	
BA JNTPBG BB □□□□ JK - - -		0005	7R50	0010	0015	0020	0025	0030	0040	0050	0060	0075	0100	0125	
Inverter rated capacity (KVA)		6.2	9.3	12.4	18.6	24.8	27.4	33	44	55	63	81	110	125	
Max. applicable motor capacity HP (kW)		5 (3.7)	7.5 (5)	10 (7.5)	15 (11)	20 (15)	25 (18.5)	30 (22)	40 (30)	50 (37)	60 (45)	75 (55)	100 (75)	125 (90)	
Inverter rated current (A)		16	24	32	48	64	72	88	117	144	167	212	288	327	
Factory Set	Cn-09	Motor rated current (A)	13.5	20.1	25.1	36.7	50.3	62	73	97.4	118	141	176	227	284
	Cn-23	Carrier frequency upper limit (kHz)	10.0	10.0	10.0	10.0	10.0	6.0	6.0	6.0	6.0	3.0	3.0	3.0	3.0
	Cn-24	Carrier frequency lower limit (kHz)	10.0	10.0	10.0	10.0	10.0	6.0	6.0	6.0	6.0	3.0	3.0	3.0	3.0
	Cn-25	Carrier frequency proportional gain	0	0	0	0	0	0	0	0	0	0	0	0	0
	On-17	Motor phase-to-phase resistance ( )	0.684	0.444	0.288	0.159	0.109	0.077	0.060	0.041	0.033	0.028	0.019	0.007	0.005
	On-18	Torque compensation iron loss (W)	208	252	285	370	471	425	582	536	641	737	790	1800	2100
	On-19	Torque compensation limit (V)	50	50	50	50	50	50	50	50	50	50	50	50	50
	Cn-37	Momentary power loss assurance time (s)	2.0	2.0	2.0	2.0	2.0	2.0	2.0	2.0	2.0	2.0	2.0	2.0	2.0
	Cn-40	Minimum baseblock time (s)	0.5	0.7	0.7	0.7	0.7	1.0	1.0	1.0	1.0	1.0	1.0	1.0	1.0
Cn-41	V/f during speed search (%)	100	100	100	100	100	100	100	80	80	80	80	80	80	

Inverter Capacity Selection

440V Class

Name		Data of Sn-01																					
		24	25	26	27	28	29	2A	2B	2C	2D	2E	2F	30	31	32	33	34	35	36	37	38	
BA JNTPBG BB <input type="checkbox"/> <input type="checkbox"/> <input type="checkbox"/> <input type="checkbox"/> <input type="checkbox"/> AZ ---		0005	7R50	0010	0015	0020	0025	0030	0040	0050	0060	0075	0100	0125	0150	0175	0215	0250	0300	0350	0400	0500	
Inverter rated capacity (KVA)		6.2	9.3	12.4	18.6	24.8	29	34	45	57	66	85	115	144	176	203	232	259	290	393	446	558	
Max. applicable motor capacity HP(kW)		5 (3.7)	7.5 (5)	10 (7.5)	15 (11)	20 (15)	25 (18.5)	30 (22)	40 (30)	50 (37)	60 (45)	75 (55)	100 (75)	125 (90)	150 (110)	175 (132)	215 (160)	250 (185)	300 (220)	350 (260)	400 (300)	500 (375)	
Inverter rated current (A)		8	12	16	24	32	38	44	59	75	86	111	151	189	231	267	304	340	380	516	585	732	
Factory Set	Cn-09	Motor rated current (A)	6.8	10.1	12.6	18.6	24.8	31	36	49	59	71	88	114	143	175	205	235	305	348	410	465	582
	Cn-23	Carrier frequency upper limit (kHz)	10.0	10.0	10.0	10.0	10.0	6.0	6.0	6.0	6.0	6.0	6.0	3.0	3.0	3.0	3.0	3.0	3.0	2.0	2.0	2.0	2.0
	Cn-24	Carrier frequency lower limit (kHz)	10.0	10.0	10.0	10.0	10.0	6.0	6.0	6.0	6.0	6.0	6.0	3.0	3.0	3.0	3.0	3.0	3.0	2.0	2.0	2.0	2.0
	Cn-25	Carrier frequency proportional gain	0	0	0	0	0	0	0	0	0	0	0	0	0	0	0	0	0	0	0	0	0
	On-17	Motor phase-to-phase resistance ( )	2.735	1.776	1.151	0.634	0.436	0.308	0.239	0.164	0.133	0.110	0.074	0.027	0.036	0.023	0.020	0.022	0.014	0.012	0.01	0.009	0.007
	On-18	Torque compensation iron loss (W)	208	252	285	370	471	425	582	536	641	737	790	1800	2900	2500	2600	2500	2600	2800	2400	3200	3600
	On-19	Torque compensation limit (V)	100	100	100	100	100	100	100	100	100	100	100	100	100	100	100	100	100	100	100	100	100
	Cn-37	Momentary power loss assurance time (s)	2.0	2.0	2.0	2.0	2.0	2.0	2.0	2.0	2.0	2.0	2.0	2.0	2.0	2.0	2.0	2.0	2.0	2.0	2.0	2.0	2.0
	Cn-40	Minimum baseblock time (s)	0.5	0.7	0.7	0.7	0.7	1.0	1.0	1.0	1.0	1.0	1.0	1.0	2.0	2.0	2.0	2.0	2.0	2.0	2.0	2.0	2.0
Cn-41	V/f during speed search (%)	100	100	100	100	100	100	100	100	100	100	80	80	80	80	80	80	80	80	80	80	80	

**(2) V/F Curve Selection (Sn-02)**

- V/F curve is selected by the setting of Sn-02. When V/F curve is selected, never to fail to set input voltage of the inverter to Cn-01.

- Sn-02=0~3 : pre-set V/F curve pattern.

Sn-02=0~4 : V/F pattern can be set by the user through setting of Cn-02~Cn-08.

Table 12 V/F curve of 220V class

Sn-02setting	Specifications	V / F pattern
0	50Hz, Saturation Variable Torque (quadratic monotonically decreasing curve)	
1	50Hz, Saturation Variable Torque (cubic monotonically decreasing curve)	
2	60Hz, Saturation Variable Torque (quadratic monotonically decreasing curve)	
3	60Hz, Saturation Variable Torque (cubic monotonically decreasing curve)	

\*1. Consider the following items as the conditions for selecting a V/F pattern.

They must be suitable for

- 1 The voltage and frequency characteristic of motor.
- 2 The maximum speed of motor.

\*2. For 440V class, 2 times voltage value shown in table above.

**(3) Operation status (Sn-03)**

- Passwords (Sn-03=0000 or 0101)

The ability to set or read the different groups of constants is determined by Sn-03 as shown below.

Sn-03	DRIVE mode		PRGM mode	
	To be set	To be monitored	To be set	To be monitored
0000 <sup>*1</sup>	An, Bn	Sn, Cn	An, Bn, Sn, Cn	-
0101 <sup>*2</sup>	An	Bn, Sn, Cn	An	Bn, Sn, Cn

\*1 : Factory setting

\*2 : When in DRIVE mode, the parameter group Sn-, Cn- can only be monitored if the



key and the key are to be pressed at the same time.

\*3 : After a few trial operation and adjustment, the setting value Sn-03 is set to be “1111” so as not be modified again.

- Constants Initialization (Sn-03=1110 or 1111)

Except the parameter of Sn-01~02, the parameter groups of An-, Bn-, Cn-, Sn- and On- can be initialized as factory setting. At the same time, the terminal 5~8 can be set as 2-wire or 3-wire operation mode under different setting of Sn-03, please see 2-/3-wire operation mode on page 2-46.

- Special mode (Sn-03=1010)

The order parameters On- can be set and read when setting Sn-03=1010, after changing or monitoring any of the On- parameters, please set Sn-03=0000 or 0101.

- Initialize the contents of monitoring parameter Un-11 and Un-12 (Sn-03=1000 and 1001)

The motor elapsed run hours (Un-11) and motor elapsed energy KWHR (Un-12) can be reset by Sn-03=1000 and 1001 individually.

- The LCD display (English) as below.

Sn-03 setting	LCD Display
0000	Sn-03=0000 Allow Setting
0101	Sn-03=0101 Inhibit Setting
1110	Sn-03=1110 2-Wire Initialize
1111	Sn-03=1111 3-Wire Initialize
1000	Sn-03=1000 Reset Un-11
1001	Sn-03=1001 Reset Un-12

**(4) Operation Mode Select 1 (Sn-04)**● **1st digit** (frequency reference select)

1st digit = 0 : Reference input from control circuit terminal 13 or 14 is the master speed frequency reference.

1st digit = 1 : Frequency reference 1 (An-01) is the master speed frequency reference.

Note : For combination of multi-step speed operation, refer to page 2-48 and 2-49.

● **2nd digit** (run command select)

2nd digit = 0 : Run command from control circuit terminal is accepted.

2nd digit = 1 : Run command from the digital operator is accepted.

Valid run command and frequency references differ as shown in the table below, depending on the combination of the 1st and 2nd digits.

CONSTANT REF	Sn-04	2nd digit	1st digit	2nd digit	1st digit	2nd digit	1st digit	2nd digit	1st digit	
		0	0	0	1	1	0	1	1	
Control Terminal	Master Speed Frequency Ref.	Control circuit terminal VIN, AIN		An-01		Control circuit terminal VIN, AIN		An-01		
	FWD Run Command (Terminal 1)					×		×		
	REV Run Command (Terminal 2)					×		×		
	External Fault (Terminal 3)									
	Fault Reset (Terminal 4)		* 1		* 1		* 1		* 1	
	Command of Terminal 5						* 2		* 2	
	Command of Terminal 6									
	Command of Terminal 7									
	Command of Terminal 8									
	Aux. Input									
	Fault Contact Output (R1A-R1B-R1C)									
	Multi-function Contact Output (R2A, R3A)									
	Multi-function PHC Output (D01)									
Operator	RUN Key		×		×					
	JOG Key		×		×					
	STOP Key		* 3		* 3					
	FWD/REV Key		×		×					
	> / RESET Key		* 1		* 1		* 1		* 1	
	DRIVE / PRGM Key		Valid only when the inverter stop		Valid only when the inverter stop		Valid only when the inverter stop		Valid only when the inverter stop	
	LED of REF		Lit		OFF		Lit		OFF	
	LED of SEQ		Lit		Lit		OFF		OFF	
Monitor display										

- \* 1 Valid only when the inverter stops. (FWD run command, REV run command, and DC injection braking command are "open".)
- \* 2 FWD/REV run command is not accepted.
- \* 3 When the STOP key is depressed, processing differs as follows, depending on the setting of the 1st digit of Sn-05.
  - 1st digit=0: During running by signals from control circuit terminals, the STOP key from the operator is accepted.  
If the STOP key is depressed, the inverter stops according to the setting of 3rd and 4th digits of Sn-04, while the STOP LED indicator blinks. This stop command is held within the inverter until both the FWD run command and REV run command of control circuit terminals become "open", or another frequency reference is selected in the multi-step speed command or jog frequency reference section.
  - 1st digit=1: During running by signals from control circuit terminals, the STOP key from the operator is not accepted.

● **3rd digit, 4th digit** (stop method select)

Stop method differs by the setting of 3rd and 4th digits as shown below.

1 Sn-04=00 XX RAMP stop

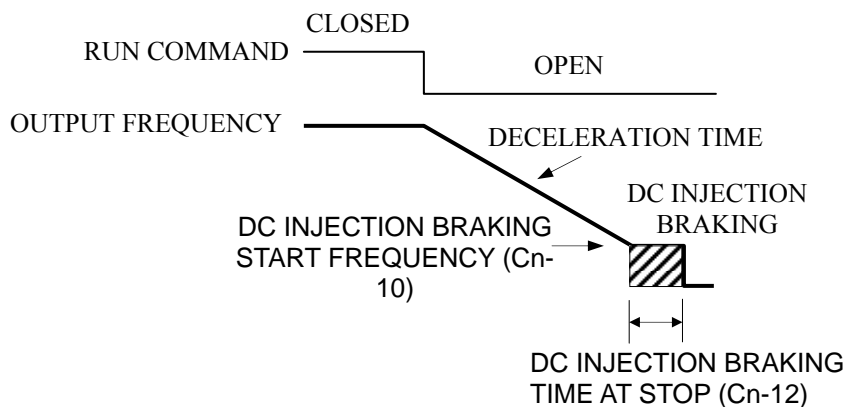

2 Sn-04=01 XX Coasting to a stop

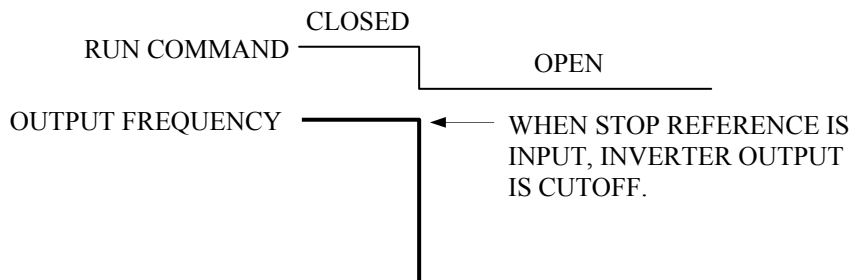

3 Sn-04=10 XX Full-range DC injection braking stop

- DC injection braking time differs by the output frequency when stop command is input as shown below.

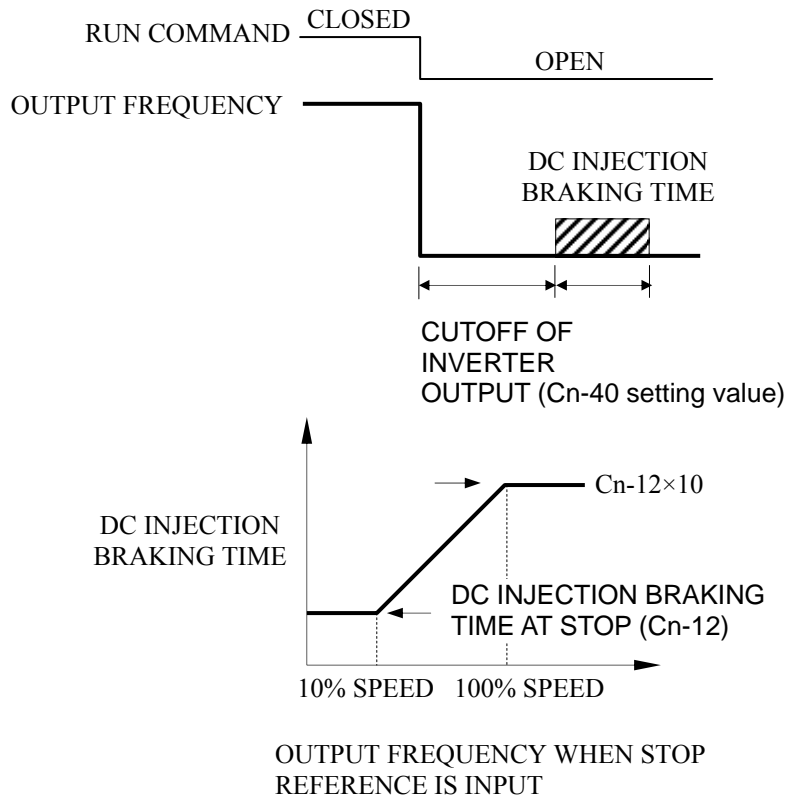

4 Sn-04=11 XX Coasting to a Stop (timer function provided)

- Once stop command is input, run command is disregarded during  $T_1$  time.

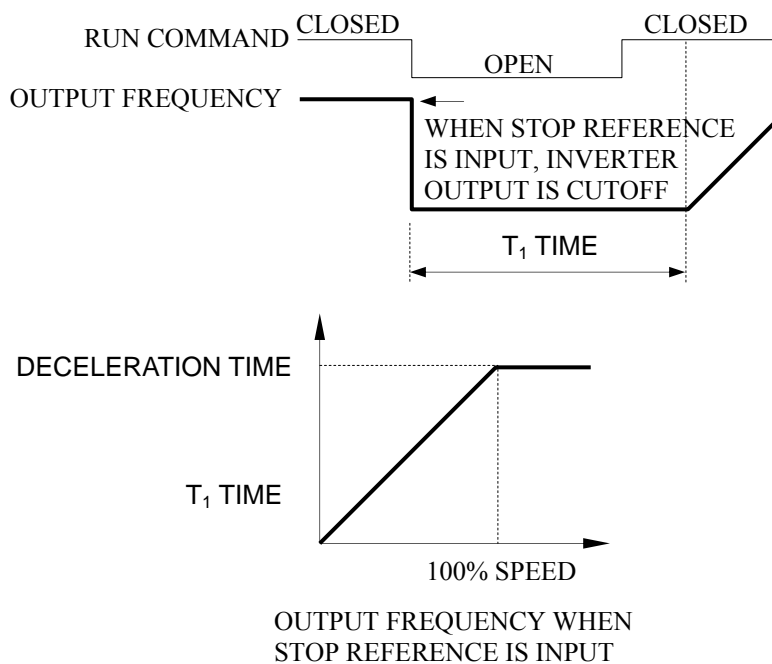

## (5) Operation Mode Select 2 (Sn-05)

### ● 1st digit

Select processing to be performed when the STOP key of the digital operator is depressed during running by control circuit terminals.

1st digit = 0 : During running by signals from control circuit terminals, the STOP key from the operator is accepted. If the STOP key is depressed, the inverter stops according to the setting of the 3rd and 4th digits of Sn-04 while the STOP LED indicator blinks. This stop command is held within the inverter until both the FWD run command and REV run command of control circuit terminals become "open", or other frequency reference is selected in the multi-step speed command or jog frequency reference section.

1st digit = 1 : During running by signals from control circuit terminals, the STOP key from the operator is not accepted.

### ● 2nd digit (REV run prohibited)

2nd digit = 0 : REV run command from control circuit terminals or the digital operator is accepted.

2nd digit = 1 : REV run command from control circuit terminals or the digital operator is not accepted.

### ● 3rd digit (selection of double scanning of sequence command)

3rd digit = 0 : Sequence command (control circuit terminals I to 8) is scanned twice.

3rd digit = 1 : Sequence command (control circuit terminals I to 8) is scanned once.

### ● 4th digit ( $\begin{matrix} \text{JOG} \\ \text{(L/R)} \end{matrix}$ key functions select )

4th digit=0 : The digital operator  $\begin{matrix} \text{JOG} \\ \text{(L/R)} \end{matrix}$  key is JOG key function.

(the JOG key function is enabled under Local mode )

4th digit=1 : The digital operator  $\begin{matrix} \text{JOG} \\ \text{(L/R)} \end{matrix}$  key is used as Local/Remote (L/R) switch key.

⇒ At the Local mode, the inverter operates by frequency reference and run command from digital operator.

⇒ At the Remote mode, if selected the multi-function contact input (terminal ⑤~⑧) as Local/Remote operation signal

(i.e. the set value of Sn-15~18 is 0 1)

① if terminal ⑤~⑧="open"(Remote mode), the inverter operates according to the setting of Sn-04 1 st , 2 nd digits and Sn-08 1 st , 2 nd digits (i.e. the  $\begin{matrix} \text{JOG} \\ \text{(L/R)} \end{matrix}$  key used as Remote key function.)

② if terminal ⑤~⑧="close"(Local mode), the inverter operates by frequency reference and run command from digital operator.

(i.e. the Remote key function invalid).

\*.The Local/Remote (L/R) key function is enabled only stopping.

**(6) Operation Mode Select 3 (Sn-06)**

- **1st digit, 2nd digit** (s-curve selection of soft starter)

The S-curve characteristics of the soft starter depend on the setting of the 1st and 2nd digits as follows:

2nd digit	1st digit	Contents
0	0	The S-curve characteristics is 0.2 second.
0	1	No S-curve characteristics
1	0	The S-curve characteristics is 0.5 second.
1	1	The S-curve characteristics is 1 second.

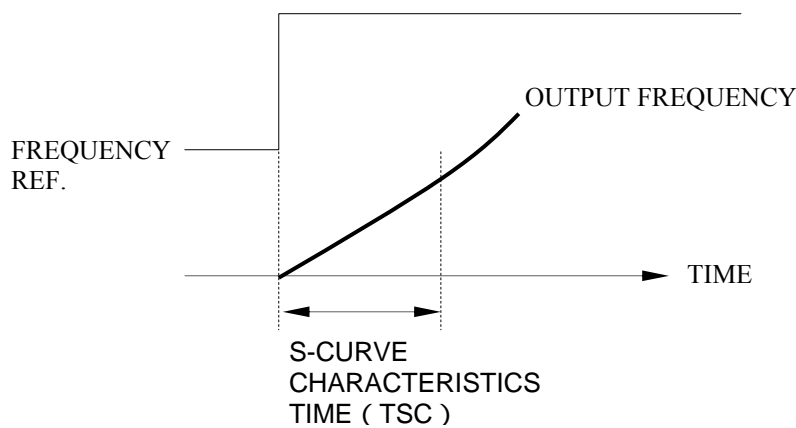

Note: S-curve characteristics time refers to the time from acceleration rate 0 to the time when a normal acceleration rate determined by a specified acceleration time is obtained.

**a Time chart at FWD/REV run change with S-curve characteristics**

- The figure below shows the time chart at FWD/REV run change during deceleration and stop.

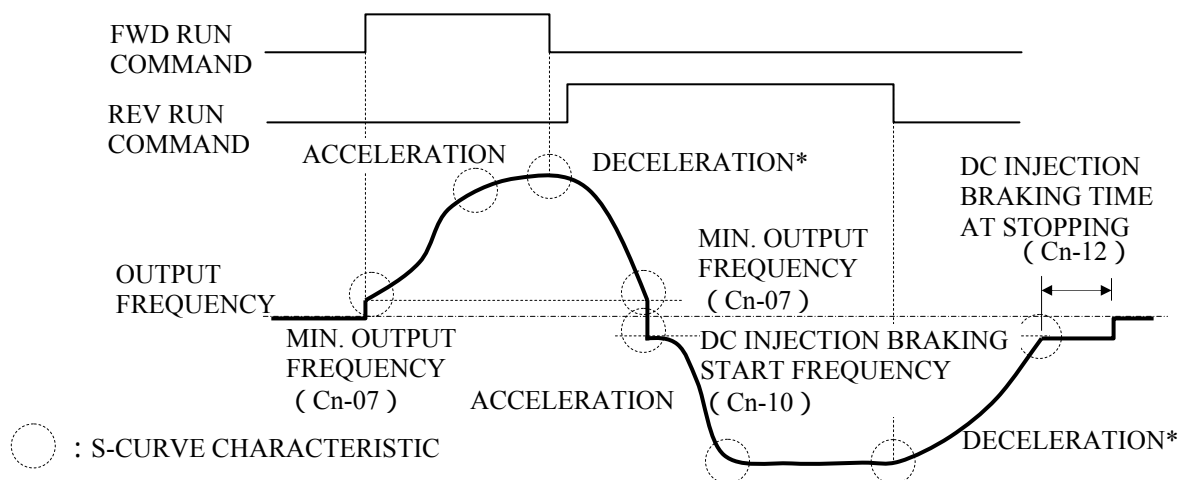

\* When 1st and 2nd digits are 00,  
no S-curve characteristics at completion of deceleration.

b **The chart at FWD/REV run change without S-curve characteristics**

- The figure below shows the time chart at FWD/REV run change during deceleration and stop.

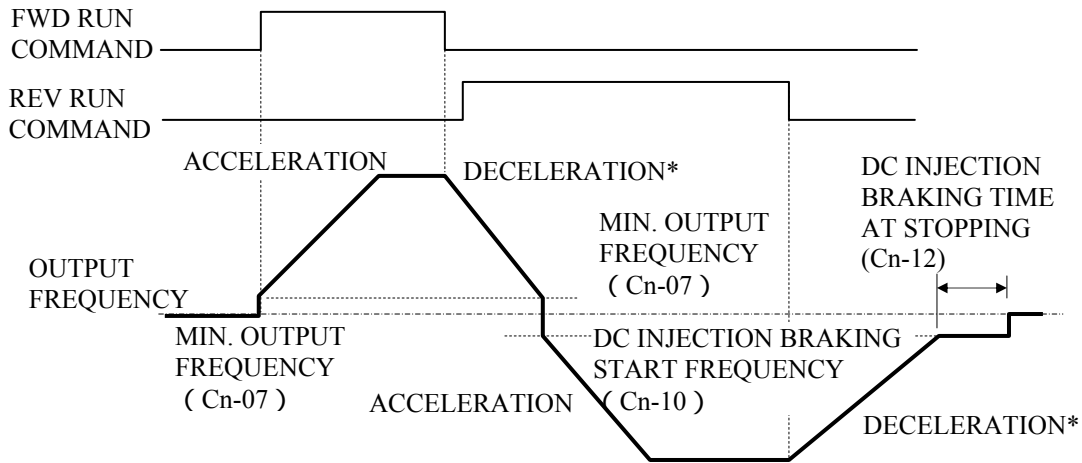

- **3rd digit** (reverse characteristics select)

The input characteristics of the master speed frequency reference depend on the set value as follows. For the reverse characteristics, only + input is valid.

3rd digit = 0 : Normal characteristics (0-10V or 4-20mA/0-100%)

3rd digit = 1 : Reverse characteristics (10-0V or 20-4mA/0-100%)

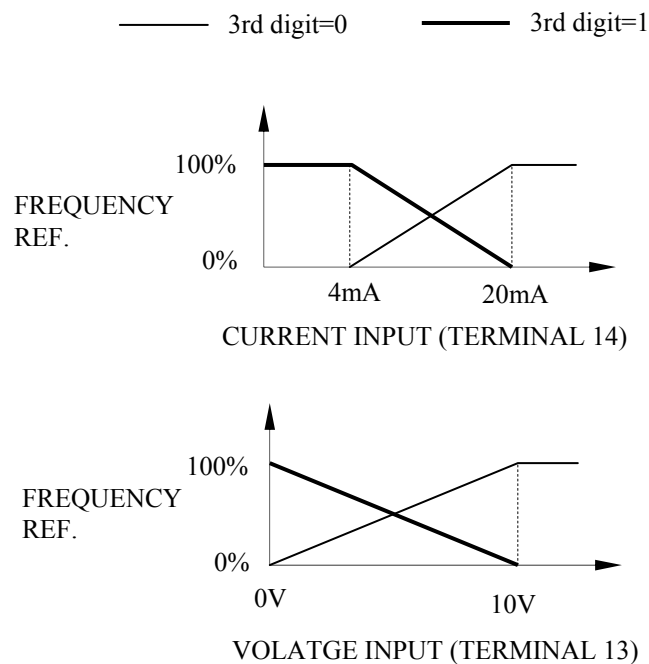

- **4th digit** (operation select when frequency reference is missing)
  - 4th digit = 0 : Normal operation (varies with change of reference)
  - 4th digit = 1 : Operation continues with 80% frequency.

When 4th digit = 1 is set, the current master speed frequency reference is compared at all times with the one occurred 0.4 second before. When the current master speed frequency reference goes below 10% of the one that occurred 0.4 second before, operation continues with 80% (80% frequency) of the master speed frequency reference of the prior one. Consequently, the master speed frequency reference of the previous one (0.4 second before) is used as the current frequency reference.

In the following cases, this operation is released and the inverter returns to normal operation:

- Master speed frequency reference exceeding 80% frequency is input.
- Stop reference is input.
- Reference is missing during operation at less than 5% of frequency.

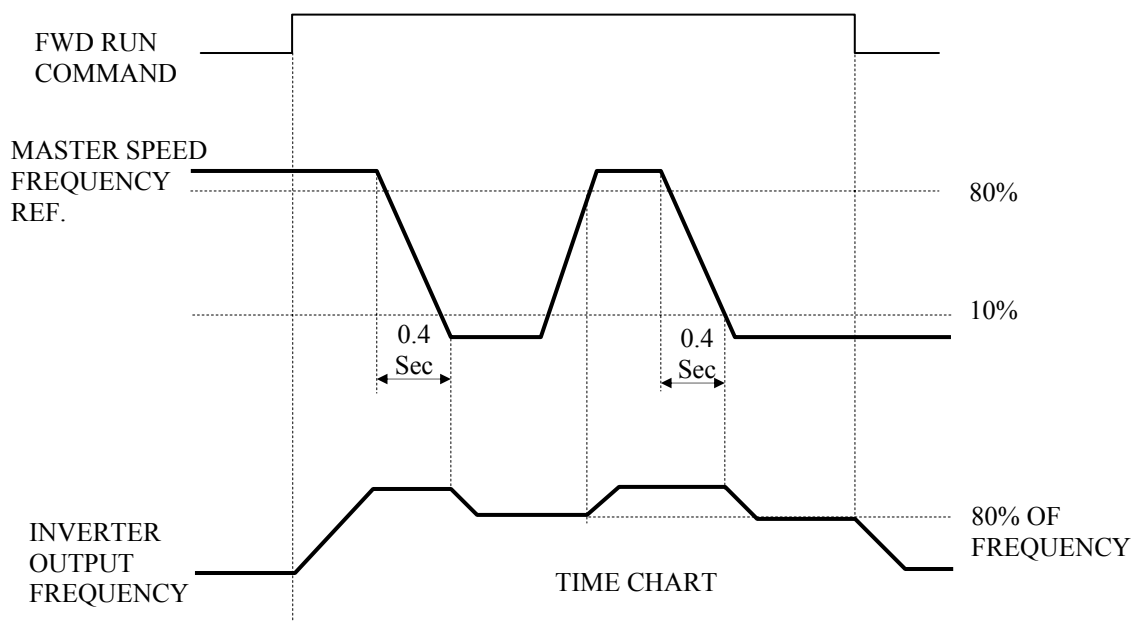

### (7) Operation Mode Select 4 (Sn-07)

Define the operation at overtorque detection. Overtorque is detected by the following formula:

Inverter output current B overtorque detection level (Cn-26, Initial value: 160 %)

(Detection time Cn-27, Initial value: 0.1 second, Hysteresis fixed at 10%)

- **1st digit**
  - 1st digit = 0 : Overtorque is not detected.
  - 1st digit = 1 : Overtorque is detected.

- **2nd digit**

2nd digit = 0 : Overtorque is detected only during agreed frequency.

2nd digit = 1 : Overtorque is detected during stop or during running except for DB.

- **3rd digit**

3rd digit = 0 : When overtorque is detected, "Over Torque OL3" blinks in the digital operator and the operation continues.

3rd digit = 1 : When overtorque is detected, "Over Torque OL3" displayed on the digital operator and the inverter output is shut OFF. Fault contact signal is output. (Treated as a fault)

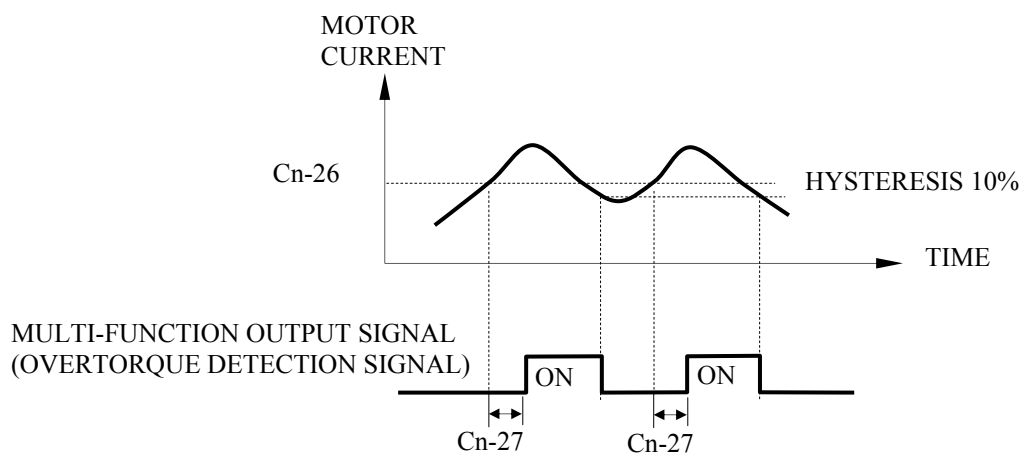

Setting either Sn-20 to 22 to "OB" enables signal to be output at overtorque detection.

## (8) Operation Mode Select 5 (Sn-08)

- **1st digit** (frequency reference input by RS-485 option card or inverter unit select)

Specify whether RS-485 option card (PA-M or PA-P) or inverter frequency reference is used for operation.

1st digit = 0 : RS-485 Option card frequency reference is accepted.

1st digit = 1 : Frequency reference from inverter control circuit terminals or the digital operator is accepted.

- **2nd digit** (RUN/STOP command input by RS-485 option card or inverter unit select)

2nd digit = 0 : RS-485 option card RUN/STOP command is accepted.

2nd digit = 1 : RUN/STOP command from inverter control circuit terminals or the digital operator is accepted.

- **3rd, 4th digit** (RS-485 stopping method after communication error)

3rd digit	4th digit	Contents
0	0	Ramp to a stop by Bn-02, When RS-485 has communication error.
0	1	Coasting to a stop, When RS-485 has communication error.
1	0	Ramp to a stop by Bn-04, When RS-485 has communication error.
1	1	Operation to continue (will stop if the key stop is pressed)

**(9) Operation Mode Select 6 (Sn-09)**

- **1st, 2nd digit** (Not used)

- **3rd digit** (energy-saving function selection)

3rd digit = 0 : Energy-saving function ineffective and operation is performed with normal V/f control.

3rd digit = 1 : Energy-saving function effective.

- **4th digit** (Not used)

**(10) Protective Characteristics Select 1 (Sn-10)**

- **1st digit** (selection of stall prevention during acceleration)

1st digit = 0 : Stall prevention during acceleration is enabled.

1st digit = 1 : Stall prevention during acceleration is not enabled.

The function of stall prevention during acceleration automatically extends acceleration according to load status (inverter output current), thus preventing the motor from stalling during acceleration. The stall prevention level during acceleration in a constant output area is reduced as follows:

$$\text{Acceleration stall prevention level of constant output field} = \frac{\text{acceleration stall prevention level (Cn-28)} \times \text{maximum voltage frequency (Cn-04)}}{\text{output frequency}}$$

When the 1st digit of Sn-10 is 1, the output frequency increases at the rate determined by acceleration time:

- **2nd digit** (selection of stall prevention during deceleration)

2nd digit = 0 : Stall prevention during deceleration is enabled.

2nd digit = 1 : Stall prevention during deceleration is not enabled.

The function of stall prevention during deceleration automatically extends deceleration time according to the magnitude of the main circuit DC voltage, thus preventing overvoltage during deceleration.

When the 2nd digit of Sn-10 is 1, the output frequency decreases at the rate determined by deceleration time. For positioning application, specify "stall prevention during deceleration not provided" (2nd digit = 1) in order to obtain stopping accuracy. With large load inertia, use a braking resistor (For 440V: 5HP~30HP and 220V: 5HP~25HP) or braking unit with braking resistor to prevent overvoltage.

- **3rd digit** (stall prevention during running)

3rd digit = 0 : Stall prevention during running is enabled.

3rd digit = 1 : Stall prevention during running is not enabled.

Stall prevention operation during running starts decelerating when the output current reaches 100 ms or greater than the set value of Cn-30 during frequency coincidence (operation level of stall prevention during running). The inverter decelerates as long as the output current exceeds the set value of Cn-30 (operation level of stall prevention during running). When the output current goes below the set value, the inverter reaccelerates. The deceleration time selected in the 4th digit of Sn-10 is taken. Even during stall prevention while running, stall prevention during deceleration and stall prevention during acceleration are enabled.

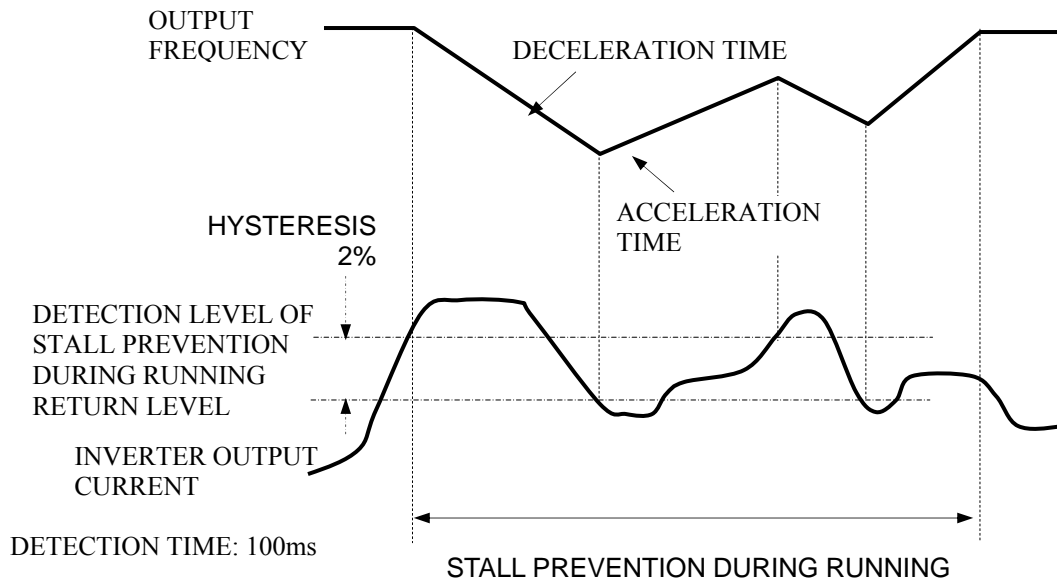

- **4th digit** (selection of deceleration time during stall prevention while running)

4th digit = 0 : The inverter decelerates for the deceleration time specified in bn-02.

4th digit = 1 : The inverter decelerates for the deceleration time specified in bn-04.

## (11) Protective Characteristics Select 2 (Sn-11)

- **1st digit** (Not used)

- **2nd digit** (fault contact signal during auto reset/restart operation)

2nd digit = 0 : A fault contact signal is not output during auto reset/restart operation.

2nd digit = 1 : A fault contact signal is output during auto reset/restart operation.

- **3rd digit** (operation continued at momentary power loss)

3rd digit = 0 : When momentary power loss is detected, under-voltage fault (UV1) occurs and the inverter output is shut off.

3rd digit = 1 : If momentary power loss time is within momentary power loss ride-thru time (Cn-37), the operation Continues after the momentary power loss. If the momentary power loss ride-thru time is exceeded, under-voltage fault (UV1) occurs and the inverter output is shut OFF.

Notes:

1. When the 3rd digit = 1, be sure not to shut OFF the external sequence signal (e.g. FWD, REV)
2. For lifters, do not use this function (the 3rd digit = 0)

- **4th digit** (Not used)

### (12) Protective Characteristics Select 3 (Sn-12)

When an external fault signal of terminal 3 is input, "Ext. Fault 3 EF3" is displayed and a fault contact signal is output immediately. The inverter stops according to the setting of the 3rd and 4th digits. The external fault signal is held within the inverter until a fault reset signal is input.

- **1st digit** (level selection of external fault signal)

1st digit = 0 : NO-contact input (when "closed", external fault operation is performed)

1st digit = 1 : NC-contact input (when "open", external fault operation is performed)

- **2nd digit** (acceptance of external fault signal)

2nd digit = 0 : External fault signals are always accepted.

2nd digit = 1 : External fault signals are accepted only during running. (Not accepted during baseblock)

- **3rd digit, 4th digit** (selection of processing at external fault detection)

3rd digit	4th digit	Contents
0	0	Ramp to a stop by Bn-02 (major fault).
0	1	Coasting to a stop (major fault).
1	0	Ramp to a stop by Bn-04 (major fault).
1	1	Operation to continue (minor fault).

### (13) Protective Characteristics Selection 4 (Sn-13)

- **1st digit** (Input Phase Loss Protection, IPL)

The input phase loss protection, function is disabled when input phase loss detection level Cn-61=100%. The effectiveness or ineffectiveness of input phase loss protection function can also be selected by the 1st digit of Sn-13.

1st digit = 0 : Input Phase Loss protection function ineffective.

1st digit = 1 : Input Phase Loss protection function effective.

- **2nd digit** (Output Phase Loss Protection, OPL)

The output phase loss protection function is disabled during the inverter is stop or DC injection braking or inverter output current 30% of inverter rated output current. The effectiveness or ineffectiveness of output phase loss protection function can also be selected by the 2nd digit of Sn-13.

2nd digit = 0 : Output Phase Loss protection function ineffective.

2nd digit = 1 : Output Phase Loss protection function effective

- **3rd digit** (Heat Sink Cooling Fan ON/OFF Control)

3rd digit = 0 : Inverter heat sink cooling fan runs while the inverter power ON.

3rd digit = 1 : Inverter heat sink cooling fan runs only while the heat sink temperature is higher than 50 .

(Only for 30~125HP in 220V class and 40~300HP in 440V class.)

#### (14) Protective Characteristics Selection 5 (Sn-14)

- **1st digit** (motor protection)

1st digit = 0 : Electronic thermal motor protection is enabled.

1st digit = 1 : Electronic thermal motor protection is not enabled.

- **2nd digit** (selection of electronic thermal characteristics)

2nd digit = 0 : Electronic thermal characteristics are in accordance with reduced torque motor (standard motor).

2nd digit = 1 : Electronic thermal characteristics are in accordance with constant torque motor (special motor).

- **3rd digit** (electronic thermal time constant)

3rd digit = 0 : Used for standard motor and special motor (standard-time ratings, 8 minutes)

3rd digit = 1 : Used for motors other than the above (short-time ratings, 5 minutes)

- The electronic thermal overlaid function monitors motor temperature, based on inverter output current and time, to protect the motor from overheating. When electronic thermal overload relay is enable, on "OL1" error occurs, shutting OFF the inverter output and preventing excessive overheating in the motor.

- When operating with one inverter connected to one motor, an external thermal relay is not needed. When operating several motors with one inverter, install a thermal relay on each motor, In this case, set constant Sn-14=XXX1.

- **4th digit** (Not used)

**(15) Multi-Function Contact Input Selection (Sn-15~Sn-18)**

- Select the set values shown below for Sn-15 to -18.

Terminal No	Sn- [ ][ ]
Terminal 5	15
Terminal 6	16
Terminal 7	17
Terminal 8	18

Set Value	Function	LCD display (English)	Description
00	FWD / REV RUN select	3-wire RUN	Open: FWD run, Closed: REV run, <span style="font-size: 2em; vertical-align: middle;">}</span> 3-wire sequence mode (00 set in Sn-15) terminal 1-run, 2-stop, 5 FWD / REV selection
01	Operation signal select Local / Remote	LOC / REMOT control	Open: Operated according to setting of Sn-04 1st, 2nd digits and Sn-08 1st, 2nd digits. Closed: Operated by frequency reference and run command from digital operator. (Local mode)
02	Option / inverter reference select	Opt. Card Switch	Open: Operated by operation or frequency reference from option. Closed: Operated by operation or frequency reference from inverter.
03	Multi-step speed reference 1	Multi-Fct Command 1	Combination of multi-step speed references 1, 2 correspond to speed reference (master speed An-01) and speed references 2 to 4 (An-02 to 04). Refer to "SYSTEM CONSTANT MULTI-STEP SPEED REFERENCE LIST"
04	Multi-step speed reference 2	Multi-Fct Command 2	
05	Note used	Reserved	
06	Jog frequency reference select	JOG Command	Closed: Jog frequency reference is selected.
07	Accel / decel time select	Acc. & Dec. Switch	Open: Accelerates / decelerates with ACCEL time 1 and DECEL time 1. (Bn-01, Bn-02 set values) Closed: Accelerates / decelerates with ACCEL time 2 and DECEL time 2. (Bn-03, Bn-04 set values)
08	External baseblock (NO-contact input)	Ext. B.B. NO-Cont.	Closed: Inverter output is shut off. (Frequency reference is held.)
09	External baseblock (NC-contact input)	Ext. B.B. NC-Cont.	Open: Inverter output is shut off. (Frequency reference is held.)
0A	Accel / decal speed prohibit command (HOLD command)	Inhibit Acc. & Dec.	Frequency reference is held. (SFS operation is stopped.)
0B	Inverter overheat alarm	Over Heat Alarm	Closed: Over Heat OH2 blinks on operator and operation continues. (Minor fault)

Set Value	Function	LCD display (English)	Description
0C to 0F	Not used	Reserved	-
10	UP command	UP command	Closed: Output frequency increment
11	DOWN command	DOWN command	Closed: Output frequency decrement
12	FJOG command	Forward Jog	Closed: Forward jog run FWD LED lights. Display: 6Hz
13	RJOG command	Reverse Jog	Closed: Reverse jog run Digital operator REV LED does not light. Display: 6 Hz
14 to 1F	Not used	Reserved	-
20 to 2F	External fault 5	External fault 5	External fault signal input
30 to 3F	External fault 6	External fault 6	
40 to 4F	External fault 7	External fault 7	
50 to 5F	External fault 8	External fault 8	
60	DC injection braking command (JOG with priority)	DC Braking Command	Closed: DC injection braking applied when the frequency output is less than the DC injection start frequency and the DC injection braking command is closed.
61	Search 1	Max. Freq. Sp_Search	Closed: Search from max frequency
62	Search 2	Set Freq. Sp_Search	Closed: Search from set frequency
63~64	Not used	Reserved	-
65	Integral value reset	I_Time Reset	Closed: Integral value reset at PID Control
66	PID control cancel	PID Invalid	Closed: PID control canceled
67*	PID sleep control cancel	PID sleep Invalid	Closed: PID sleep control canceled
68	Not used	Reserved	-

Setting error (OPE03) occurs by setting to Sn-15 to -18 in the following cases.

- When set values are not listed from the smaller to the larger.
- When more than two search references of set values 61, 62 and 64 are set simultaneously.

When the following combination is set at Sn-15 to -18, set value fault (OPE03) occurs.

- Set values are not in a descending order.
- More than two search commands of set values 61 and 62 are set.
- UP/DOWN commands are not set simultaneously (only one command can be set.)
- UP/DOWN and accel/decel prohibit commands are set simultaneously
- More than two set values except FF are set.

\*Sn-15~18=67, PID sleep control disabled, added from version 0307. LCD display "Reserved"

## 1 FWD/REV run select (set value = 00)

- When 0 is set in Sn-15, the mode becomes 3-wire sequence mode.

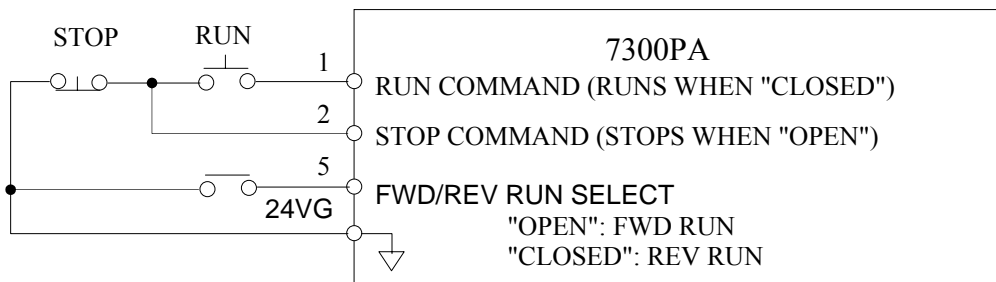

**Fig. 12 3-wire sequence**

## 2 Operation signal select (set value = 01)

- Selection of operation signals is enabled only stopping.

Open: The inverter operates according to the setting of Sn-04 1st, 2nd digits and Sn-08 1st, 2nd digits.

Closed: The inverter operates by frequency reference and run command from digital operator.

## &lt; Example 1 &gt;

For local/remote mode select, set Sn-04 = × × 00 and Sn-08 = × × 11.

Open: Frequency reference and run command of control circuit terminals are accepted (Remote mode).

Closed: Frequency reference and run command of the digital operator are accepted (Local mode).

## &lt; Example 2 &gt;

For local/remote mode select, set Sn-04 = × × 00 and Sn-08 = × × 00.

Open: Frequency reference and run command input by RS-485 communication option card (Remote mode).

Closed: Frequency reference and run/stop command input by digital operator (Local mode)

## 3 Option card/inverter reference select (set value = 02)

- Specify which of the option or inverter references is used for operation. The option/inverter selection is effective only during stopping.

Open: Option card frequency reference and operation signals are accepted.

Closed: Frequency reference and operation signals from the inverter control circuit terminals or the digital operator are accepted.

## 4 Selection of multi-step speed references 1 to 3 and jogging frequency select (set values = 3 to 6)

- Up to nine step speeds can be selected by combinations of multi-step speed references and jog frequencies.

: Closed × : Open - : No relation

Jog Frequency Reference Select	Multi-step Reference			Frequency Reference
	3	2	1	
×	×	×	×	Master speed frequency reference*
×	×	×		Auxiliary analog reference
×	×		×	Frequency reference 3 (An-03)
×	×			Frequency reference 4 (An-04)
×		×	×	Frequency reference 5 (An-05)
×		×		Frequency reference 6 (An-06)
×			×	Frequency reference 7 (An-07)
×				Frequency reference 8 (An-08)
	-	-	-	Jog frequency reference 3 (An-09)

\* In operator mode (1st digit of Sn-04 is 1), frequency reference 1 (An-01) is enabled.

When the multi-function analog input is selected by functions other the frequency reference (Sn-19=0), frequency reference 2 (An-02) becomes effective. When the multi-function analog input is not used, set F to the set value.

- For multi-step speed operation with frequency reference by keypad, perform the following setting:

- 1 Sn-04 = ×××1 An-01 becomes effective.
- 2 Sn-19 ≠00 An-02 becomes effective.

##### 5 Accel/decel time select (select value = 07)

- Accel/decel time is switched when "closed". Switching is permitted even during acceleration or deceleration.

Open: The accel/decel time set by gn-01 and Sn-02 is

Closed: The accel/decel time set by Sn-03 and 13n-04 is accepted.

##### 6 External baseblock (set value = 08)

- Baseblock is performed when "closed". External baseblock differs as follows depending on the input status of run command:
- When an external baseblock signal is input during running, "Ext. Baseblock bb" blinks at the digital operator and inverter output is shut OFF. When the external baseblock signal disappears, the inverter restarts with the frequency reference at that time. The voltage returns to the set value in the voltage recovery time. When a stop signal is input and an external baseblock signal is input while the inverter is decelerating, "Ext. Baseblock bb" blinks at the digital operator, the inverter output is shut OFF, and the output frequency is set to 0Hz.

## 7 External baseblock (set value = 09)

- Baseblock is performed when "open". All other operations are the same as when a set value = 8.

## 8 Accel/decel speed prohibit command (set value = 0A)

- As long as accel/decel speed prohibit command is input, accel/decel speed is prohibited and the output frequency at that time is held. When stop command is input, accel/decel speed prohibit state is freed and the system enters stop state. The figure below shows a time chart.

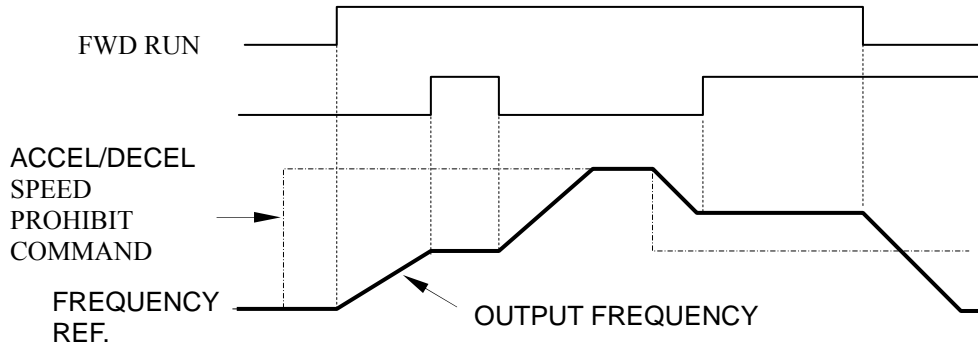

Note: If the run command is input again after the stop command is input while the accel/decel prohibit command is input, the holding output frequency is stored unless the accel/decel prohibit command is released. Therefore, operation is performed at the stored output frequency. Also when the power supply is turned OFF in the accel/decel prohibit command input status, the holding output frequency is still stored.

## 9 Inverter overheat alarm (set value = 0B)

- As long as an inverter overheat signal is input, "Over Heat OH2" blinks a the digital operator.

## 10 UP command/DOWN command (set value = 10, 11)

- Acceleration/deceleration is performed by inputting the UP/DOWN commands without changing frequency reference in the forward (reverse) run command input status, and operation can be performed at a desired speed.

Set value = 10: UP command

Set value = 11: DOWN command

UP command	Closed	Open	Open	Closed
DOWN command	Open	Closed	Open	Closed
Status	Accel (UP)	Decel (DOWN)	Hold	Hold

- The follow shows the time chart when the UP/DOWN commands are used.

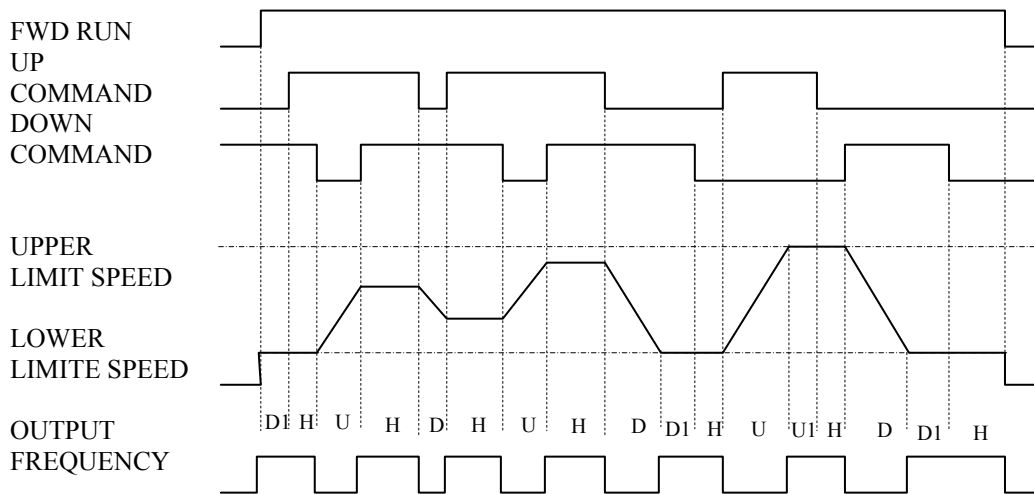

- U = UP (accel) status
- D = DOWN (decel) status
- H = HOLD (constant speed) status
- U1 = During clamp at upper limit speed even in UP status
- D1 = During clamp at lower limit speed even in DOWN status

Notes:

- When the UP/DOWN commands are used, set the Sn-04 1st digit. (frequency reference selection) as shown below.  
Set 1st digit = 0 without fail. .  
Setting 1st digit = 1 disables the UP/DOWN commands.
- When the UP/DOWN commands are selected, upper limit speed is set disregarding frequency reference.  
Upper limit speed = maximum output frequency (Cn-02) × frequency reference lower limit (Cn-14)
- The largest value among minimum output frequency (Cn-07), frequency reference lower limit (Cn-15) and main frequency reference input from control circuit terminal VIN or AIN is employed as lower limit speed.
- By inputting the FWD/REV run commands, operation is started at the lower limit speed even if the UP/DOWN command are not input.  
When the power supply is turned OFF in the HOLD status, the held output frequency is stored. Therefore, by inputting the FWD/REV run commands in the HOLD status continuously after the power supply is tuned ON, operation is performed at the stored output frequency.
- When the jog run command is input during running by UP/DOWN commands, the jog run command has priority.

## 11 FJOG command, RJOG command (set value = 12, 13)

- Forward and reverse jog frequency operation is enabled.

Set value = 12 FJOG command: Forward run by jog frequency reference (An-09) at closed.

Set value = 13 RJOG command: Reverse run by jog frequency reference (An-09) at closed.

## Notes:

1. When FJOG command or RJOG command is input during running, FJOG command or RJOG command has priority
2. When both FJOG and RJOG commands are closed for 500 ms or more, the inverter stops according to the stopping method selection (Sn-04).
3. FJOG or RJOG command can be set individually.

## 12 External faults 5 to 8 (set values = 2X, 3X, 4X, 5X: X is 0 to F)

- When external faults 5 to 8 are input, Ext. Fault 5 to 8 (EF5 to EF8) is displayed at the digital operator, and the inverter operates according to combinations of four bits shown in the table below. The hexadecimal equivalent of combinations of four bits shown below is set in the 1st digit of the setting value (2X, 3X, 4X, 5X) of external faults 5 to 8.

Bit No.	0	1
0	External fault input: NO - contact input	External fault input: NC - contact input
1	External fault signal: Always detected	External fault signal: Detected during running only
3, 2	Selection of processing at external fault detection	00: Ramp to a stop (major fault) 01: Coasting to a stop (major fault) 10: Ramp to a stop by bn-04 (major fault) 11: Operation to continue (minor fault)

<Example> External fault 5 is set to as follows :

- NO-contact input (from terminal 5)
- Signal is always detected
- Processing is coasting to a stop

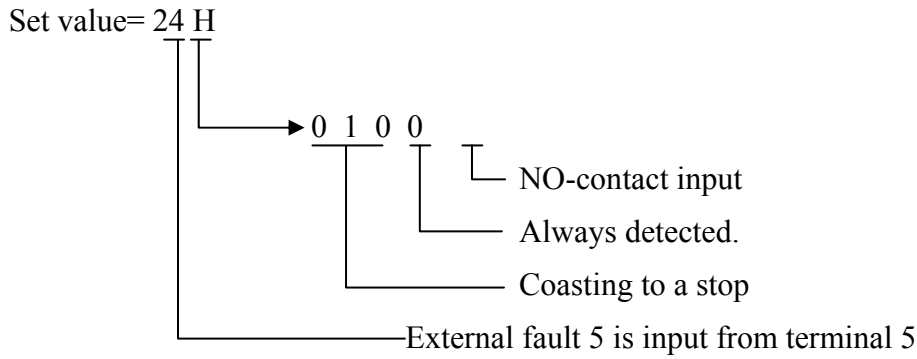

The inverter operates differently as described below when Experiencing major faults or minor faults. The digits in the error display Ext. Fault 5 to 8 (EF5 to EF8) indicate the terminal numbers in which external faults 5 to 8 are set.

### Major faults

If an external fault is input, the fault is displayed and the inverter stops according to process selection at external fault detection. Fault contact output relay is output immediately.

### Minor faults

Fault display blinks only when external fault is input (the display is made for 0.5 second even when input is less than 0.5 second).

<Example> External faults 5 to 8 are set to multi-function terminals 1 to 4 (Nos. of terminal 5 to 8)

No. of Fault	Multi-function Terminal	Display of Digital Operator	
		(Major Fault)	(Minor Fault) Blinking
External Fault 5	Terminal 5	Ext. Fault 5 (Fault EF5)	Ext. Fault 5 (Alarm EF5)
External Fault 6	Terminal 6	Ext. Fault 6 (Fault EF6)	Ext. Fault 6 (Alarm EF6)
External Fault 7	Terminal 7	Ext. Fault 7 (Fault EF7)	Ext. Fault 7 (Alarm EF7)
External Fault 8	Terminal 8	Ext. Fault 8 (Fault EF8)	Ext. Fault 8 (Alarm EF8)

### Additional Notes of External Faults

- External fault reset is enabled in baseblock status.
- The following shows the priority order of process selection when more than one external fault is input.  
Coasting to a stop > ramp to a stop by bn-04 > ramp to a stop by Bn-02
- Fault retry is disabled when an external fault is input.

## 13 DC injection braking command (set value = 60)

- When DC braking command is input when the inverter stops, DC braking operation is performed. When operation signal or jog operation command is input, the DC braking operation is stopped and the operation is started. (Privileged operation)

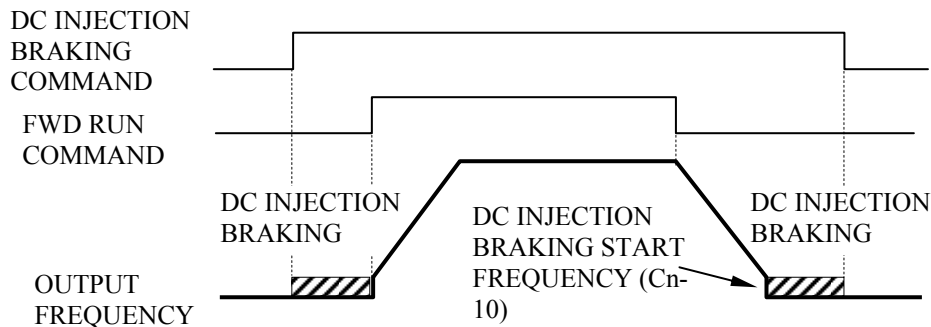

## 14 Search command (set value = 61,62)

- To start the motor during coasting when commercial power supply/inverter changing operation is performed, the motor can be operated without tripping by using the speed search function.

Set value = 61: Speed search starts with the maximum frequency.

Set value = 62: Speed search starts with the frequency reference value when search command is input.

- Search commands with set values of 61 and 62 cannot be set at the same time.
- By inputting the run command with the search command "closed" during baseblock, speed search starts after shutting down the inverter output for the minimum baseblock time (Cn-40).
- Speed search operation starts when inverter output current is larger than the set value of the speed search operation level (Cn-38), Frequency at which inverter output current is smaller determined as speed synchronous point: Re-acceleration/deceleration is performed in the set accel/decel time up to the set frequency.
- The following shows the time hart where the speed search command is input.

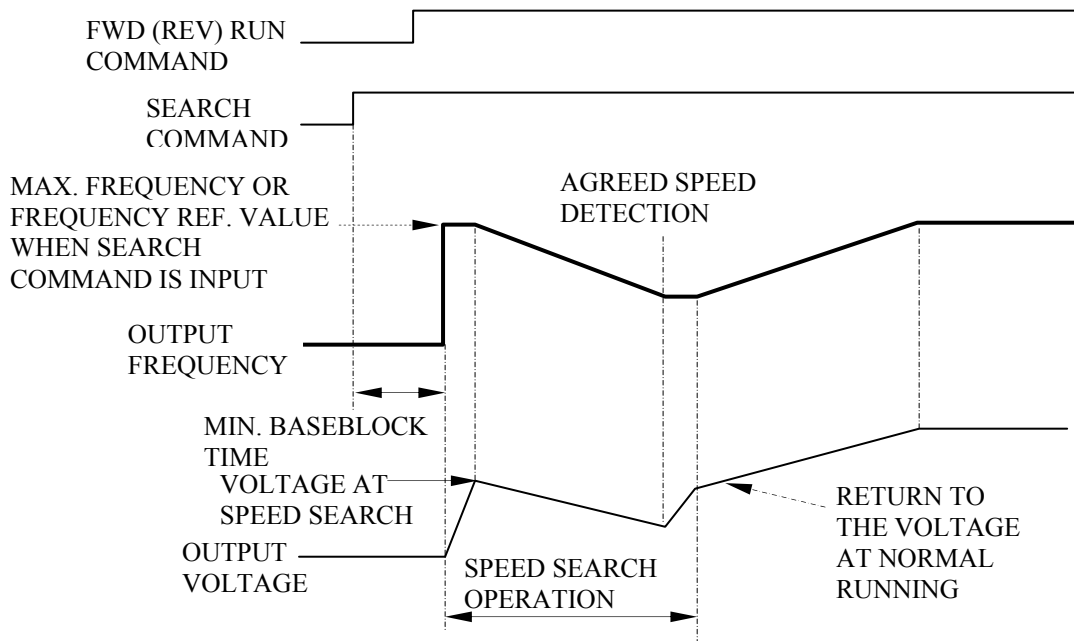

## Notes:

1. In momentary power loss operation continuation mode, speed search operation is performed beginning with current output frequency, regardless of the existence of search command. After completion of speed search, the operation is performed according to the run command.
2. Determine a sequence so that FWD/REV run command enters at the same time or later than search command.

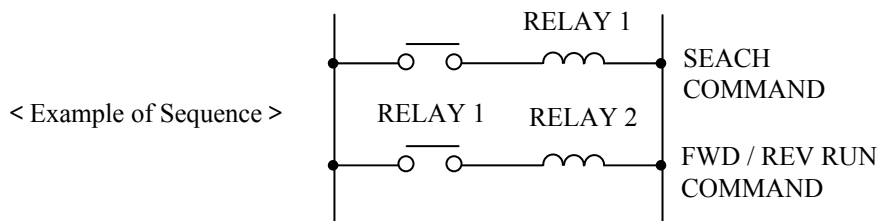

3. More than two search commands of set values 61 and 62 cannot be set.

## 15 Integral value reset (set value = 65)

- Value I is reset to 0 when an integral value reset command is input from multifunction contact inputs (terminal 5 ~ 8, set 65 either to Sn-15 to 18)

## 16 PID control cancel (set value = 66)

- PID control circuit can be canceled by multifunction contact input signal. Set 66 either to Sn-15 to 18 and close the contact (either terminal 5 to 8) during running. Then the PID control circuit is canceled and the aimed value signal is used as a frequency reference signal without being changed. In this case, the signal input level is 0 the 10V (or 4 to 20mA)/0 to 100%.

**(16) Multi-Function Analog Input Selection (Sn-19)**

- The settings and functions for the multi-function analog input (terminal AUX) are listed as below.

Set Value	Function	LCD display (English)	Remarks
00	AUX frequency reference*	Auxiliary Freq. Cmd.	Used for MASTER/AUX frequency reference selection
01	Frequency reference gain (F GAIN)	~ Freq. Cmd. Gain	Total gain: Internal gain (bn-05) × F GAIN
02	Frequency reference bias 1 (F BIAS 1)	Cmd. Bias 1	Total bias: Internal bias (bn-06) + F BIAS 1
03	Frequency reference bias 2 (F BIAS 2) (+ -)	Cmd. Bias 2	Total bias: Internal bias (bn-06) + F BIAS 2
04	Overtorque detection level	Over Tq. Level	Internal over torque detection level (Cn-26) ineffective
05	V BIAS †	V/F curve Bias	V BIAS addition after V/F conversion
06	Accel/decel time reduction coefficient	Acc. & Dec. Coeff.	Accel/decel time varied by analog input
07	DC braking current	DC Braking current	DC injection braking current varied by analog input (10 V/inverter rated current) Internal DC braking current setting (Cn-11) ineffective
08	Stall level during running	Run stall Level	Stall level during running is set by analog input. Cn-30 becomes ineffective.
09	PID control selection	PID Command	PID control performed
0A	Frequency reference lower limit	Freq. Cmd. Low Bound	Frequency reference lower value is set by analog input. (Either Cn-15 set value or analog input whichever is larger becomes effective.)
0B	Setting prohibit frequency 4	Freq. Jump 4	Set prohibit frequency is set. (The fourth value in addition to frequency values set by Cn-16 to 18 can be set)
0C	Motor overheat protection	Motor OH protect	Motor temperature sensor PTC thermistor connected to terminal MT-AUX and GND. Motor overheat protection active when the resistor of PTC thermistor 1330Ω, return when 550Ω
0D~0F	Not used	Reserved	-

\* Not to be used with An-02

440 class: V BIAS value 0 to 200 V.

Note: For combinations of multi-step speed references at set value = 00. refer to pages 2-46 and 2-47.

Multi-function Analog Input Characteristics

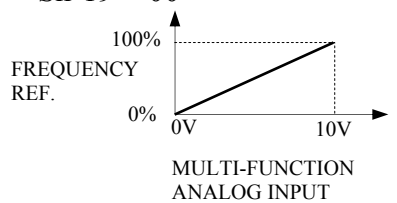
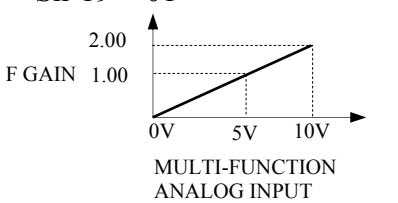
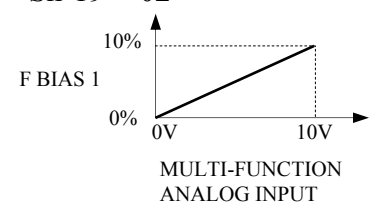
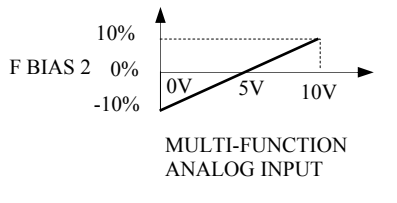
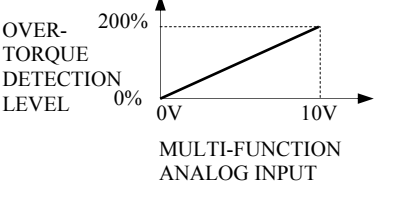
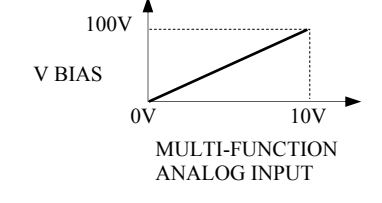
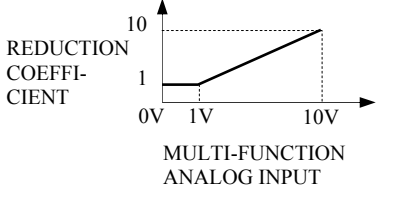
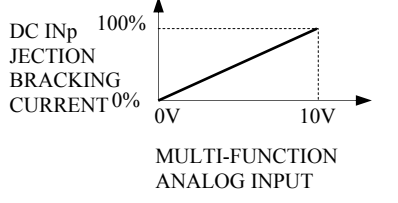
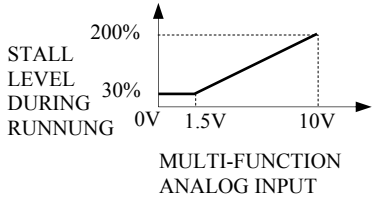
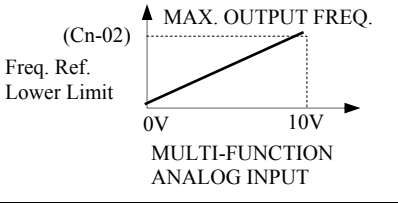
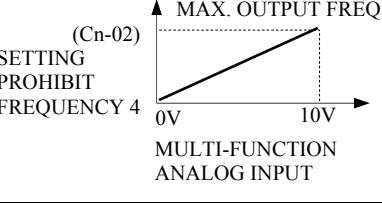
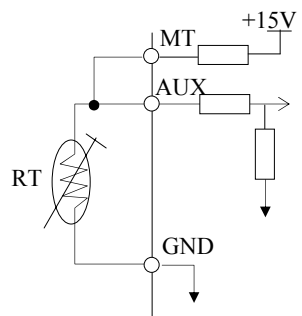
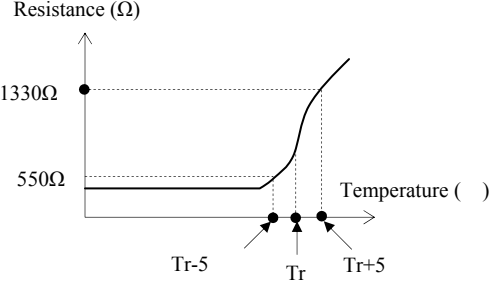
<p>1 Sn-19 = 00</p>  <p>FREQUENCY REF.</p> <p>MULTI-FUNCTION ANALOG INPUT</p>	<p>2 Sn-19 = 01</p>  <p>F GAIN</p> <p>MULTI-FUNCTION ANALOG INPUT</p>	<p>3 Sn-19 = 02</p>  <p>F BIAS 1</p> <p>MULTI-FUNCTION ANALOG INPUT</p>												
<p>4 Sn-19 = 03</p>  <p>F BIAS 2</p> <p>MULTI-FUNCTION ANALOG INPUT</p>	<p>5 Sn-19 = 04</p>  <p>OVER-TORQUE DETECTION LEVEL</p> <p>MULTI-FUNCTION ANALOG INPUT</p>	<p>6 Sn-19 = 05</p>  <p>V BIAS</p> <p>MULTI-FUNCTION ANALOG INPUT</p>												
<p>7 Sn-19 = 06</p>  <p>REDUCTION COEFFICIENT</p> <p>MULTI-FUNCTION ANALOG INPUT</p> <p>Actual accel/decel time = <math>\frac{\text{Accel/decel time (Bn-01 04)}}{\text{Reduction coefficient}}</math></p>	<p>8 Sn-19 = 07</p>  <p>DC INp JECTION BRACKING CURRENT</p> <p>MULTI-FUNCTION ANALOG INPUT</p>	<p>9 Sn-19 = 08</p>  <p>STALL LEVEL DURING RUNNUNG</p> <p>MULTI-FUNCTION ANALOG INPUT</p>												
<p>10 Sn-19 = 09</p> <p>multi-function analog input (terminal be used as the setting of PID control aimed values (0~10V input))</p>	<p>11 Sn-19 = 0A</p>  <p>(Cn-02) MAX. OUTPUT FREQ. Freq. Ref. Lower Limit</p> <p>MULTI-FUNCTION ANALOG INPUT</p>	<p>12 Sn-19 = 0B</p>  <p>(Cn-02) MAX. OUTPUT FREQ. SETTING PROHIBIT FREQUENCY 4</p> <p>MULTI-FUNCTION ANALOG INPUT</p>												
<p>13 Sn-19 = 0C</p> <ul style="list-style-type: none"> <li>The motor temperature detected sensor (PTC thermistor) <math>R_T</math> connected to terminal MT-AUX and GND.</li> <li>The motor overheat protection active when <math>R_T = 1330\Omega</math> and the delay time is over the motor overheat protection time (Cn-63), digital operator will display “Motor Overheat OH3” alarm and inverter stop the motor depend on the stopping method set in 3rd and 4th digits of Sn-12 and the fault contact signal is output.</li> <li>The motor overheat (OH3) alarm can be reset when <math>R_T = 550\Omega</math>.</li> <li>The typical characteristic of PTC thermistor <math>R_T</math> must follow the British Standard: <table style="margin-left: 20px;"> <tr> <td>Tr - 5</td> <td>: RT</td> <td>550Ω</td> </tr> <tr> <td>Tr + 5</td> <td>: RT</td> <td>1330Ω</td> </tr> <tr> <td>Tr - 20</td> <td>: RT</td> <td>250Ω</td> </tr> <tr> <td>Tr + 15</td> <td>: RT</td> <td>4000Ω</td> </tr> </table> </li> </ul> <div style="display: flex; justify-content: space-around; align-items: center;">   </div>			Tr - 5	: RT	550Ω	Tr + 5	: RT	1330Ω	Tr - 20	: RT	250Ω	Tr + 15	: RT	4000Ω
Tr - 5	: RT	550Ω												
Tr + 5	: RT	1330Ω												
Tr - 20	: RT	250Ω												
Tr + 15	: RT	4000Ω												

**(17) Multi-Function Contact Output Selection (Sn-20~Sn-22)**

Select the set values shown below for Sn-20 to -22.

Contact output for 0.1 sec. while detecting signal.

Terminal No	Sn- [ ][ ]
Control circuit terminal R2A-R2C (Contact output)	Sn-20
Control circuit terminal D01-DCOM (Open collector output)	Sn-21
Control circuit terminal R1A-R1C (Open collector output)	Sn-22

Set Value	Function	LCD display (English)	Description
00	During running	Running	Closed: During running
01	Zero speed	Zero speed	Closed: Zero speed
02	Agreed frequency	Frequency Arrive	Closed: $\left\{ \begin{array}{l} \text{Frequency ref.} \\ - \text{Cn-22} \end{array} \right\}$ Output Frequency $\left\{ \begin{array}{l} \text{Frequency ref.} \\ + \text{Cn-22} \end{array} \right\}$
03	Agreed frequency setting	Agreed F Arrive	Closed: Set value 2 in agreed frequency status and (Cn-21 - Cn-22) output frequency (Cn-21 + Cn-22)
04	Frequency detection 1	Freq. Det. 1	Closed: Output frequency Cn-32
05	Frequency detection 2	Freq. Det. 2	Closed: Output frequency Cn-33
06	Inverter operation ready	Run Ready OK!	Closed: Inverter operation ready
07	During undervoltage detection	Low Volt Detect	Closed: During undervoltage detection
08	During baseblock	Output B.B.	Closed: During inverter output baseblock
09	Frequency reference mode	Ref. Cmd. Operator	Open: From control circuit terminal Closed: From operator
0A	Control command	Run Source Operator	Open: From control circuit terminal Closed: From operator
0B	Overtorque detection	Over Tq. Detect	Closed: During overtorqucy reference missing
0C	Frequency reference missing	Freq. Cmd. Missing	Closed: While frequency reference missing
0D	Not used	Reserved	-
0E	Fault	Fault	Closed: Fault (except CPF 00, CPF 01)
0F	Not used	Reserved	-

## 1 Operation (set value=0)

- The operation contact is "closed" when FWD or REV run command is input, or the inverter outputs voltage.

## 2 Zero-speed (set value=1)

- The zero-speed contact is "closed" when inverter output frequency is less than the minimum output frequency.

## 3 Agreed frequency (set value=2)

- This is "closed" when output frequency is within the detection width shown in the figure below.

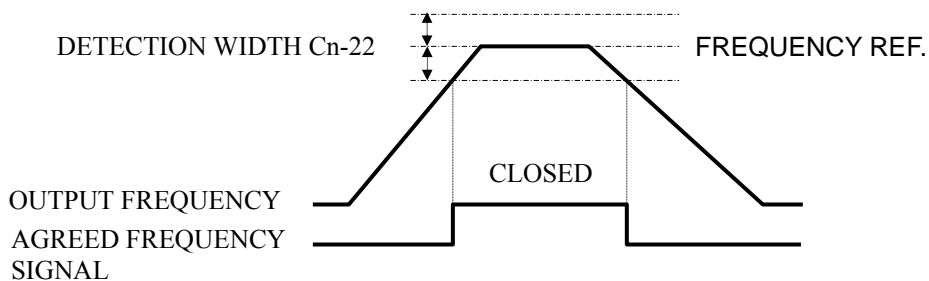

(Frequency ref. - Cn-22)    Output frequency    (Frequency ref. + Cn-22)

Cn-22: Agreed frequency detection width

## 4 Agreed frequency (Set value=3)

- This is "closed" when acceleration or deceleration is completed and output frequency is within the detection width shown in the figure below.

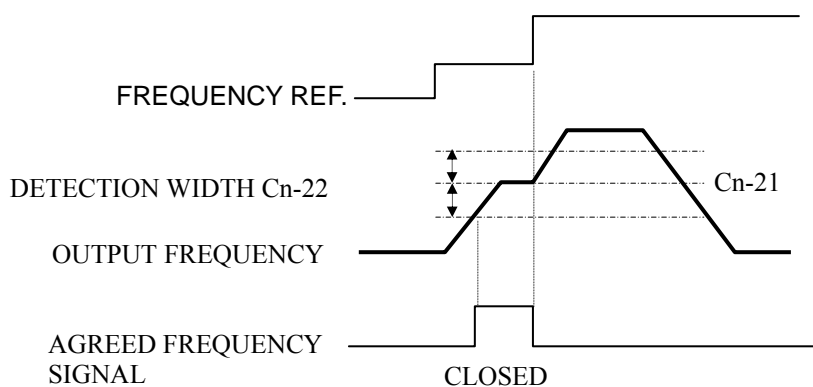

(Cn-21 - Cn-22)    Output frequency    (Cn-21 + Cn-22)

Cn-21: Agreed frequency point

Cn-22: Agreed frequency detection width

## 5 Frequency detection (set value=4)

- This contact is "closed" when output frequency is equal to or less than Cn-32, as shown in the figure below.

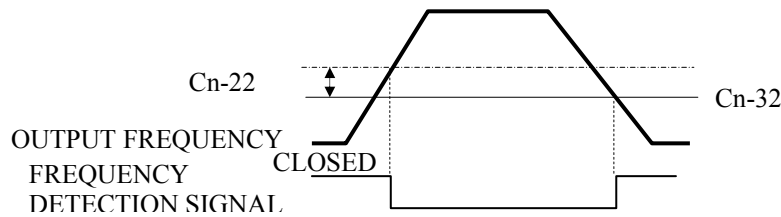

Output frequency Cn-32

Cn-32: Frequency detection 1 level

Cn-22: Agreed frequency detection width

## 6 Frequency detection (set value=5)

- This contact is "closed" when output frequency is equal to or greater than Cn-33, as shown in the figure below.

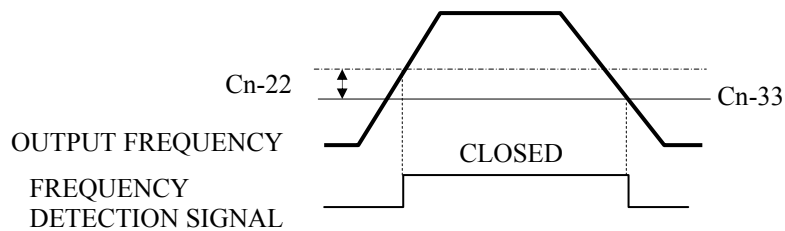

Output frequency Cn-33

Cn-33: Frequency detection 2 level

Cn-22: Agreed frequency detection width

## 7 Inverter operation ready (set value=6)

- This is "closed" when the inverter has become ready for operation.

## 8 During undervoltage (UV) detection (set value=7)

- This contact remains "closed" as long as the inverter is detecting undervoltage.

## 9 During baseblock (set value=8)

- This contact is always "closed" when inverter output is shut OFF.

## 10 Frequency reference mode (set value=9)

- This contact is "closed" when the frequency reference mode from the operator is selected.

## 11 Control command (set value=A)

- This contact is "closed" when the control command from the keyboard is selected.

## 12 Overtorque detection (set value=B)

- This contact remains "closed" as long as the inverter is detecting overtorque. Set overtorque detection level in Cn-26 and set overtorque detection time in Cn-27.

## 13 Frequency reference missing (set value=C)

- This is "closed" when frequency reference missing is detected.

## 14 Not used (set value= D)

## 15 Fault (set value=E)

- This contact is "closed" when the inverter detects a major fault. However, in the event of a fault in the watchdog (OP Commu. Error 1 CPF00) or transmission between the mainframe and operator, the inverter is not operated.

## 16 Not used (set value=F)

- Set F in multi-function contact output not used.

**(18) Inverter station address (Sn-23)****(19) RS-485 Communication protocol setting (Sn-24)**

- The 7300PA inverter has two RS-485 communication option card PA-M (MODBUS protocol) and PA-P (PROFIBUS protocol). These two option cards can be used for monitoring inverter status, reading the parameter setting, and changing the parameter setting to control the inverter operation.
- Parameter definition is as follows:

Sn-23 : Inverter station address, setting range 1~31.

Sn-24=

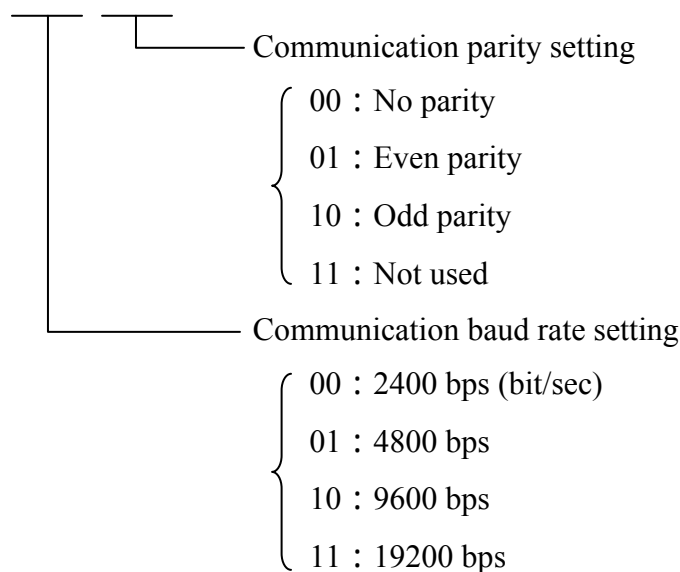

- Every data has a data length of 11 bits: 1 start\_bit, 8 data\_bits, 1 parity\_bit and 1 stop\_bit. If communication parity setting as no parity (Sn-24=XX00), the parity\_bit is 1.
- 3 different commands are used for communication between the inverter and external units:
  - a. Read Command external units to read the memory address of the inverter.
  - b. Write command external units to write the memory address of the inverter in order to control the inverter.
  - c. Circuit test command: To test the communication status between the inverter and external units.
- The change of setting Sn-23, Sn-24 will be effective in the next start time after turning off the inverter.
- Forbid the DRIVE/PRGM change while writing through RS-485.
- For more details of RS-485 communication refer to 「7300PA RS-485 MODBUS Communication Application Manual」 or 「7300PA RS-485 PROFIBUS Communication Application Manual」.

**(20) LCD Language displayed selection (Sn-25)**

- Sn-25 = 0 : English  
Sn-25 = 1 : Chinese

**(21) Multi-Function Analog Output A01 Function Selection (Sn-26)****(22) Multi-Function Analog Output A02 Function Selection (Sn-27)**

- The multi-function analog output A01 and A02 can be set to monitor the following 11 status items as shown below:

Sn-26, Sn-27 Setting	Monitored Contents (LCD Display)	Description	
		Input	Output
0	Frequency Command	0 ~ max. frequency	0 ~ 10V
1	Output Frequency	0 ~ max. frequency	
2	Output Current	0 ~ rated Current	
3	Output Voltage	0 ~ rated Voltage	
4	DC Voltage	220V: 0 ~ 400VDC 440V: 0 ~ 800VDC	
5	Output Power	0 ~ max. applicable motor capacity	
6	VIN Analog Command	0 ~ 10V	
7	AIN Analog Command	4 – 20mA	
8	AUX Analog Command	0 ~ 10V	
9	PID detected value (VIN + AIN)	0 ~ 10V	
10	Comm. Control	0 ~ 100%* <sup>1</sup>	

- The output gain Bn-11, Bn-12 will determine the output voltage at multi-function analog output at A01 and A02 terminal. The specified multiple of 10V will correspond to the 100% output monitored value.

\*1 : When Sn-26 ~ Sn-27=10, the multi-function output terminals A01, A02 are controlled by RS-485 commutation. Please ref. To “7300PA MODBUS/PROFIBUS application manual”.

**(23) Not Used (Sn-28)****(24) Not Used (Sn-29)**

**(25) Pump Operation Mode Selection (Sn-30)**

- The PA-PID option card application parameter. Set PA-PID card ineffective (Sn-30=0) when the PA-PID card is not installed. Please refer to “PA-PID instruction manual”.
- Sn-30=0 : PA-PID card ineffective.

Sn-30=1 : Fixed inverter driving mode, stop all the pumps by first-run-last-stop sequence. i.e. Only one of the pumps is driven by inverter, the others are driven by ac power source, and take the first run pump last stop sequence to stop all the pumps. This operation mode is better for the different motor KW application.

Sn-30=2 : Fixed inverter driving mode, stop the pump driven by the inverter only. i.e. When the inverter output the stop signal, only the pump driven by the inverter is stopped.

Sn-30=3 : Fixed inverter driving mode, stop all the pumps by first-run-first-stop sequence. i.e. The first-run (the motor running for the longest time) -first-stop sequence is adopted to stop the motors and it keeps the pumps have almost the same working duty. This operation mode is better for the same motor KW application.

Sn-30=4 : Cycled inverter driving mode, stop all the pumps by first-run-first-stop sequence. i.e. Except the auxiliary pumps, all the pumps are controlled by inverter, and take the first-run-first-stop sequence to stop all the pumps.

Sn-30=5 : Cycled inverter driving mode, stop the pump driven by the inverter only.

- Fixed inverter driving mode and Cycled inverter driving mode connection examples:

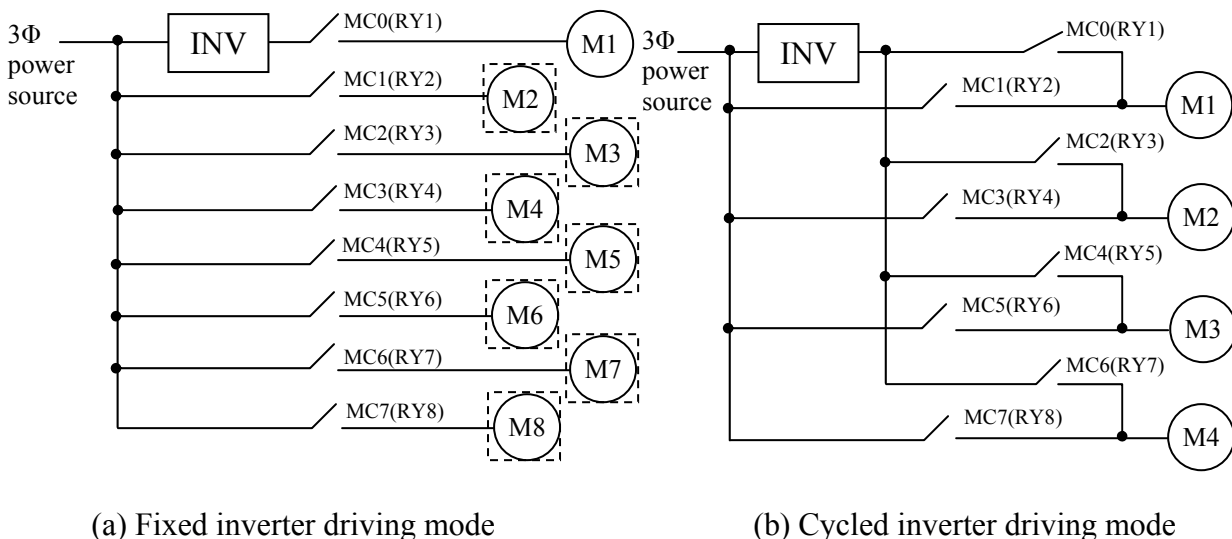

**Fig. 13 Pump Operation mode**

**(26) PA-PID Card Relay 2 Control (Sn-31)****(27) PA-PID Card Relay 3 Control (Sn-32)****(28) PA-PID Card Relay 4 Control (Sn-33)**

**(29) PA-PID Card Relay 5 Control (Sn-34)****(30) PA-PID Card Relay 6 Control (Sn-35)****(31) PA-PID Card Relay 7 Control (Sn-36)****(32) PA-PID Card Relay 8 Control (Sn-37)**

- The PA-PID option card application parameters. Please refer to “PA-PID instruction manual”.
- Used to control the pump ON/OFF.  
Sn-31 ~ 37=0 : Relay output invalid.  
Sn-31 ~ 37=1 : Relay output valid.

**(33) Parameter Copy (Sn-38)**

- JNEP-32 LCD digital operator can upload the parameter settings from the digital operator to inverter and download parameter settings from the inverter to the digital operator.
- The digital operator will check its EEPROM or the inverter's EEPROM under the following settings.
- Sn-38 = 0 : NO action  
Sn-38 = 1 : Upload data (digital operator → inverter). During this period, the LED on the digital operator will light sequentially in the CW sense.  
Sn-38 = 2 : Download data (inverter → digital operator). During this period, the LED on the digital operator will light sequentially in the CCW sense.  
Sn-38 = 3 : Verification check on digital operator's EEPROM; during this period the LED will be switch-on between 2 groups.
- Please follow the below steps to implement the action of parameter copy between different inverters (either upload or download).  
Step 1 : Check the contents of digital operator EEPROM. (Sn-38='03'), then check the contents of inverter's EEPROM (Sn-38='04'). Make sure that both EEPROM function properly.  
Step 2 : Download and copy the ' inverter's parameter settings to digital operator EEPROM (Sn-38=2).  
Step 3 : Upload and copy the parameter settings of digital operator to other inverter's EEPROM (Sn-38=1)

## 2.5 Monitoring Parameters Un -

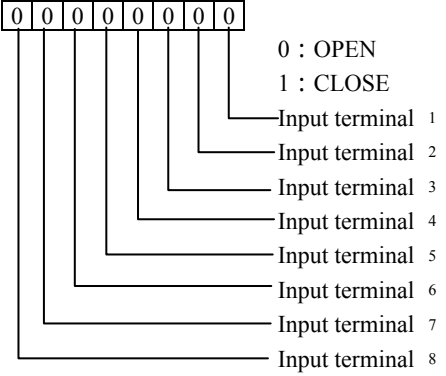
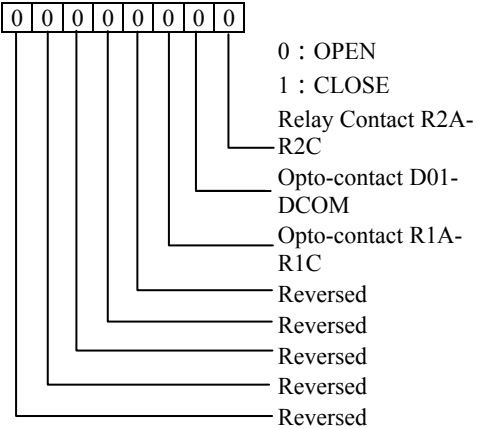
Parameter No.	Name	LCD Display (English)	Unit	Descriptions
Un-01	Frequency Command	Un-01=60.00Hz Frequency Command	0.01Hz	Display frequency command, the displayed unit is determined by Cn-20
Un-02	Output Frequency	Un-02=60.00Hz Output Frequency	0.01Hz	Display output frequency, the displayed unit is determined by Cn-20
Un-03	Output Current	Un-03=12.5A Output Current	0.1A	Display inverter output current
Un-04	Output Voltage	Un-04=220.0V Output Voltage	0.1V	Display output voltage command of inverter
Un-05	Main Circuit DC Voltage	Un-05=310.0V DC Voltage	0.1V	Display DC voltage of inverter main circuit
Un-06	Output Power	Un-06= KW Output Power	0.1KW	Display output power of inverter
Un-07	Output Power Factor	Un-07=0.90 Output P.F.	0.01	Display output power factor of inverter
Un-08	Input Terminal Status	Un-08=0000000 I/P Term. Status	-	 <p>0 : OPEN 1 : CLOSE Input terminal 1 Input terminal 2 Input terminal 3 Input terminal 4 Input terminal 5 Input terminal 6 Input terminal 7 Input terminal 8</p>
Un-09	Output Terminal Status	Un-09=0000000 O/P Term. Status	-	 <p>0 : OPEN 1 : CLOSE Relay Contact R2A-R2C Opto-contact D01-DCOM Opto-contact R1A-R1C Reversed Reversed Reversed Reversed</p>
Un-10	S/W Version	Un-10=00001 Software Version	-	- Manufacturing use -
Un-11	Motor Elapsed Run Hours	Un-11=00001Hr Elapsed Time	1Hr	Display total time elapsed after pressing RUN (display data is resettable)*1
Un-12	Motor Elapsed Energy KWHR	Un-12=00001Kwh Elapsed Energy	1Kwh	Display total motor output energy (display data is resettable)*1

Parameter No.	Name	LCD Display (English)	Unit	Descriptions
Un-13	Option card code	Un-13=0 None Opt. Card	1	0 : None of option card is installed 1 : PA-M, PA-L, PA-C card is installed in CN2. 2~5 : Reserved 6 : PA-P (PROFIBUS) card is installed in CN2. 7 : Reserved 8 : PA-PID card is installed in CN2.
Un-14	U phase current (IU) conversion value	Un-14=1.00V IU current	0.01V	Range : 0.00V ~ 5.00V ● Un-14, Un-15 can be used to check DCCT function. ● Un-16, Un-17 can be used to check ADC function in the control board. ● Troubleshooting used
Un-15	W phase current (IW) conversion value	Un-15=1.00V IW current		
Un-16	3 phase rectify current (DIAC) conversion value	Un-16=1.00V DIAC current		
Un-17	ADC Reference Volt. conversion value	Un-17=2.50V ADCHK Voltage		
Un-18	External Analog Command VIN	Un-18=10.00V Voltage ~ Input	0.01V	Range : 0.00V ~ 10.00V
Un-19	External Analog Command AIN	Un-19=20.0mA Current ~ Input	0.1mA	Range : 0.0 ~ 20.0mA
Un-20	Multi-Function Analog Input Command AUX	Un-20=10.00V Multi-Fct. ~ Input	0.01V	Range : 0.00V ~ 10.00V
Un-21	PID Detected Value after display unit conversion	Un-21=1.000 PID Detect	0.001	<p>Range : -9.999 ~ +9.999 The display conversion unit depend on Bn-21 and Bn-22.</p>

\*1 The contents of Un-11 and Un-12 can be reset by Sn-03=1000 and 1001 Individually.

\*2 The display status for JNEP-33 LED operator : \*3. The display status for JNEP-33 LED operator

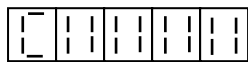

OFF: OPEN  
LIT : CLOSED

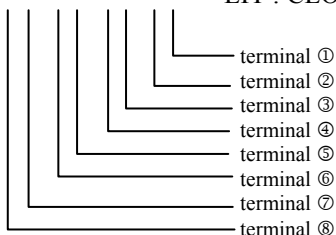

OFF: OPEN  
LIT : CLOSED

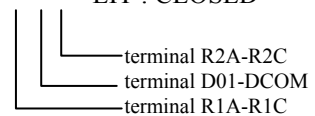

## 2.6 Monitoring Parameters Hn -

- The inverter input/output interface status can be monitored under the PRGM mode by Hn-parameter.
- Hn- parameter will toggle display with low voltage protection alarm (UV) if the UV alarm occurred.

Parameter No.	Name	LCD Display (English)	Unit	Descriptions
Hn-01	Main Circuit DC Voltage	Hn-01=622.0V DC Voltage	0.1V	Display DC voltage of inverter main circuit
Hn-02	Input Terminal Status	Hn-02=00000000 I/P Term. Status	-	<p>0 : OPEN 1 : CLOSE</p> <p>Input terminal 1 Input terminal 2 Input terminal 3 Input terminal 4 Input terminal 5 Input terminal 6 Input terminal 7 Input terminal 8</p>
Hn-03	Output Terminal Status	Hn-03=00000000 O/P Term. Status	-	<p>0 : OPEN 1 : CLOSE</p> <p>Relay Contact R2A-R2C Opto-contact D01-DCOM Opto-contact R1A-R1C Reversed Reversed Reversed Reversed</p>
Hn-04	Option card code	Hn-04=0 None Opt. Card	1	<p>0 : None of option card is installed 1 : PA-M, PA-L, PA-C card is installed. 2~5 : Reserved 6 : PA-P, PA-L, PA-C card is installed . 7 : Reserved 8 : PA-PID card is installed.</p>
Hn-05	U phase current (IU) conversion value	Hn-05=2.50V IU current	0.01V	<p>Range : 0.00V ~ 5.00V</p> <ul style="list-style-type: none"> <li>● Hn-05, Hn-06 can be used to check DCCT function.</li> <li>● Hn-07, Hn-08 can be used to check ADC function in the control board.</li> <li>● Troubleshooting used.</li> </ul>
Hn-06	W phase current (IW) conversion value	Hn-06=2.50V IW current		
Hn-07	3 phase rectify current (DIAC) conversion value	Hn-07=1.00V DIAC current		
Hn-08	ADC Reference Volt. conversion value	Hn-08=2.50V ADCHK Voltage		

Parameter No.	Name	LCD Display (English)	Unit	Descriptions
Hn-09	External Analog Command VIN	Hn-09=10.00V Voltage ~ Input	0.01V	Range : 0.00V ~ 10.00V
Hn-10	External Analog Command AIN	Hn-10=20.0mA Current ~ Input	0.1mA	Range : 0.0 ~ 20.0mA
Hn-11	Multi-Function Analog Input Command AUX	Hn-11=10.00V Multi-Fct. ~ Input	0.01V	Range : 0.00V ~ 10.00V
Hn-12	Motor Elapsed Run Hours	Hn-12=00001Hr Elapsed Time	1Hr	Display total time elapsed after pressing RUN (display data is resetable)
Hn-13	S/W Version	Hn-13=00001 Software Version	-	- Manufacturing use -

## 2.7 Order Parameters On-

- Order parameters are already set to the optimum value as initial values, adjustment is not needed in the normal status.

Function	Parameter NO.	Name	LCD Display (English)	Description	Factory Setting
Control Status	On-01	Control Status 1	On-01=0000 Control Status 1	XX0X : stored the frequency reference in the HOLD status (for up/down operation) XX1X : Do not store the frequency reference in the HOLD status	0000
	On-02	Control Status 2	On-02=0000 Control Status 2	XXX0 : Inverter overload protection (OL2) valid XXX1 : Inverter overload protection (OL2) invalid XX0X : AVR function valid XX1X : AVR function invalid	0000
	On-03	Control Status 3	On-03=0000 Control Status 3	XXX0 : Anti-hunting gain change depending on inverter output voltage XXX1 : Anti-hunting gain depending on On-07 setting XX0X : Two-phase PWM modulation XX1X : Three-phase PWM modulation X0XX : Power angle compensation bias change depending on inverter output frequency X1XX : Power angle compensation bias fixed	0000
	On-04	PID control mode selection	On-04=0000 Reserved	XXX0 : Bias D control XXX1 : Feedback D control XX0X : PID output forward characteristics control XX1X : PID output reversed characteristics control X0XX : Frequency command=PID output X1XX : Frequency command=PID output+ Frequency command 0XXX : Forward characteristics PID feedback 1XXX : Reversed characteristics PID feedback	0000
-	On-05	Not used	On-05=0 Reserved	-	0.00
	On-06	Not used	On-06=0 Reserved	-	0
Hunting Prevention control	On-07	Hunting Prevention gain	On-07=0.10 Hunt Prev. Gain	Setting range : 0.01 ~ 2.55	0.10
	On-08	Hunting Prevention limit	On-08=030% Hunt Prev. Limit	Setting range : 0 ~ 100%	30%*1
Effective current detection control	On-09	Effective current detection filter time constant	On-09=005 I_Det. Time const	Setting range : 1 (3.5ms) ~ 100 (350ms)	5*1 (17.5ms)
	On-10	Not used	On-10=0 Reserved	-	0
On-delay control	On-11	ON-DELAY TIME	On-11=011 ON-Delay Time	Setting range : 11 (2.75 $\mu$ s) ~ 160 (40 $\mu$ s), =0.25 $\mu$ s	11 (2.75 $\mu$ s)
	On-12	ON-DELAY Compensated value	On-12=014 ON-Delay Compen.	Setting range : 0 ~ 160 (40 $\mu$ s), =0.25 $\mu$ s	14 (3.5 $\mu$ s)
-	On-13	Not used	On-13=0 Reserved	-	0
	On-14	Not used	On-14=0 Reserved	-	0
Energy Saving power detection	On-15	Power detection filter changing width	On-15=010% Power Det. Dead Zone	Setting range : 0 ~100% Setting unit : 1%	10%
	On-16	Power detection filter time constant	On-16=020 Power Det. Time Const.	Setting range : 1 ~255 Setting unit : 1 (=7ms)	20 (140ms)

Function	Parameter NO.	Name	LCD Display (English)	Description	Factory Setting
Torque Boost Control	On-17	Motor phase to phase resistance	On-17=00.308Ω Motor Line R	Setting range : 0 ~ 65.535Ω Setting unit : 0.001Ω	0.308Ω* <sup>1</sup>
	On-18	Torque Compensation of care loss	On-18=425W Tq. Compens. Care Loss	Setting range : 0 ~ 65535W Setting unit : 1W	425W* <sup>1</sup>
	On-19	Torque Compensation limit	On-19=100V Tq. Compens. Limit	Setting range : 0 ~ 50V* <sup>2</sup> Setting unit : 1V	100V* <sup>1</sup>
Energy-saving Motor Constant *3	On-20	Motor Constant R1	On-20=00.000Ω Motor R1	Setting range : 0.000 ~ 65.535Ω Setting unit : 0.001Ω	0.000Ω
	On-21	Motor Constant R2	On-21=00.000Ω Motor R2	Setting range : 0.000 ~ 65.535Ω Setting unit : 0.001Ω	0.000Ω
	On-22	Motor Constant L	On-22=00.000mH Motor L	Setting range : 0.000 ~ 65.535mH Setting unit : 0.001mH	0.000mH
	On-23	Motor Constant Rm	On-23=00.000mΩ/ω Motor Rm	Setting range : 0.000 ~ 65.535mΩ/ω Setting unit : 0.001mΩ/ω	0.000mΩ/ω
	On-24	Motor Constant Lm	On-24=00.00mH Motor Lm	Setting range : 0.00 ~ 655.35mH Setting unit : 0.01mH	0.00mH

\*1. Factory setting differ depending on inverter capacity (Sn-01 set value).  
This example shown combination of TECO standard motor 440V, 60Hz, 25HP (18.5KW).

\*2. For 220V class, X2 for 440V class.

\*3. ● Setting can be made only when Cn-60=FFH. When the value is changed, K2 (Energy-saving Coefficient K2) is calculated and the calculated value is set to Cn-58.

- Motor constants (On-20 ~On-24) are not stored in NVRAM and become 0 at power startup.
- The unit and setting range change depending on the inverter capacity:  
1/10 for 220V class 25HP ~ 125HP, 440V class 75HP ~ 500HP.
- On-04 is available when Ver : 04××

### 3. FAULT DISPLAY AND TROUBLESHOOTING

The 7300PA has protection function and warning self-diagnosis function. If a fault occurs, the protection functions operate to shut off the inverter output and the motor coasts to a stop, at the same time, the fault contact signal (terminal R3A-R3C, R3B-R3C) is output.

#### A). PROTECTION FUNCTION AND TROUBLESHOOTING

Protection function		Explanation	LCD display (English)
Low voltage protection	Main circuit low voltage	When the inverter power voltage drops, torque becomes insufficient and motor is overheated. Inverter output is stopped when the main circuit DC voltage becomes lower than the low voltage detection level for 15 ms or longer. or about 2 seconds or longer if the momentary power loss redo-thru function is used. Detection level: Approximately 210V or less for 200V class and 420V or less for 400V class	Fault (UV1)* <sup>1</sup> DC Volt. Low
	Momentary power loss protection		
	Control circuit low voltage	The inverter output is shut-off when the control circuit voltage drops below the low voltage level.	Fault (UV2)* <sup>1</sup> Cont. Ckt Low Volt.
	Main circuit soft charge contactor defective	The inverter output is shut-off when no answer back is received from the main circuit soft-start contactor.	Fault (UV3)* <sup>1</sup> MC Ans. Fault
Overcurrent protection		The inverter output is shut-off when the inverter output current becomes approx. 200% and above of inverter rated current.	Fault (OC)* <sup>1</sup> Over Current
Ground-fault protection		The inverter output is shut-off when a ground-fault occurs at the inverter output side and the ground-fault current exceeds approximately 50% of the inverter rated current.	Fault (GF)* <sup>1</sup> Ground Short
Overvoltage protection		The inverter output is shut-off when the main circuit DC voltage becomes excessive because of regeneration energy caused by motor deceleration and negative load. Detection. Approx. 800V for input voltage set 400V and above Level : Approx. 700V for input voltage set 400V or less and approx. 400V for 200V class	Fault (OV)* <sup>1</sup> Over Voltage
Cooling fin overheat		The inverter output is shut-off when the ambient temperature rises and the heat sink fin reaches 105 °C. Please check for a defective cooling fan or clogged filter.	Fault (OH)* <sup>1</sup> Over Heat
Overload protection	Motor	Inverter output is stopped when motor overload is detected by the electronic thermal overload in the inverter. Either a inverter duty constant-torque specialized motor or general-purpose motor can be selected. If more than one motor is driven, overload protection should be disabled. Use a thermal relay or thermal protector for each motor.	Fault (OL1)* <sup>1</sup> Motor Over Load
	Inverter	The inverter output is shut-off when the electronic thermal overload reaches or exceeds the inverse time limit of 103% of the inverter's rated current occurs. Maximum rated overload: 110%. 1 min.	Fault (OL2)* <sup>1</sup> Inverter Over Load
	Over torque detection	The motor operates according to a preset mode when the inverter output current exceeds the overtorque detection level. This function is used to protect the machine or to monitor the output torque.	Fault (OL3)* <sup>1</sup> Over Torque
External fault signal input	Terminal 3	When an external alarm signal is input, the inverter operates according to a preset stop method (coasting to a stop, continuous operation, or ramp to stop)	Fault (EF3)* <sup>1</sup> External Fault 3
	Terminal 5		Fault (EF5)* <sup>1</sup> External Fault 5
	Terminal 6		Fault (EF6)* <sup>1</sup> External Fault 6
	Terminal 7		Fault (EF7)* <sup>1</sup> External Fault 7
	Terminal 8		Fault (EF8)* <sup>1</sup> External Fault 8
Control Circuit Fault	Control Circuit Fault	The inverter output is shut-off when a transmission error occurs in the control circuit or a component fails. The inverter output is also shut-off when a specialized option such as the digital operator is not properly connected.	Fault (CPF02)* <sup>1</sup> Cont.Ckt Fault
	EEPROM fault		Fault (CPF03)* <sup>1</sup> EEPROM Fault
	EEPROM BCC CODE Error		Fault (CPF04)* <sup>1</sup> EEPROM CODE Err.
	CPU ADC Fault		Fault (CPF05)* <sup>1</sup> A/D Fault
	Option Card Fault		Fault (CPF06)* <sup>1</sup> Opt. Card Improper

The warning and self-diagnosis functions do not operate fault contact output (except OH1 warning function) and returns to the former operation status automatically when the factor is removed.  
The fault display and troubleshooting are provided as shown in the table below.

Fault Contact output	Error causes	Action to be taken
Operation	<ul style="list-style-type: none"> <li>● Inverter capacity is too small.</li> <li>● Voltage drop due to wiring.</li> <li>● Inverter power voltage selection is wrong</li> <li>● A motor of large capacity (11 kW or greater) connected to the same power system has been started.</li> <li>● Rapid acceleration with generator power supply</li> <li>● Operation sequence when power is off</li> <li>● Defective electromagnetic contactor</li> </ul>	<ul style="list-style-type: none"> <li>● Check the power capacity and power system.</li> <li>● UV display appears when the inverter power is turned off while operation signal is input. Remove the power after stopping the inverter.</li> <li>● (Set the third and fourth bits of Sn-04 to 01.)</li> </ul>
Operation	<ul style="list-style-type: none"> <li>● Extremely rapid accel/decel</li> <li>● Motor on/off switching at the inverter output side</li> <li>● Short-circuit or ground-fault at the inverter output side</li> <li>● Motor of a capacity greater than the inverter rating has been started</li> <li>● High-speed motor or pulse motor has been started.</li> </ul>	Transistor error may occur. Investigate the error cause, correct it, then restart.
Operation	<ul style="list-style-type: none"> <li>● Motor dielectric strength is insufficient.</li> <li>● Load wiring is not proper.</li> </ul>	Check for ground-fault in motor or load wiring.
Operation	<ul style="list-style-type: none"> <li>● Over voltage</li> <li>● Insufficient deceleration time</li> <li>● Regenerative load (Motor is turned by the load.)</li> <li>● High input voltage compared to motor rated voltage</li> </ul>	If braking torque is not proper, extend the decel time or use a braking resistor. (If braking resistor is already installed, verify that Sn-10. 2nd digit to 1.)
Operation	<ul style="list-style-type: none"> <li>● Defective cooling fan.</li> <li>● Ambient temperature rise</li> <li>● Clogged filter</li> </ul>	Replace the cooling fan and clean the filter. Ambient temperature: 104 (40 ) or less for enclosed type 122 (45 ) or less for open chassis
Operation	Overload, low speed operation or extended acceleration time, improper V/f characteristic setting	Investigate the cause of overload and review the operation pattern, V/f characteristic, and motor/inverter capacities. (If inverter is repeatedly reset after an overload occurs, the inverter may fault. Investigate and correct the cause of overload.)
Operation	Motor current exceeds the preset value because of machine error or overload.	Check the use of the machine. Correct the overload cause or set a higher detection level which is within the allowable range.
Operation	External fault condition occurred.	Correct the Cause of the fault input.
Operation	<ul style="list-style-type: none"> <li>● External noise</li> <li>● Excess vibration or shock</li> <li>● CPF 02: Control circuit fault</li> <li>● CPF 03: NVRAM (SRAM) fault</li> <li>● CPF 04: NVRAM BCC Code error</li> <li>● CPF 05: AD converter fault in CPU</li> </ul>	Check data in Sn-01 and Sn-02. Record all data, then use, Sn-03 for initializing. Turn off power, then turn on again. If error is persistent, contact your TECO representative.

Protection function		Explanation	LCD display (English)
Parameter Setting Error		Parameter Setting Error	Fault (Err)* <sup>1</sup> Parameter
Input Phase Loss Fault		DC bus voltage ripple $V$ input phase loss detection level (Cn-61), the motor coasts to stop	Fault (SPi)* <sup>1</sup> Input phase loss
Output Phase Loss Fault		One of the inverter output phases are lost, the motor coasts to stop.	Fault (SPO)* <sup>1</sup> Output phase loss
Motor overheat		The motor temperature detected sensor PTC thermistor RT 1330 $\Omega$	Fault (OH3)* <sup>1</sup> Motor Overheat
RS-485 communication Fault	Fault 1	RS-485 communication error or transmission fault during communicating and the RS-485 stopping method after communication error of Sn-08 is to stop the motor.	(CPF21)* <sup>1</sup> Comm. Fault 1
	Fault 2	RS-485 communication protocol error and the RS-485 stopping method after communication error of Sn-08 is to stop the motor	(CPF22)* <sup>1</sup> Comm. Fault 2
	Fault 3	PROFIBUS communication option card PA-P Dual port RAM fault.	(CPF23)* <sup>1</sup> Comm. Fault 3
	Fault 4	PROFIBUS communication option card PA-P EEPROM checksum error.	(CPF24)* <sup>1</sup> Comm. Fault 4
	Fault 5	PROFIBUS communication option card PA-P RAM fault	(CPF25)* <sup>1</sup> Comm. Fault 5
	Fault 6	PROFIBUS communication option card PA-P communication IC fault.	(CPF26)* <sup>1</sup> Comm. Fault 6
	Fault 7	PROFIBUS communication option card PA-P Watch dog timer active.	(CPF27)* <sup>1</sup> Comm. Fault 7

\* 1. The display contents of LED digital operator.

Fault Contact output	Error causes	Action to be taken
Operation	Parameter setting error	
Operation	<ul style="list-style-type: none"> <li>● One of the inverter input phases are lost</li> <li>● 3 phases power source are unbalance.</li> <li>● The main circuit smooth capacitor are deteriorated.</li> <li>● Improper input phase loss detection level (Cn-61) setting</li> </ul>	<ul style="list-style-type: none"> <li>● Check the inverter input power supply wiring.</li> <li>● Check the capacitors.</li> <li>● Check the setting of Cn-61.</li> </ul>
Operation	<ul style="list-style-type: none"> <li>● One of the inverter output phases are lost</li> <li>● DCCT fault.</li> </ul>	<ul style="list-style-type: none"> <li>● Check the wiring between inverter and motor.</li> <li>● Replace the DCCT.</li> </ul>
Operation	<ul style="list-style-type: none"> <li>● Motor load current is too large.</li> <li>● The effective cooling of motor is not sufficient.</li> </ul>	<ul style="list-style-type: none"> <li>● Check the motor load current.</li> <li>● Check the motor effective cooling.</li> </ul>
Operation	<ul style="list-style-type: none"> <li>● RS-485 communication option card fault</li> <li>● Excess vibration or shock</li> <li>● External noise</li> </ul>	<ul style="list-style-type: none"> <li>● Turn off power, then turn on again. If error is persistent, replace the option card.</li> </ul>
Operation	<ul style="list-style-type: none"> <li>● The RS-485 communication protocols setting inverter (Sn-24) and option card are inconsistent.</li> </ul>	<ul style="list-style-type: none"> <li>● Check the setting in Sn-24 and option card.</li> </ul>
Operation	<ul style="list-style-type: none"> <li>● PA-P card fault</li> </ul>	<ul style="list-style-type: none"> <li>● Turn off power, then turn on again. If error is persistent, replace the option card.</li> </ul>
Operation		
Operation		
Operation		
Operation		

## B.) Warning and Self-Diagnosis Functions

Protection function		Explanation	LCD display (English)
Low-voltage protection ( main circuit insufficient ) voltage		Monitor display appears if low voltage protection conditions such as a drop in main circuit voltage or momentary power loss occur while the inverter output is off.	(blinking) Alarm (UV)* <sup>1</sup> DC Volt. Low
High voltage protection		Monitor display appears when the main circuit DC voltage rises above the detection level while the inverter output is off.	(blinking) Alarm (OV)* <sup>1</sup> Over Voltage
Cooling fin overheat warning		Monitor display appears when a separate thermal protector contact is input to the external terminal. (Sn-15 ~ 18 = OB)	(blinking) Alarm (OH2)* <sup>1</sup> Over Heat
Overtorque detection		This function is used to protect the machine and to monitor the inverter output torque. The inverter output reacts in a preset manner when the inverter output current exceeds the over torque detection level. The monitor display blinks when "operation continue" is preset.	(blinking) Alarm (OL3)* <sup>1</sup> Over Torque
Stall prevention ( Accel/decel is accomplished with maximum capacity of the inverter without tripping on over-current or overvoltage a )	During acceleration	Inverter acceleration is stopped when 150% of or more of the inverter rated current is required by the load. This prevents overload protection (OL2) or overcurrent (OC) from occurring. When current is reduced to less than 170%, acceleration is enabled.	-
	During normal operation	Output frequency is decreased when 130% of the inverter rated current or greater is required by the load. This prevents motor and inverter overload (OL1, OL2). When current is reduced below 130%, inverter acceleration is then enabled.	-
	During deceleration	Deceleration is stopped when the DC voltage is caused to rise by motor regenerative energy. This prevents overvoltage trips (OV). When DC voltage decreases, deceleration to the set value then resumes	-
Simultaneous normal and reverse rotation commands		When forward and reverse rotation commands are simultaneously detected for a period of time exceeding 500 ms, the inverter is stopped according to the preset stop method.	(blinking) Alarm (EF)* <sup>1</sup> Input Error
External Fault Signal Input (Minor fault)	Terminal 3	It is indicated on the monitor when the mode after external signal input is set to "Operation continue." ● Ref. to the external faults 5 ~ 8 setting on page 87 ● Minor fault setting - terminal 3 (Sn-12=11XX) terminal 5 (Sn-15=2C) terminal 6 (Sn-16=3C) terminal 7 (Sn-17=4C) terminal 8 (Sn-18=5C)	(blinking) Alarm (EF3)* <sup>1</sup> External Fault 3
	Terminal 5		(blinking) Alarm (EF5)* <sup>1</sup> External Fault 5
	Terminal 6		(blinking) Alarm (EF6)* <sup>1</sup> External Fault 6
	Terminal 7		(blinking) Alarm (EF7)* <sup>1</sup> External Fault 7
	Terminal 8		(blinking) Alarm (EF8)* <sup>1</sup> External Fault 8
Digital Operator communication error		Operator transmission fault 1 (Initial fault)	Alarm (CPF00)* <sup>1</sup> OP Comm. Fault
		Operator transmission fault 2 (on lime fault)	Alarm (CPF01)* <sup>1</sup> OP Comm. Fault 2

Fault Contact output	Error causes	Action to be taken
Non Operation	<ul style="list-style-type: none"> <li>● Input voltage drop</li> </ul>	Check the main circuit DC voltage in Un-xx. If the voltage is low, adjust the input voltage.
Non Operation	<ul style="list-style-type: none"> <li>● Input voltage rise</li> </ul>	Check the main circuit DC voltage in Un-xx. If the voltage is high, adjust the input voltage.
Non Operation	<ul style="list-style-type: none"> <li>● Overload</li> <li>● Cooling fan fault</li> <li>● Ambient temperature rise</li> <li>● Clogged filter</li> </ul>	Replace the cooling fan and clean the filter. Ambient temperature: 104 (40 ) or less for enclosed type 122 (45 ) or less for open chassis
Non Operation	<ul style="list-style-type: none"> <li>● Motor current exceeded the set value because of machine fault or overload.</li> </ul>	Check the driven machine and correct the cause of the fault or set to a higher value.
Non Operation	<ul style="list-style-type: none"> <li>● Insufficient power for accel/decel</li> <li>● Overload</li> <li>● Phase loss</li> </ul>	<ul style="list-style-type: none"> <li>● Set proper accel/decel time for smooth operation.</li> <li>● For stall prevention during normal operation lighten the load or increase inverter capacity.</li> </ul>
Non Operation	<ul style="list-style-type: none"> <li>● Operation sequence error</li> <li>● 3-wire/2-wire selection error</li> </ul>	<ul style="list-style-type: none"> <li>● Recheck the control sequence.</li> <li>● Recheck system constant (Sn-15 to -18)</li> </ul>
Non Operation	<ul style="list-style-type: none"> <li>● External fault conditions set-up</li> </ul>	Take appropriate measurement for the cause of external fault input.
Non Operation	<ul style="list-style-type: none"> <li>● Transmission between the inverter and digital operator cannot be established 5 seconds after supplying power.</li> <li>● Transmission between the inverter and digital operator is established once after supplying power, but later transmission fault continued for more than 2 seconds.</li> </ul>	<ul style="list-style-type: none"> <li>● Insert the operator connector again.</li> <li>● Check the wiring of control circuit.</li> <li>● Replace the control board or operator.</li> </ul>

Protection function		Explanation	LCD display (English)
External baseblock signal input (Minor failure) ( main circuit transistor instantance shut-off )		When an external base block signal is input, the motor coasts to a stop. When the external base block signal is removed, the inverter output is immediately turned on at the previously set frequency.	(blinking) Alarm (bb)* <sup>1</sup> B.B.
Invalid parameter setting		When an invalid parameter is set, it is indicated on the monitor at power up or when the inverter is changed from the PRGM mode to the DRIVE mode.	Alarm (OPE01)* <sup>1</sup> Set Cap. Error
			Alarm (OPE02)* <sup>1</sup> Parameter Incorrect
			Alarm (OPE03)* <sup>1</sup> I/P Term. Incorrect
			Alarm (OPE10)* <sup>1</sup> V/F curve Incorrect
			Alarm (OPE11)* <sup>1</sup> Carry-Freq Incorrect
Parameter read error		Parameter read error	Alarm (Err)* <sup>1</sup> Read Error
RS-485 Communication Fault	Fault 1	RS-485 Communication error or transmission fault during communicating and the RS-485 stopping method after communication error of Sn-08 is to continue to run (Sn-08=11xx)	(blinking) (CPF21)* <sup>1</sup> Comm Fault 1
	Fault 2	RS-485 Communication protocol error and the RS-485 stopping method after communication error of Sn-08 is to continue to run (Sn-08=11xx)	(blinking) (CPF22)* <sup>1</sup> Comm Fault 2
RS-485 Communication Ready		When the inverter with communication option card (PA-M, PA-P, PA-C or PA-L) does not receive correct data from master controller.	(CALL)* <sup>1</sup> Comm Stand by

Fault Contact output	Error causes	Action to be taken
Non Operation	-	-
Non Operation	<ul style="list-style-type: none"> <li>● Inverter KVA setting (Sn-01) error</li> </ul>	<ul style="list-style-type: none"> <li>● Review the parameter setting range and conditions</li> </ul>
	<ul style="list-style-type: none"> <li>● Parameter setting range error</li> </ul>	
	<ul style="list-style-type: none"> <li>● Multi-function contact input setting error (Sn-15 ~ Sn-18)</li> </ul>	
	<ul style="list-style-type: none"> <li>● Improper setting of V/F characteristic (Cn-02 ~ Cn-08)</li> </ul>	
	<ul style="list-style-type: none"> <li>● Improper setting of carrier frequency (Cn-23 ~ Cn-25)</li> </ul>	
Non Operation	<ul style="list-style-type: none"> <li>● EEPROM internal data did not match when initializing the constant</li> </ul>	<ul style="list-style-type: none"> <li>● Turn off power, then turn on again. If error is persistent, replace the control board.</li> </ul>
Non Operation	<ul style="list-style-type: none"> <li>● RS-485 communication option card fault.</li> <li>● Excess vibration or shock.</li> <li>● External noise</li> </ul>	<ul style="list-style-type: none"> <li>● Turn off power, then turn on again. If error is persistent, replace the option card.</li> </ul>
Non Operation	<ul style="list-style-type: none"> <li>● The RS-485 communication protocols setting in inverter (Sn-24) and option card are inconsistent.</li> </ul>	<ul style="list-style-type: none"> <li>● Check the setting in Sn-24 and option card.</li> </ul>
Non Operation	<ul style="list-style-type: none"> <li>● Poor connection</li> <li>● Defective communication software (in master controller)</li> </ul>	<ul style="list-style-type: none"> <li>● Check for communication cable between communication option card and master controller (PLC)</li> <li>● Check for communication software.</li> </ul>

# APPENDIX

## A. ENERGY-SAVING CONTROL

### a. Constants related to Energy-saving Mode

The table below shows the constants used in the energy-saving mode.

**Constants used in Energy-saving Drive Mode**

Function	Parameter NO	Name and description	LCD Display (English)	Unit	Setting Range	Factory Setting
Operation Mode Select	Sn-09	-0- -: Energy Saving function ineffective (V/F) -1- -: Energy Saving function effective	Sn-09=0000 Term. A01 & Eng. Saving	-	-	0000
Energy-Saving Voltage Limit	Cn-45	Energy Saving Voltage upper limit (60Hz)	Cn-45=120% Hi_spd. Sav. V_Upper	1%	0 120%	120%
	Cn-46	Energy Saving Voltage upper limit (6Hz)	Cn-46=16% Lo_spd. Sav. V_Upper	1%	0 25%	16%
	Cn-47	Energy Saving Voltage lower limit (60Hz)	Cn-47=050% Hi_spd. Sav. V_Lower	1%	0 100%	50%
	Cn-48	Energy Saving Voltage lower limit (6Hz)	Cn-48=12% Lo_spd. Sav. V_Lower	1%	0 25%	12%
Energy-saving tuning operation	Cn-49	Tuning operation voltage limit	Cn-49=00% Sav. Tuning	1%	0 20%	0%
	Cn-50	Tuning operation control cycle	Cn-50=01.0s Sav. Tuning period	0.1s	0.1 10.0s	1.0s
	Cn-51	Tuning operation voltage step (100% output voltage)	Cn-51=00.5% Sav. Tuning Gain 1	0.1%	0.1 10.0%	0.5%
	Cn-52	Tuning operation voltage step (5% output voltage)	Cn-52=00.2% Sav. Tuning Gain 2	0.1%	0.1 10.0%	0.2%
Energy-saving coefficient K2	Cn-58	Energy-saving coefficient K2 (60Hz)	Cn-58=115.74* <sup>1</sup> Eng. Saving coeff.	0.01	0.00 655.35	115.74* <sup>1</sup>
	Cn-59	Energy-saving coefficient reduction ratio (6Hz)	Cn-59=100% K2 Reduce Ratio	1%	50 100%	100%
	Cn-60	Motor code	Cn-60=29* <sup>2</sup> Motor Select	-	00 FF	29* <sup>2</sup>
* <sup>3</sup> Energy-saving power detection	On-15	Power detection filter changing width	On-15=10% Power-Det. Dead Zone	1%	0 100%	10%
	On-16	Power detection filter time constant	On-16=20 Power-Det. Time Control	1 (7ms)	1 255	20 (140ms)

\* 1. Differences depending on the setting of Cn-60.

\* 2. The same value as Sn-01 is set by initializing.

\* 3. To change any of the On-□□ parameters, it is necessary to set Sn-03 to 1010.

Please set Sn-03 to 0000 after the On-□□ parameters changed.

### b. Energy-Saving operation procedures

- (1) Enter the energy-saving mode by setting the third digit of operation mode selection 5 (Sn-09) to 1. (The energy-saving mode is already set at prior to shipping.)
- (2) Set Cn-60 to the motor code (refer to page App-1) which is determined by the motor capacity and voltage.
- (3) Set operation frequency.
- (4) Input the run command  
The motor accelerates up to the set frequency (bn-01), when it reaches to the set value, the energy-saving mode is entered and operation is performed at voltage according to the load.

### c. Verification of Energy-saving Power

Energy-saving power can be verified by comparing power in the V/f control mode operation (Sn-09 third digit to 0) with power in the energy-saving mode operation (Sn-08 third digit to 1). Power can be monitored by Un-06.

Energy saved value varies according to the load ratio. Little energy-saving effect is obtained with the load ratio exceeding 70%. As the load becomes lighter, the effect becomes larger.

### d. Adjustment

Since the constants used in the energy-saving mode are already set to the optimum values as initial values, adjustment is not needed in the normal status. However, when the motor characteristics are much different from those of the TECO standard motors or if a fault occurs because of improper constant setting, perform the following, adjustment.

### Adjustment at fault Occurrence

Fault	Corrective Action
Power does not change in the energy-saving mode.	Does setting frequency exceed 100Hz? If it does, the energy-saving mode is released.
Power variation is very small in the energy-saving mode.	Is the load ratio excessively large? When the load ratio is excessively large, energy saved value becomes larger as the load becomes lighter.
Hunting at a light load	Increase the time constant (On-16) of power detecting filter.
Current increases to cause OL1 or OL2 although within rated load torque (Especially at low frequency).	Decrease the value (Cn-46) of energy-saving voltage upper limit at 6Hz. Or decrease the energy-saving coefficient reduction ratio (Cn-59).
When the energy-saving mode is entered after completion of acceleration, the motor stalls to a stop (Especially at a light load).	Increase the lower (Cn-47 or Cn-48).
Revolutions change periodically and its cycle is almost equal to Cn-50 set value.	Decrease search operation voltage stop (Cn-51 or Cn-52)

## B. PID CONTROL

### a. Constants related to PID Control Mode

The table below shows the constants used in the PID control mode.

#### Constants used in PID control Mode

Function	Parameter NO	Name and description	LCD Display (English)	Unit	Setting Range	Factory Setting
Setting of PID Control aimed value (Note 1)	An-01	Setting of aimed value 1 (Frequency command 1)	An-01 = 060.00Hz Frequency command 1	0.01Hz	0.00~180.00Hz	60.00Hz
	An-02	Setting of aimed value 2 (Frequency command 2)	An-02 = 000.00Hz Frequency command 2	0.01Hz	0.00~180.00Hz	0.00Hz
	An-03	Setting of aimed value 3 (Frequency command 3)	An-03 = 000.00Hz Frequency command 3	0.01Hz	0.00~180.00Hz	0.00Hz
	An-04	Setting of aimed value 4 (Frequency command 4)	An-04 = 000.00Hz Frequency command 4	0.01Hz	0.00~180.00Hz	0.00Hz
	An-05	Setting of aimed value 5 (Frequency command 5)	An-05 = 000.00Hz Frequency command 5	0.01Hz	0.00~180.00Hz	0.00Hz
	An-06	Setting of aimed value 6 (Frequency command 6)	An-06 = 000.00Hz Frequency command 6	0.01Hz	0.00~180.00Hz	0.00Hz
	An-07	Setting of aimed value 7 (Frequency command 7)	An-07 = 000.00Hz Frequency command 7	0.01Hz	0.00~180.00Hz	0.00Hz
	An-08	Setting of aimed value 8 (Frequency command 8)	An-08 = 000.00Hz Frequency command 8	0.01Hz	0.00~180.00Hz	0.00Hz
	An-09	Setting of aimed value 9 (Frequency command 9)	An-09 = 006.00Hz Jog command	0.01Hz	0.00~180.00Hz	6.00Hz
Setting of PID Control Constant	Bn-13	Setting of detected value adjustment (PID Detection Gain)	Bn-13 = 01.00 PID Gain	0.01	0.01~10.00	1.00
	Bn-14	Setting of proportional Gain (P)	Bn-14 = 01.0 PID P-Gain	0.1	0.0~10.0	1.0
	Bn-15	Setting of integral time (I)	Bn-15 = 010.0S PID I-Time	0.1S	0.0~100.0S	10.0S
	Bn-16	Setting of differential time (D)	Bn-16 = 0.00S PID D-Time	0.01S	0.00~1.00S	0.00S
	Bn-17	PID offset adjustment (PID Bias)	Bn-17 = 000% PID Bias	1%	0~109%	0%
	Cn-43	PID integral upper Bound	Cn-43 = 100% PID I-Upper	1%	0~109%	100%
	Cn-44	PID primary delay time constant	Cn-44 = 0.0S PID Filter	0.1S	0.0~2.5S	0.0S
Integral value reset	Sn-15 Sn-18	Integral value reset by external contact signal	-	-	-	-
PID Control Cancel	Sn-15 Sn-18	PID Control Canceled by external contact signal	-	-	-	-
PID Control selection	Sn-19	PID Control mode is entered by setting Sn-19=09	-	-	-	-
Control status 4	On-04	Selection of PID Control Mode	On-04=0000 Control status 4	1	0000~1111	0000

(Note 1) The unit and setting range of An- can be changed according to the setting of the operator display mode (Cn-20) as shown in the table above.

### b. How to input PID control signals

For setting of aimed values, the multi-function analog input (control terminal AUX) or Constant An-01 ~ 04 can be selected. The detected feedback value can be input from control terminal VIN (0 ~ 10V voltage signal) or Control terminal AIN. (4 ~ 20mA current signal), as shown below.

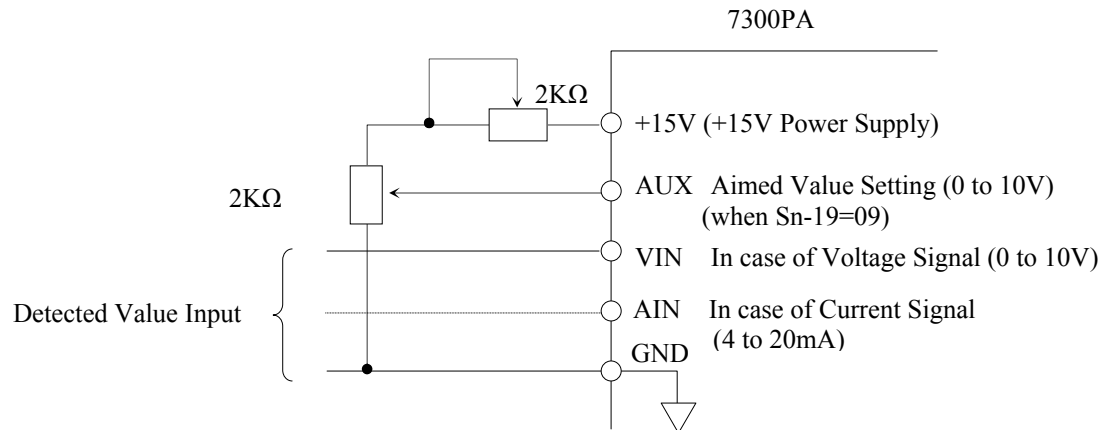

- (1) When only control terminal AUX is used: set Sn-04 = XXX0.
- (2) When constant An for frequency reference is used:  
Set the aimed values to An-01 to 08 and 09 The aimed value to be used can be selected by combination of multi-step speed reference 1, 2, 3 and jog command (setting by constant Sn-15 ~ 18), as the table below shown.

#### Selection of Aimed Values

Jog Command	Multi-step Speed 3	Multi-step Speed 2	Multi-step Speed 1	Value to be Selected
OFF	OFF	OFF	OFF	An-01
OFF	OFF	OFF	ON	An-02
OFF	OFF	ON	OFF	An-03
OFF	OFF	ON	ON	An-04
OFF	ON	OFF	OFF	An-05
OFF	ON	OFF	ON	An-06
OFF	ON	ON	OFF	An-07
OFF	ON	ON	ON	An-08
ON	-	-	-	An-09

\* When Sn-04 = XXX0 is set, AUX terminal signal is used instead of An-01. An-01 is used when Sn-04 = XXX1.

c. How to adjust

The PID control function is a control system that matches a feedback value (ie., a detected value) to the aimed value. Combining P (Proportional, Bn-14), I (Integral, Bn-15), and D (Derivated, Bn-16) makes control possible even for a mechanical system with dead time. The PID control function, using different detected sensors, can be used for speed, pressure, flow or temperature etc. applications.

(1) PID control operations.

In order to distinguish the separate PID control operations. The figure below shown the changes in the control input when the deviation between the target value and the feed back is held constant.

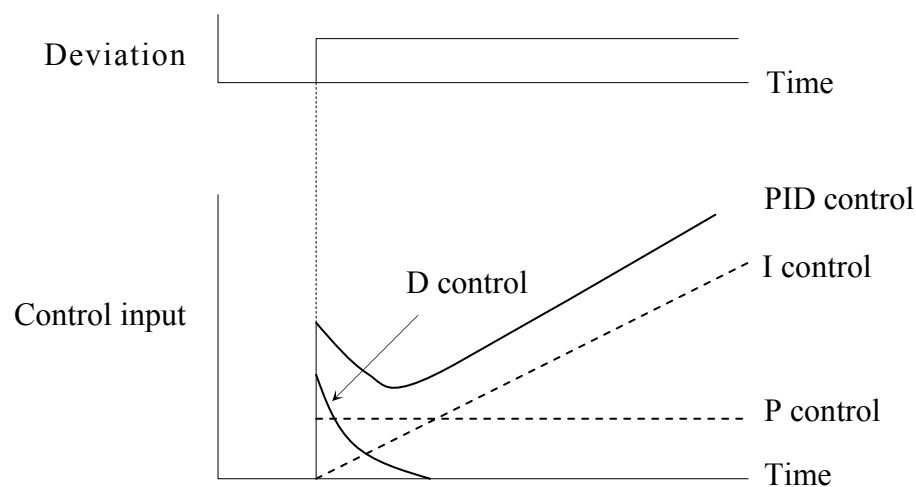

**Fig. 14 PID Control Operations**

- P Control: A control input proportional to the deviation is output. The deviation cannot be zeroed by P control alone.
- I Control: A control input which is an integral of the deviation is output. This is effective for matching the feedback to the target value. Sudden changes, however, cannot be followed.
- D Control: A control input which is an integral of the deviation is output. Quick response to sudded changes is possible.
- PID Control: Optimum control is achieved by combining the best features of P, I, and D control.

## (2) Adjusting PID constant

Refer to page, the block diagram of PID control selection, using the following procedure to activate PID control and then adjust it while monitoring the response.

- ( I ) Enable PID control function (Setting Sn-19 = 09, and if any constant Sn-15 ~ 18 setting value is 66, then none of control terminal 5 ~ 8 can be closed).
- ( II ) Increase the proportional gain P (Bn-14) as far as possible without creating oscillation.
- ( III ) Reduce in integral time I (Bn-15) as far as possible without creating oscillation.
- ( IV ) Increase the differential time D (Bn-16) as far as possible without creating oscillation.

First set the individual PID control constants, and then make fine adjustments.

- Reducing Overshooting

If overshooting occurs, shorten the derivative time D (Bn-16) and lengthen the integral time I (Bn-15)

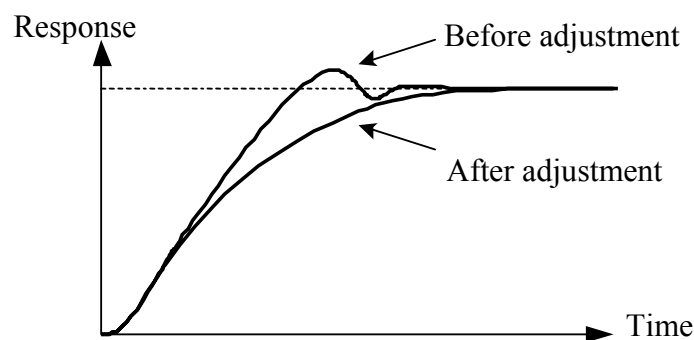

- Rapidly Stabilizing Control Status

To rapidly stabilize the control conditions even when overshooting occurs, shorten the integral time I (Bn-15) and lengthen the derivative time D (Bn-16)

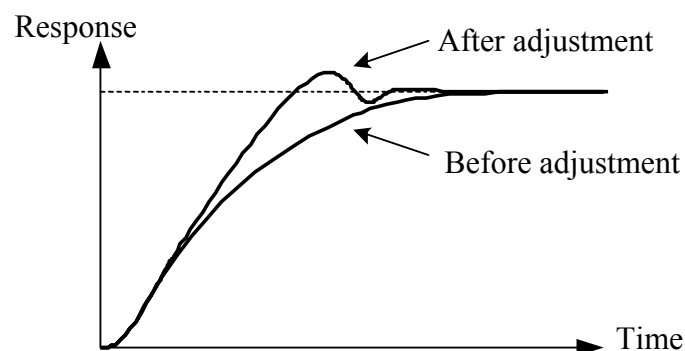

- Reducing Long-cycle Oscillation

If oscillation occurs with a longer cycle than the integral time  $I$  (Bn-15) setting it means that integral operation is strong. The oscillation will be reduced as the integral time  $I$  is lengthened.

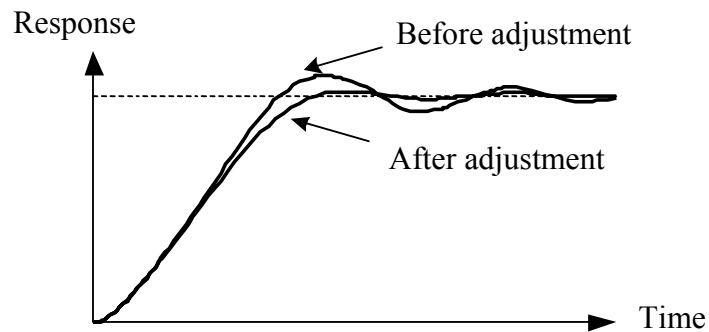

- Reducing Short-cycle Oscillation

If the oscillation cycle is short and oscillation occurs with a cycle approximately the same as the derivative time  $D$  (Bn-16) setting, it means that the derivative operation is strong. The oscillation will be reduced as the derivative time ( $D$ ) is shortened.

If oscillation cannot be reduced even by setting the derivative time ( $D$ ) to "0.00" (no derivative control), then either lower the proportional gain  $P$  (Bn-14) or raise the PID's primary delay time constant (Cn-44).

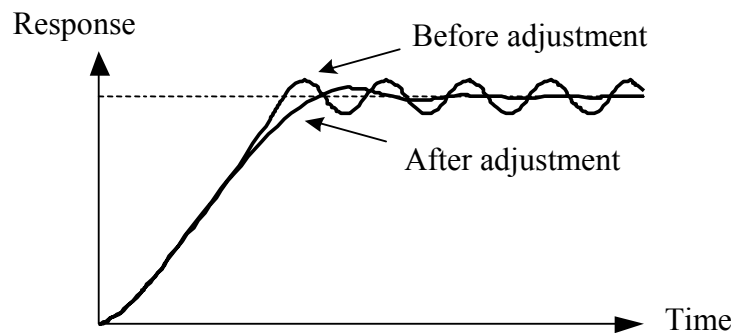

## C. RS-485 COMMUNICATION CONNECTION DIAGRAM

7300PA provide PA-M (MODBUS protocol) and PA-P (PROFIBUS-DP protocol) option card for RS-485 communication interface. The wiring diagrams of PA-M and PA-P are as below.

### (a) PA-M MODBUS protocol communication

The PA-M option card supports the MODBUS protocol can be placed at the upper side of the control board.

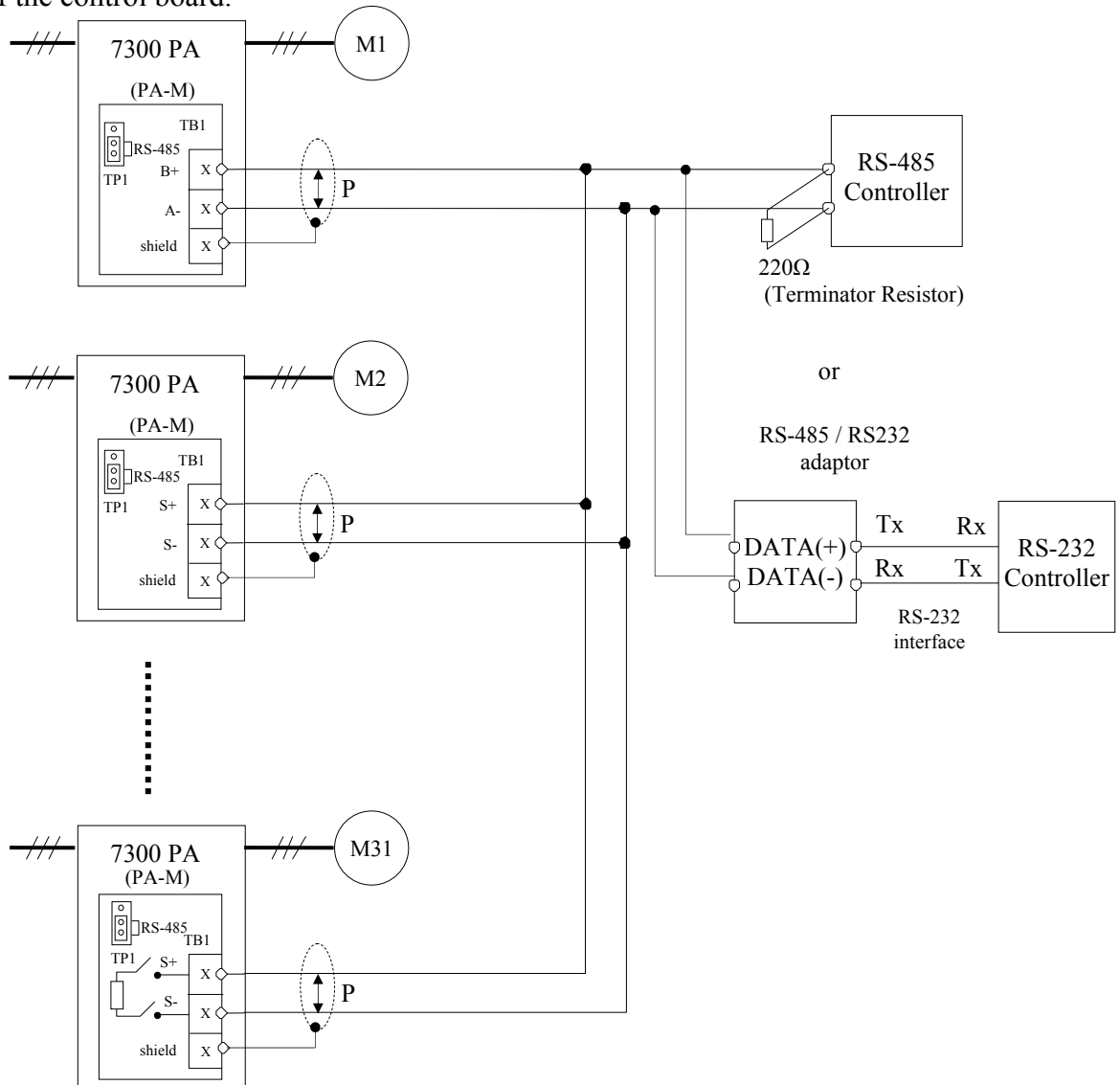

**Fig. 15 Wiring for PA-M MODBUS Protocol communication**

Note : 1. A Host Controller with RS-485 interface can communicate with the 7300PA unit through PA-M option card. If the Host Controller does not provide the RS-485 port and its RS-232 port is available, an RS-485/RS-232 conversion card should be used to connect between this Host Controller and PA-M option card of 7300PA.

2. A MODBUS Host Controller can drive the network with no more than 31 drivers connected, using MODBUS communication standard. If the driver (e.g., 7300PA drive) is at the end of the network it must have the terminating resistors  $220\Omega$  at both terminals (By SW1 dip Switch). All other drives in the system should not have terminators.
3. The PA-M card with RS-485 and RS-422 interface can be selected by TP1 jumper.
4. Please refer to "7300PA PA-M RS-485 MODBUS Communication Application Manual".

## (b) PA-P PROFIBUS protocol communication

The PA-P PROFIBUS option supports the PROFIBUS protocol. The PA-P option card can be mounted at the control board directly.

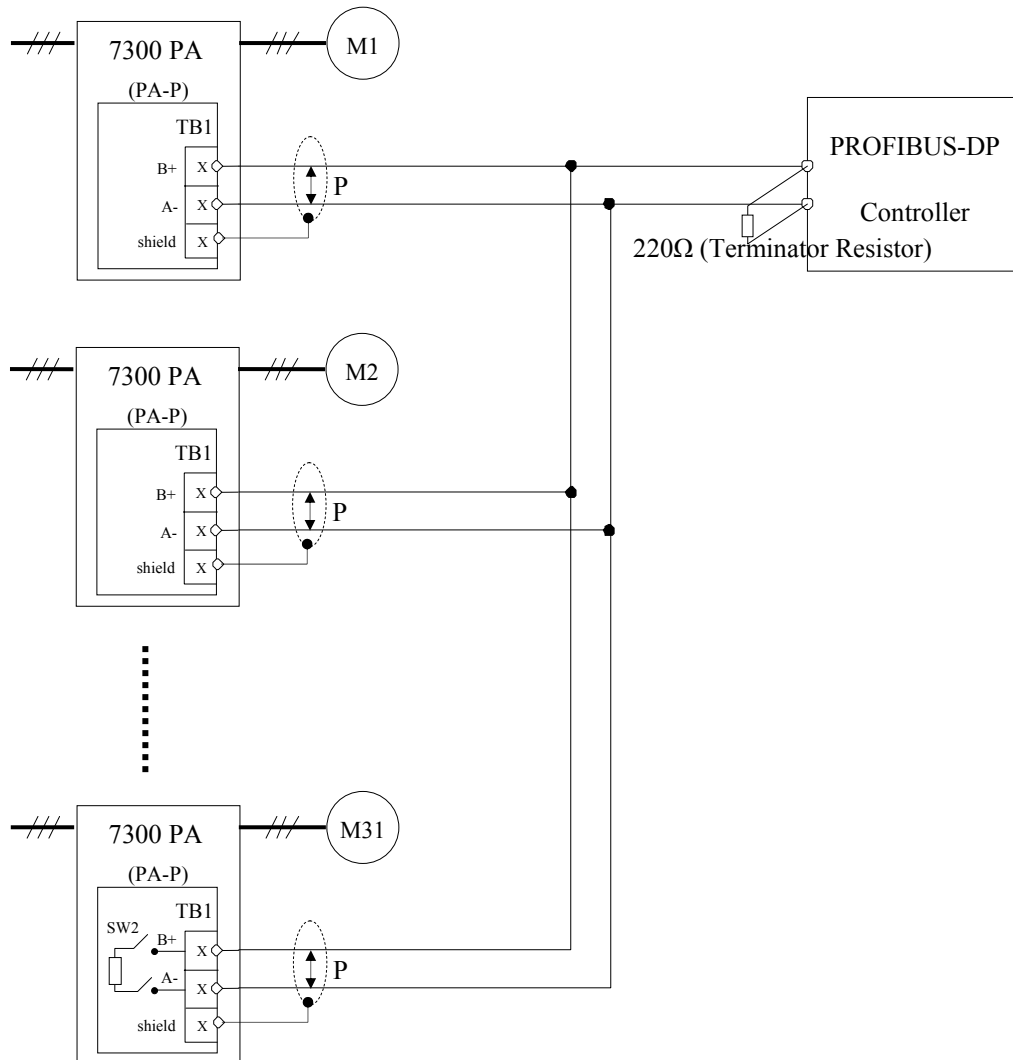

**Fig. 16 Wiring for PROFIBUS protocol communication**

- Note : 1. A maximum of 31 PROFIBUS-DP stations (nodes) may be contained within a single network segment. If the drive is at the end of the network it must have 220Ω between terminals B<sup>+</sup> and A<sup>-</sup> of PA-P card by SW2 dip switch.
2. For more details, please refer to the manual "7300PA PA-P PROFIBUS-DP Communication Application manual".

## D. SINK/SOURCE TYPICAL CONNECTION DIAGRAM

- The terminal 1 ~ 8 can be connected as SINK or SOURCE type input interface by different connection of terminal 24VG, SC and 24V.

### a. SINK MODE

1 Internal power supply (Sinking Mode)

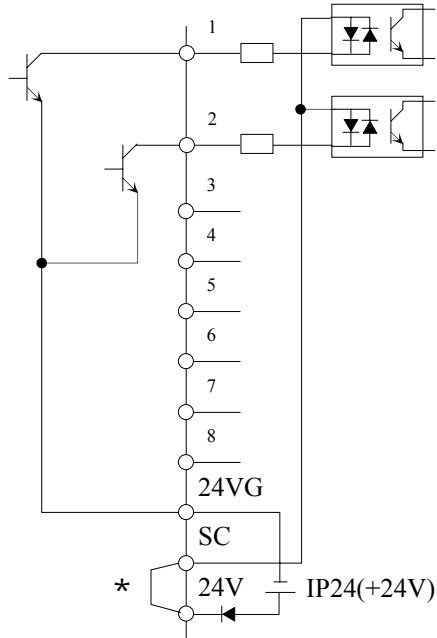

2 External power supply (Sinking Mode)

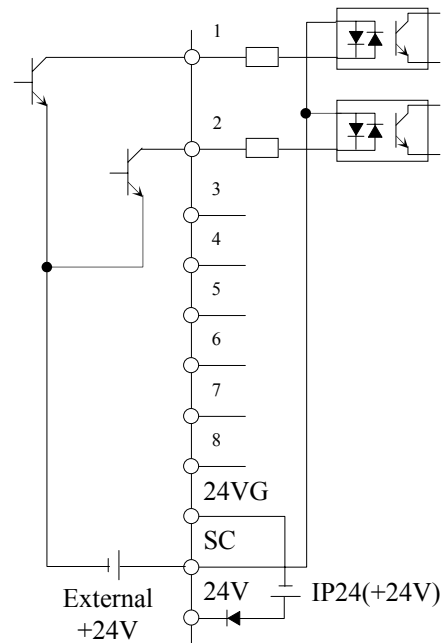

\* shorted at factory setting

< Note 1 > Contact signal used for operation signal

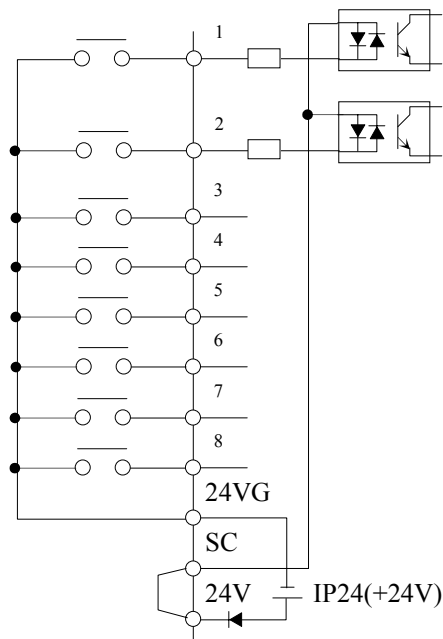

< Note 2 > NPN sensor (Sink) used for operation signal

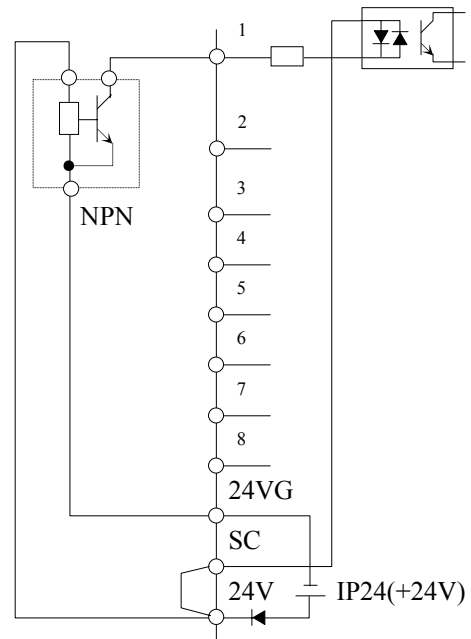



## E. RS-232C SERIAL COMMUNICATIONS CONNECTION DIAGRAM

The Digital operator uses RS-232C serial communication through connector CN1 to communicate with control board. Using the CN1 port on the control board, parameters can be monitored and updated by a suitable PC programming tool.

The CN1 port is an un-isolated RS-232C with baud rate 2400 bps. Contact TECO for further information.

- The pin definitions of CN1
  - 6 pin telephone jack

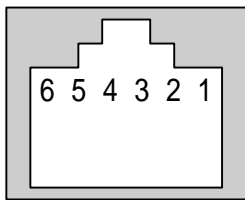

Pin	Signal Definition
1	LCD/PC selection
2	5V
3	Rx
4	Tx
5	0V
6	Reserved (negative voltage, for LCD display)

- Typical connection diagram

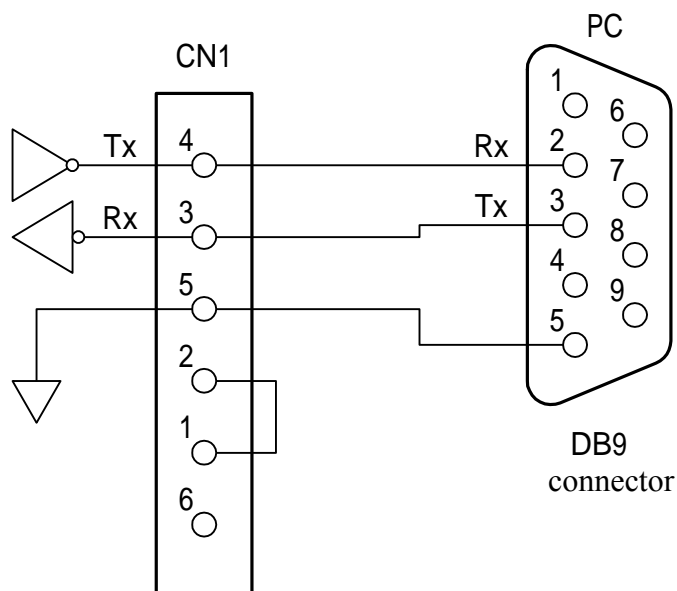

## F. NOTES ON APPLICATION OF MOTORS

### Motor Application Notes for Standard Motors

A standard motor driven by the inverter generates slightly less power than it does when it is driven with commercial power supply. Also, the cooling effect deteriorates in low speed range so that the motor temperature rise increases. Reduce load torque in the low speed range. Allowable load characteristics of the standard motor are shown in the figure. If 100% continuous torque is required in the low speed range, use an inverter duty motor.

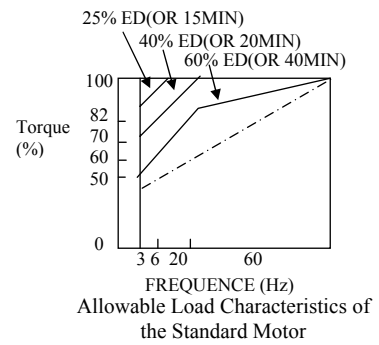

#### High speed operation

When the motor is used above 60Hz, motor mechanical design should be verified. Contact your motor manufacturer.

#### Torque characteristics

Motor torque characteristics vary when the motor is driven by an inverter instead of commercial power supply. Check the load torque characteristics of the machine to be connected.

#### Vibrations

Because of the high carrier modulation technique for PWM control, the 7300PA series reduces motor vibration to a level equal to running with a commercial power supply. Larger vibrations may occur under the following conditions:

- (1) Response at resonant frequency of the mechanical system.  
Special care is required if a machine which has previously been driven at a constant speed, is to be driven at varying speeds. Installation of anti-vibration rubber padding under the motor base and frequency jump control are recommended.
- (2) Rotator residual imbalance  
Special care is required for operation at 60Hz or higher frequencies.

#### Noise

Inverter operation is as quiet as operation with commercial power supply. At above rated speed (60Hz), noise may increase by motor cooling fan.

### Application to Special Purpose Motors

Motors with Brakes	Use brake-equipped motors with an independent power supply. Connect the brake power supply to the inverter primary side. When the brake Operates (the motor stops) it turns the inverter output OFF. Some types of brakes may make abnormal sounds in low speed range.
Pole Change Motors	Select the inverter with a capacity exceeding the rated current of each pole. Pole change should be made only after the motor stops. If a pole is changed while the motor is rotating, the regenerative overvoltage or overcurrent protection circuit is activated and the motor coasts to a stop.
Submersible Motors	Since the rated current of underwater motors is large compared with general purpose motors, select an inverter with a larger capacity. If the wire length between the inverter and the motor is large, use cables with sufficiently large diameter.
Explosion-proof Motors	Explosion-proof motors which are applied to inverters must be currently approved as explosion-proof equipment. The inverter is not explosion-proof and should not be located where explosive gases exist.
Geared Motors	Lubrication method and continuous rotation limit differ with manufacturers. When oil lubrication is employed, continuous operation only in low speed range may cause burnout. Before operating the motor at more than 60Hz, you should consult the motor manufacturer.
Single-phase Motors	Single-phase motors are not suitable for variable speed operation with an inverter. If the inverter is applied to a motor using a capacitor stack, a high harmonic current flows and the capacitor may be damaged. For split-phase start motors and repulsion start motors, the internal centrifugal switch will not be actuated and the starting coil may be burned out. Therefore, only use 3-phase motors.

#### Power Transmission Mechanism (Gear Reduction, Belt, Chain, etc.)

When gear boxes and change/reduction gears lubricated with oil are used in power transmission systems, (Continuous low speed operation decreases the oil lubrication function). Also, operation at more than 60Hz may result in noise, reduced life, etc.

## G. PERIPHERAL UNIT NOTES

### Installation and selection of molded-case circuit breaker

On the input power side, a molded case circuit breaker (MCCB) to protect inverter primary wiring should be installed. The inverter power factor (depending on power voltage, output frequency, and load) must be taken into account for selecting the MCCB. For standard selection, see part page 4-5. If a full electromagnetic MCCB is to be used, select a larger capacity because the operating characteristics are altered by harmonic current. A leakage current breaker of inverter use is recommended.

### Use of input side magnetic contactor

The inverter can be used without an input side magnetic contactor (MC). An input MC can be used to prevent an automatic restart after recovery from an external power loss during remote control operation. However, do not use the MC frequently for start/stop operation, or it will lead to a reduced reliability. When the digital operator is used, automatic restart after power failure is disabled so that MC starting is impossible. Although the MC can stop the inverter, regeneration braking is disabled and the motor coasts to stop.

### Use of secondary magnetic contactor

In general, magnetic contactors on the output of the inverter for motor control should not be used. Starting a motor with the inverter running will cause large surge currents and the inverter overcurrent protector to be triggered. If an MC is used for switching to commercial power supply, switch MC after the inverter and the motor stop. To switch during motor rotation, use the speed search function.

### Use of overload relay

The inverter includes an electronic thermal protective function to protect the motor from overheating. If more than one motor is driven with a single inverter or when a multi-pole motor is used, place an overload relay between the inverter and the motor. Set 1 to the first position of Sn-14 (xxx1), and set the overload relay to the current nameplate value at 50Hz, or 1.1 times of that at 60 Hz.

### Power-factor improvement (elimination of phase advance capacitor)

To improve the power-factor, install an AC reactor on the inverter's primary side. Power-factor improvement capacitors or surge suppressors on the inverter output side will be damaged by the harmonic component in the inverter output. Also, the over current caused in the inverter output will trigger the over current protection. To avoid this, do not use capacitors or surge suppressors in the inverter's output. To improve the power-factor, install an AC reactor on the inverter primary side.

### Radio frequency interference

Because the inverter I/O (main circuit) contains a higher harmonics component, it may emit RFI noise to communication equipment (AM radio, etc.) near the inverter. Use a noise filter to decrease the noise. Use of a metallic conduit between the inverter and motor and grounding the conduit is also effective. Proper routing of input and output leads is also recommended.

### Wire thickness and cable length

If the inverter is connected to a distant motor, (especially when low frequency is output,) motor torque decreases because of voltage drop in the cable. Use sufficiently heavy wire.

When a digital operator is to be installed separately from the inverter, use the TECO connection cable (option). For remote control with analog signals, connect the operating pot or operating signal terminal and the inverter within 30m of the inverter. The cable must be routed separately from power circuits (main circuit and relay sequence circuit) so that it is not subjected to inductive interference by other equipment. If frequencies are set not only from the digital operator but also with external frequency controller, use twisted pair shielded wire as shown in the following figure and connect the shielding to terminal E, not to the ground.

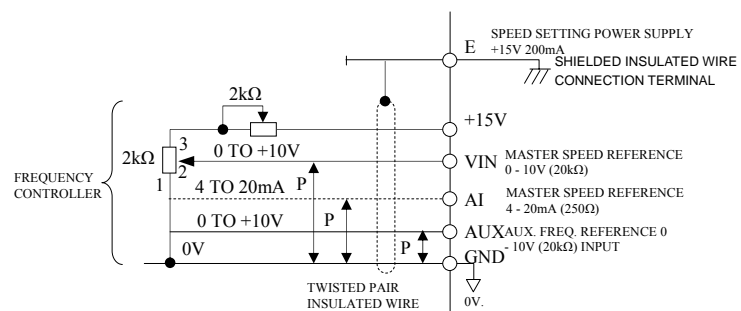

## H. CIRCUIT PROTECTION AND ENVIRONMENTAL RATINGS NOTES

### Circuit Protection

The maximum rms symmetrical amperes and voltage of 7300PA series are to listed as follows

Device Rating		Short circuit Rating (A)	Maximum Voltage (V)
Voltage	HP		
220V	1.5 ~ 50	5,000	240V
	51 ~ 100	10,000	
440V	1.5 ~ 50	5,000	480V
	51 ~ 200	10,000	
	201 ~ 500	18,000	
575V	1.5 ~ 60	5,000	600V
	75 ~ 100	10,000	

### Environmental Ratings

The 7300PA is suitable for use in pollution degree 2 environments.

### Field Wiring Terminals and Tightening Torque

The wiring terminals and tightening torque as follows.

(The main circuit terminal specifications – use 60/75°C copper wire only)

#### (a) 220V class

Circuit	Inverter Rating (HP)	Terminals Mark	Cable Size (AWG)	Terminals	Tightening Torque (pound-in.)
Main Circuit	5~10	⊕, L1, L2, L3, T1, T2, T3, B2, R, P, ⊖	8	M4	15.6
		-	-	-	-
	15~25	L1, L2, L3, T1, T2, T3, B2, P, ⊖	4	M5	30
		⊕	6	M6	35
	30	L1, L2, L3, T1, T2, T3, ⊕, ⊖	4	M8	78
		⊕	6	M10	156
	40	L1, L2, L3, T1, T2, T3, ⊕, ⊖	2/0	M8	78
		⊕	4	M10	156
	50	L1, L2, L3, T1, T2, T3, ⊕, ⊖	2/0	M8	78
		⊕	4	M10	156
	60	L1, L2, L3, T1, T2, T3, ⊕, ⊖	2/0 x 2P	M8	78
		⊕	4	M10	156
	75	L1, L2, L3, T1, T2, T3, ⊕, ⊖	2/0 x 2P	M8	78
		⊕	2	M10	156
100, 125	L1, L2, L3, T1, T2, T3, ⊕, ⊖	4/0 x 2P	M10	156	
	⊕	1/0	M10	156	
Control Circuit	All series	1 ~ 33	24 - 14	M3	5

## (b) 440V class

Circuit	Inverter Rating (HP)	Terminals Mark	Cable Size (AWG)	Terminals	Tightening Torque (pound-inchs)
Main Circuit	5~10	⊕, L1, L2, L3, T1, T2, T3, B2, R, P, ⊖	10	M4	15.6
		-	-	-	-
	25	L1, L2, L3, T1, T2, T3, B2, ⊕, ⊖	8	M4	15
		⊕	8	M6	35
	30	L1, L2, L3, T1, T2, T3, B2, ⊕, ⊖	8	M4	15
		⊕	8	M6	35
	40	L1, L2, L3, T1, T2, T3, ⊕, ⊖	6	M6	35
		⊕	8	M10	156
	50	L1, L2, L3, T1, T2, T3, ⊕, ⊖	4	M6	35
		⊕	6	M10	156
	60	L1, L2, L3, T1, T2, T3, ⊕, ⊖	4	M8	78
		⊕	6	M10	156
	75	L1, L2, L3, T1, T2, T3, ⊕, ⊖	1	M8	78
		⊕	4	M10	156
	100	L1, L2, L3, T1, T2, T3, ⊕, ⊖	2/0	M8	78
		⊕	4	M10	156
	125	L1, L2, L3, T1, T2, T3, ⊕, ⊖	2/0 x 2P	M10	156
		⊕	4	M10	156
	150	L1, L2, L3, T1, T2, T3, ⊕, ⊖	2/0 x 2P	M10	156
		⊕	2	M10	156
175	L1, L2, L3, T1, T2, T3, ⊕, ⊖	2/0 x 2P	M10	156	
	⊕	2	M10	156	
215	L1, L2, L3, T1, T2, T3, ⊕, ⊖	4/0 x 2P	M10	156	
	⊕	1/0	M10	156	
250	L1, L2, L3, T1, T2, T3, ⊕, ⊖	4/0 x 2P	M10	156	
	⊕	1/0	M10	156	
300	L1, L2, L3, T1, T2, T3, ⊕, ⊖	4/0x 2P	M10	156	
	⊕	2/0	M10	156	
350, 400	L1, L2, L3, T1, T2, T3, ⊕, ⊖	650 x 2P	M12	277	
	⊕	2/0	M10	156	
400, 500	L1, L2, L3, T1, T2, T3, ⊕, ⊖	650 x 2P	M12	277	
	⊕	2/0	M10	156	
Control Circuit	All series	1 ~ 33	20 - 14	M3	5

## (C) 575V class

Circuit	Inverter Rating (HP)	Terminals Mark	Cable Size (AWG)	Terminals	Tightening Torque (pound-in.)	
Main Circuit	5~10	⊕, L1, L2, L3, T1, T2, T3, B2, ⊕, ⊖	8	M4	15.6	
		-	-	-	-	
	15~25	L1, L2, L3, T1, T2, T3, B2, ⊕, ⊖	4	M6	35	
		⊕	6	M6	35	
	30	L1, L2, L3, T1, T2, T3, ⊕, ⊖	4	M6	35	
		⊕	6	M10	156	
	40	L1, L2, L3, T1, T2, T3, ⊕, ⊖	4	M6	35	
		⊕	6	M10	156	
	50	L1, L2, L3, T1, T2, T3, ⊕, ⊖	2/0	M6	35	
		⊕	4	M10	156	
	60	L1, L2, L3, T1, T2, T3, ⊕, ⊖	2/0	M6	35	
		⊕	4	M10	156	
	75	L1, L2, L3, T1, T2, T3, ⊕, ⊖	2/0 x 2P	M8	78	
		⊕	2	M10	156	
	100	L1, L2, L3, T1, T2, T3, ⊕, ⊖	2/0 x 2P	M8	78	
		⊕	2	M10	156	
	Control Circuit	All series	1 ~ 33	24 - 14	M3	5

**I. INVERTER HEAT LOSS****● 220V CLASS**

Inverter (HP)	5	7.5	10	15	20	25	30	40	50	60	75	100	125
Inverter Capacity (KVA)	6.2	9.3	12.4	18.6	24.8	27.4	33	44	55	63	81	110	125
Rated Output Current (A)	16	24	32	48	64	72	88	117	144	167	212	288	327
Switching Frequency (KHz)	10	10	10	10	10	6	6	6	6	3	3	3	3
Fin Cooling	Fan cooled												
Total Power Loss (W)	125	182	238	350	470	681	705	944	1086	1468	1924	2151	2452

**● 440V CLASS**

Inverter (HP)	5	7.5	10	15	20	25	30	40	50	60	75
Inverter Capacity (KVA)	6.2	9.3	12.4	18.6	24.8	29	34	45	57	66	85
Rated Output Current (A)	8	12	16	25	32	38	44	59	75	86	111
Switching Frequency (KHz)	10	10	10	10	10	6	6	6	6	6	6
Fin Cooling	-	Fan cooled									
Total Power Loss (W)	101	178	198	343	387	573	676	764	1010	1088	1254

Inverter (HP)	100	125	150	175	215	250	300	350	400	500
Inverter Capacity (KVA)	115	144	176	203	232	259	290	393	446	558
Rated Output Current (A)	151	189	231	267	304	340	380	516	585	732
Switching Frequency (KHz)	3	3	3	3	3	3	2	2	2	2
Fin Cooling	Fan cooled									
Total Power Loss (W)	1507	1882	2240	2614	3016	3487	3500	6205	7270	8808

**● 575V CLASS**

Inverter (HP)	5	7.5	10	15	20	25	30	40	50	60	75	100
Inverter Capacity (KVA)	6.0	8.9	10.9	16.9	22	27	32	41	52	62	77	99
Rated Output Current (A)	6.1	9.0	11	17	22	27	32	41	52	62	77	99
Switching Frequency (KHz)	10	10	10	10	10	10	10	10	10	10	10	4
Fin Cooling	Fan cooled											
Total Power Loss (W)	98	170	186	325	388	520	653	744	960	1043	1227	1490

## J. DRIVE INPUT FUSES

■ Drive input fuses are provided to disconnect the drive from power in the event that a component fails in the drive's power circuitry . The drive's electronic protection circuitry is designed to clear drive output short circuits and ground faults without blowing the drive input fuses . Below table shows the 7300PA input fuse ratings.

Inverter		Drive Input Fuse Ratings (Semiconductor protection)		
Voltage	HP	Rated Voltage	Amps	Fuse Type (FERRAZ)
220V	5	300VAC	35	A30QS35-4
	7.5		40	A30QS40-4
	10		50	A30QS50-4
	15		80	A30QS80-4
	20		100	A30QS100-4
	25		125	A30QS125-4
	30		150	A30QS150-4
	40		175	A30QS175-4
	50		250	A30QS250-4
	60		250	A30QS250-4
	75		350	A30QS350-4
	100		450	A30QS450-4
	125		500	A30QS500-4
440V	5	500VAC	15	-
	7.5		20	-
	10		35	A50QS35-4
	15		40	A50QS40-4
	20		50	A50QS50-4
	25		60	A50QS60-4
	30		70	A50QS70-4
	40		90	A50QS90-4
	50		125	A50QS125-4
	60		125	A50QS125-4
	75		175	A50QS175-4
	100		225	A50QS225-4
	125		300	A50QS300-4
	150		350	A50QS350-4
	175		400	A50QS400-4
	215		450	A50QS450-4
	250		500	A50QS500-4
	300		600	A50QS600-4
350	800	A50QS800-4		
400	900	A50QS900-4		
500	1200	A50QS1200-4		
575V	5	600VAC	15	A60X15-1
	7.5		20	A60X20-1
	10		39	A60X30-1
	15		40	A60X40-1
	20		60	A60X60-1
	25		60	A60X60-1
	30		70	A60X70-1
	40		100	A60X100-1
	50		125	A60X125-1
	60		150	A60X150-1
	75		200	A60X200-1
	100		250	A60X250-1

---

## K. CERTIFICATION FOR THE INVERTER

### ■ CE Mark

- The 7300PA drives conform to the European Union Electromagnetic Compatibility Directive, when installed according to the recommendations described in the “EMC Installation Guideline” manual.
- The tests were made in accordance with the following basic standards:
  - EN55011 (2000-05) : Conducted Emission and Radiated Emission.
  - EN61000-4-2 (1995-03) : ESD
  - EN61000-4-3 (1998 ) : RFI Immunity
  - EN61000-4-4 (1995-03) : Fast Transient (Burst)
  - EN61000-4-5 (1995-03) : Slow Transient (Surge)
  - EN61000-4-6 (1996-07) : RF Common Mode Immunity
  - EN61000-4-11(1994) : Voltage Dips, Short Interruptions and  
Voltage Variations Immunity

### ■ CSA Mark

- CSA Certificate Number : 219607
- Applicable Requirements :
  - C22.2 NO. 0-92 : General Requirements
  - CAN/CAS – C22.2 NO. 14-95 : Industrial Control Equipment–  
Industrial Products.
  - UL std. NO.508C : Power Conversion Equipment



**TECO Electric & Machinery Co., Ltd.**

10F, No.3-1, Yuancyu St., Nangang District,  
Taipei City 115, Taiwan  
Tel :+886-2-6615-9111  
Fax : +886-2-6615-0933

<http://www.teco.com.tw>

Distributor

Ver:07 2006.09

---

This manual may be modified when necessary because of improvement of the product, modification, or changes in specifications, This manual is subject to change without notice.